



Chipsmall Limited consists of a professional team with an average of over 10 year of expertise in the distribution of electronic components. Based in Hongkong, we have already established firm and mutual-benefit business relationships with customers from,Europe,America and south Asia,supplying obsolete and hard-to-find components to meet their specific needs.

With the principle of “Quality Parts,Customers Priority,Honest Operation,and Considerate Service”,our business mainly focus on the distribution of electronic components. Line cards we deal with include Microchip,ALPS,ROHM,Xilinx,Pulse,ON,Everlight and Freescale. Main products comprise IC,Modules,Potentiometer,IC Socket,Relay,Connector.Our parts cover such applications as commercial,industrial, and automotives areas.

We are looking forward to setting up business relationship with you and hope to provide you with the best service and solution. Let us make a better world for our industry!



## Contact us

Tel: +86-755-8981 8866 Fax: +86-755-8427 6832

Email & Skype: info@chipsmall.com Web: www.chipsmall.com

Address: A1208, Overseas Decoration Building, #122 Zhenhua RD., Futian, Shenzhen, China



4831, PCB terminals, screened, 2-pole, Audio Plug/Sockets, 2.5 mm



**Description**

- PCB Mounting :  
Screw-on mounting , from rear-side
- Audio entrances and exits
- Data and Signal transfer
- Audio Plug: 2-pole , shielded , straight

**References**

Alternative: Housing insulated [4831.2230](#)

**Technical Data**

Diameter	2.5 mm
Number of Poles	2-pole
Ratings DC	0.5 A / 30 VDC
Ratings AC	0.5 A / 30 VAC
Dielectric Strength	500VDC
Insulation Resistance	> 100 MΩ @ 500VDC

Allowable Operation Temperature	-20 °C to 70 °C
Terminal	PCB terminals silver plated
Mounting	Screw-on mounting wall thickness max. 1.5 mm
Housings	screened
Style	straight
Lifetime	5000 Insertions

Detailed information on product approvals, code requirements, usage instructions and detailed test conditions can be looked up in [General Product Information](#)

**Dimensions**

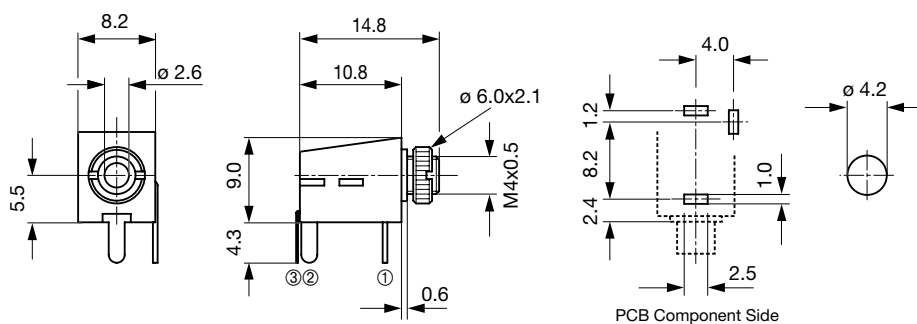

**Diagrams**

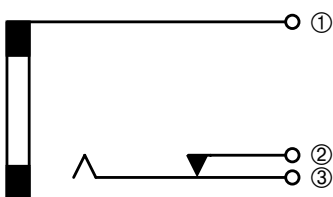

## All Variants

Product group	Diameter [mm]	Number of Poles	Terminal	Order Number
Audio Plug/Sockets	2.5	2-pole	PCB terminals	4831.2220

Availability for all products can be searched real-time:<http://www.schurter.com/en/Stock-Check/Stock-Check-SCHURTER>

---

**Packaging unit**      500 Pcs

---

## Mating Inlets/Plugs

### Category / Description

[Audio Plug/Sockets Overview complete](#)



4831, solder terminal, screened, 2-pole, Audio Plug/Sockets, 2.5 mm	4831.1200
4831, solder terminal, insulated, 2-pole, Audio Plug/Sockets, 2.5 mm	4831.1210
4831, solder terminal, insulated, 2-pole, Audio Plug/Sockets, 2.5 mm	4831.1220

[Audio Plug/Sockets further types to 4831.2220](#)

---