



Chipsmall Limited consists of a professional team with an average of over 10 year of expertise in the distribution of electronic components. Based in Hongkong, we have already established firm and mutual-benefit business relationships with customers from,Europe,America and south Asia,supplying obsolete and hard-to-find components to meet their specific needs.

With the principle of “Quality Parts,Customers Priority,Honest Operation,and Considerate Service”,our business mainly focus on the distribution of electronic components. Line cards we deal with include Microchip,ALPS,ROHM,Xilinx,Pulse,ON,Everlight and Freescale. Main products comprise IC,Modules,Potentiometer,IC Socket,Relay,Connector.Our parts cover such applications as commercial,industrial, and automotives areas.

We are looking forward to setting up business relationship with you and hope to provide you with the best service and solution. Let us make a better world for our industry!



Contact us

Tel: +86-755-8981 8866 Fax: +86-755-8427 6832

Email & Skype: info@chipsmall.com Web: www.chipsmall.com

Address: A1208, Overseas Decoration Building, #122 Zhenhua RD., Futian, Shenzhen, China



Port Powered RS-232 to RS-485 Converter

Model 485LP9R

CE



The 485LP9R is a port-powered two-channel RS-232 to RS-485 converter. It converts TD and RD RS-232 lines to balanced RS-485 signals. The unit can be powered from the RS-232 handshake lines, DTR and RTS.

One of these handshakes must be high (asserted) to power the unit (See Table 1). DTR must be asserted to receive data. The RS-485 driver is enabled when RTS is asserted and disabled when RTS is disasserted. The RS-485 receiver is disabled when the driver is enabled and is enabled when the driver is disabled.

In order to maximize the amount of power available to the RS-485 driver, the RS-232 **handshake lines are not looped back** (tied together). As a result the following handshake lines will appear as disasserted (low): CTS, DCD, and DSR. Care should be taken to insure that any software being used doesn't require any of these handshake lines be asserted. If existing software requires any of the handshake lines to be asserted, you can loop back the required handshake lines in your cable.

Table 1

RTS State	DTR State	Functions Possible (when port powering unit)
Low	Low	none
Low	High	Receive
High	Low	Transmit
High	High	Transmit

* NOTE: Low = disasserted and High = asserted

Connections

A typical two wire RS-485 connected is shown in Figure 1. Regardless of the system, the 485LP9R must be connected with the proper polarity. With no data is being sent and the driver enabled, the RS-232 line should be negative and the TD(A) should be negative with respect to TD(B).

Proper operation of any RS-485 system requires the presence of a signal return path between the signal grounds of the equipment at each end of an interconnection. This circuit reference may be established by a third conductor connecting the common leads of devices, or it may be provided by connections in each equipment to an earth reference. When the circuit reference is provided by a third conductor, the connection between the signal grounds and the third conductor should contain some resistance (e.g. 100 ohms) to limit circulating currents when other ground connections are provided for safety.

Figure 1

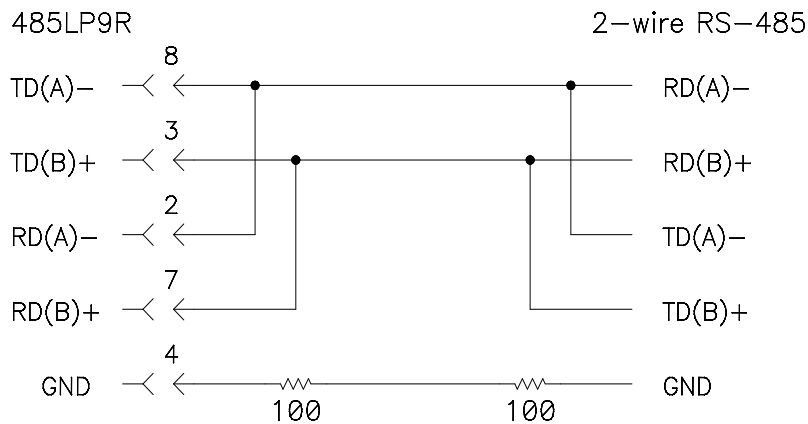

Table 2 - 485LP9R Pin Outs

Signal	DB-9S Pin #
Transmit Data A (-)	8
Transmit Data B (+)	3
Receive Data A (-)	2
Receive Data B (+)	7
Signal Ground	4, 6

Biasing Resistors

The biasing resistors for the RS-485 receiver are 4.7K Ohm resistors. These resistors are labeled R1 and R6 (See Figure 2). Refer to B&B Electronics RS-422/485 Application Note for further information on biasing.

Figure 2

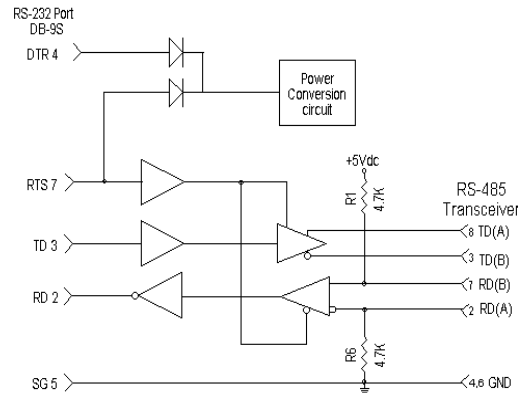

Specifications

Data Rate: 115.2K Baud max.

Power: Port Powered from RTS and DTR.

Note: If external power is required, apply power to DTR (4) and SG (5). Source must supply greater than 6VDC and current limited to 40mA

NOTE: When using an external supply, the supply should be connected only to specifically labeled power inputs (power jack, terminal block, etc.). Connecting an external power supply to the handshake lines may damage the unit. Contact technical support for more information on connecting an external power supply to the handshake lines.

DECLARATION OF CONFORMITY

Manufacturer's Name: B&B Electronics Manufacturing Company
 Manufacturer's Address: P.O. Box 1040
 707 Dayton Road
 Ottawa, IL 61350 USA
 Model Number: 485LP9R
 Description: 9-Pin Port-Powered RS-485 Converter
 Type: Light industrial ITE equipment
 Application of Council Directive: 89/336/EEC
 Standards: EN 50082-1 (IEC 801-2, IEC 801-3, IEC 801-4)
 EN 50081-1 (EN 55022, IEC 1000-4-2)
 EN 61000 (-4-2, -4-3, -4-4, -4-5, -4-6, -4-8, -4-11)
 ENV 50204
 EN 55024

Robert M. Paratore, Director of Engineering

