



Chipsmall Limited consists of a professional team with an average of over 10 year of expertise in the distribution of electronic components. Based in Hongkong, we have already established firm and mutual-benefit business relationships with customers from,Europe,America and south Asia,supplying obsolete and hard-to-find components to meet their specific needs.

With the principle of "Quality Parts,Customers Priority,Honest Operation,and Considerate Service",our business mainly focus on the distribution of electronic components. Line cards we deal with include Microchip,ALPS,ROHM,Xilinx,Pulse,ON,Everlight and Freescale. Main products comprise IC,Modules,Potentiometer,IC Socket,Relay,Connector.Our parts cover such applications as commercial,industrial, and automotives areas.

We are looking forward to setting up business relationship with you and hope to provide you with the best service and solution. Let us make a better world for our industry!



Contact us

Tel: +86-755-8981 8866 Fax: +86-755-8427 6832

Email & Skype: info@chipsmall.com Web: www.chipsmall.com

Address: A1208, Overseas Decoration Building, #122 Zhenhua RD., Futian, Shenzhen, China





4DLCD-32QA

Display Datasheet

Document Date: 23rd January 2015

Document Revision: 1.1

Table of Contents

1. Specifications	3
1.1 General Characteristics	3
1.2 Mechanical Specifications	4
1.3 Pin Descriptions.....	5
2. Electrical Specifications	6
2.1 Absolute Maximum Ratings	6
2.2 DC Characteristics	6
2.3 LED Backlight Maximum Ratings	6
3. Optical Characteristics	7
4. Touch Characteristics	8
5. Quality Testing	9
5.1 Reliability Tests.....	9
5.2 Color Performance	9
6. Precautions for Using LCD Modules	10
6.1 Handling Precautions	10
6.2 Storage Precautions	11
7. Using LCD Modules	12
7.1 Installing LCD Modules	12
7.2 Precautions for Operation.....	12
7.3 Safety.....	13
7.4 Return LCM under warranty	13

1. SPECIFICATIONS

1.1 General Characteristics

S.No.	Items	Specifications
1	Screen size (inch)	3.2" Diagonal
2	LCD Type	TFT, Normally White, TRANSMISSIVE
3	Colors	65K Colors
4	Display Resolution	240 x RGB x 320
5	Module Outline (mm)	55.04 x 77.7 x 2.4 (W x H x T)
6	Active Area (mm)	48.60 x 64.80 (W x H)
7	Touch Panel Dimension	76.2 x 53.4 x 1.2 (W x H x T)
8	Viewing Direction	12:00 O' Clock
9	Pixel Arrangement	RGB Vertical Stripe
10	Interface	8080, 8/16 bit CPU Interface
11	Assembly Type	Connector type FPC
12	Driver IC	ILI9341
13	Backlight	6 x White LED
14	Pixel Arrangement	RGB Vertical Stripe

1.2 Mechanical Specifications

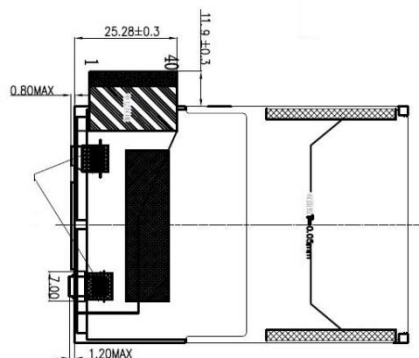
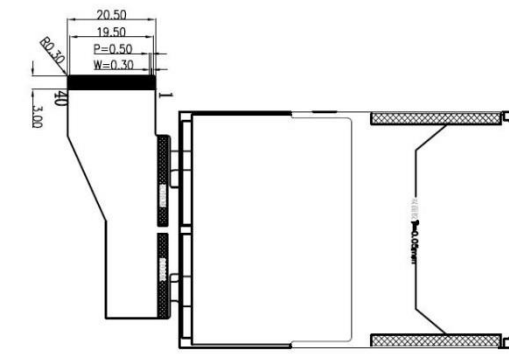
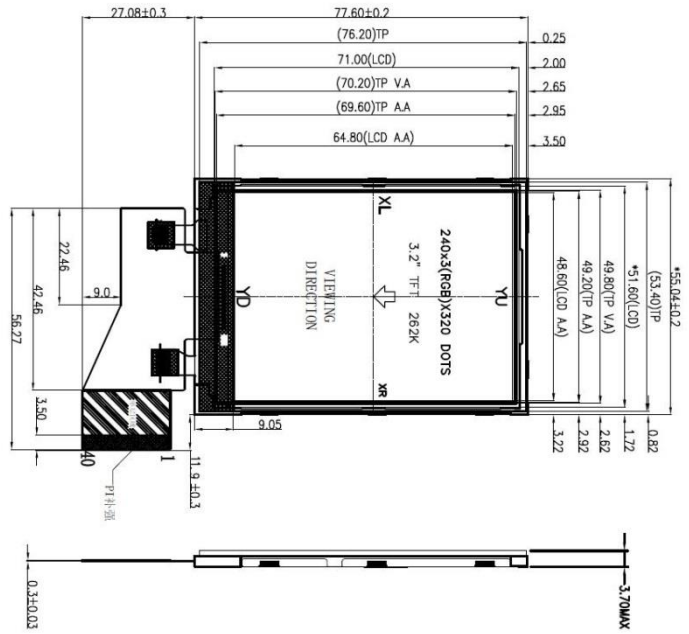

- NOTES:
- 1.DISPLAY TYPE: 3.2" TFT 262K, Transmissive
 - 2.OPERATING TEMP: -20°C~70°C
 - 3.STORAGE TEMP: -30°C~80°C
 - 4.LCD DRIVER: ILI93341
 - 5.VIEWING DIRECTION: 12 O'CLOCK
 - 8.THE TOLERANCE UNLESS CLASSIFIED±0.2mm

pin num	dir
pin 1	YU
pin 2	XL
pin 3	YD
pin 4	XR

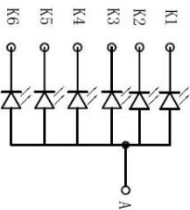

LED CIRCUIT DIAGRAM

NO.	Pin name
1	GND
2	GND
3	MICR(1/6)
4	PLANK
5	YD
6	XL
7	RESET
8	RS
9	CS
10	RD
11	WR
12	VCC=3.3V
13	NC
14	GND
15	DB15
16	DB14
17	DB13
18	DB12
19	DB11
20	DB10
21	DB9
22	DB8
23	DB7
24	DB6
25	DB0
26	DB1
27	DB2
28	DB3
29	DB4
30	DB5
31	YU
32	XR
33	LEDA
34	LEDK1
35	LEDK2
36	LEDK3
37	LEDK4
38	LEDK5
39	LEDK6
40	GND

1.3 Pin Descriptions

Pin	Symbol	I/O	Function
1	GND	Power	Ground
2	GND	Power	Ground
3	IMO(8/16)	Control	Interface Mode 0: for 16bit Mode 1: for 8bit Mode
4	FMARK	Control	Output a frame head pulse signal
5	Y- (Y _D)	INPUT	Touch Panel Y
6	X+ (X _L)	INPUT	Touch Panel X
7	RESET	INPUT	A Reset Signal
8	RS	INPUT	A Register select signal
9	CS	INPUT	A Chip select signal
10	RD	INPUT	Read signal
11	WR	INPUT	Write signal
12	VCC	Power	3.3V: Analog Power Supply
13	NC	-	Not Connected
14	GND	Power	Ground
15~22	DB15~ DB08	I/O	Parallel interface data bus
23	DB7	I/O	Parallel interface data bus
24	DB6	I/O	Parallel interface data bus
25	DB0	I/O	Parallel interface data bus
26	DB1	I/O	Parallel interface data bus
27	DB2	I/O	Parallel interface data bus
28	DB3	I/O	Parallel interface data bus
29	DB4	I/O	Parallel interface data bus
30	DB5	I/O	Parallel interface data bus
31	Y+(Y _U)	INPUT	Touch Panel Y
32	X- (X _R)	INPUT	Touch Panel X :
33	LEDA		LED Anode
34	LEDK1		LED cathode
35	LEDK2		LED cathode
36	LEDK3		LED cathode
37	LEDK4		LED cathode
38	LEDK5		LED cathode
39	LEDK6		LED cathode
40	GND		Power Ground

2. ELECTRICAL SPECIFICATIONS

2.1 Absolute Maximum Ratings

Items	Symbol	Condition	Min.	Max.	Unit
Power supply Voltage	V_{CI}	$T_a = +25^{\circ}\text{C}$	-0.3	+4.6	V
Operating Temperature	T_{OP}	-	-20	+70	$^{\circ}\text{C}$
Storage Temperature	T_{ST}	-	-30	+80	$^{\circ}\text{C}$
Storage Humidity	H_D	-	20	90	%RH

Cautions:

Any stresses exceeding the absolute Maximum Ratings may cause substantial damage to the device.

2.2 DC Characteristics

Items	Symbol	Conditions	Min.	Typ.	Max.	Unit
Power supply voltage	V_{CI}	$T_a = +25^{\circ}\text{C}$	2.5	-	3.3	V
Input High Voltage	V_{IH}		$0.8V_{CI}$	-	V_{CI}	V
Input Low Voltage	V_{IL}		GND	-	$0.2V_{CI}$	V
Output High Voltage	V_{OH}		$0.8V_{CI}$	-	-	V
Output Low Voltage	V_{OL}		-	-	$0.2V_{CI}$	V
Power consumption	P_{LCD}	Excluding Backlight	-	30	-	mW

2.3 LED Backlight Maximum Ratings

Items	Symbol	Conditions	Min.	Typ.	Max.	Unit	Comments
Forward Current	I_{LED}	$T_a = +25^{\circ}\text{C}$	18	20	25	mA	Single LED
Forward Voltage	V_F		3.2	3.3	3.6	V	Single LED
Power Dissipation	P_D		288	330	450	mW	Backlight unit

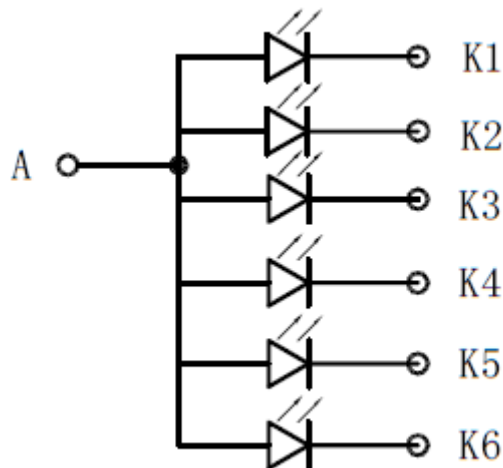

3. OPTICAL CHARACTERISTICS

The following items are measured under stable conditions. The optical characteristics should be measured in a dark room or equivalent state with the methods shown in Note (2).

Operating Conditions: $T_a = 25 \pm 2^\circ\text{C}$,

Item	Symbol	Condition	Min	Typ	Max	Unit
Brightness	L	White pattern	160	200	-	Cd/m^2
Response Time	$T_R + T_F$	$\theta = \phi = 0$	-	25	-	ms
Contrast Ratio	CR	At the Center point of A.A	300	350	-	
Color Chromaticity	White	W_X	0.237	0.313	0.353	
		W_Y	0.289	0.329	0.369	
Viewing Angle	Horizontal	$CR \geq 10$	-	110	-	Deg
	Vertical		-	120	-	Deg

Note1. These parameters are measured by C light.

Note2. Definition of Viewing Angle

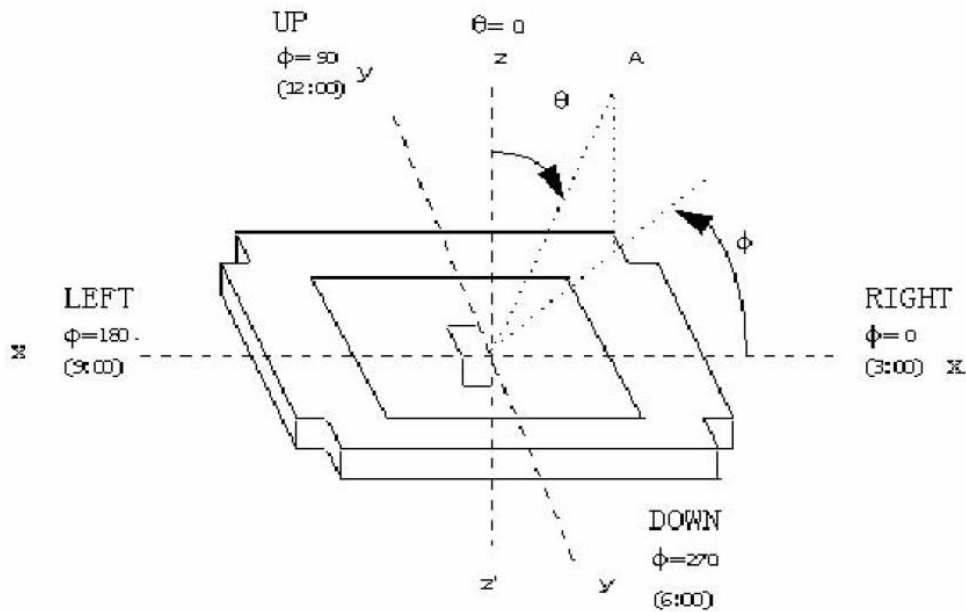

Note: The Screens used are the highest rated 'Grade A' Displays which allow for 0-4 defective pixels. A defective pixel could be solid Black (Dead), Red, Green or Blue. 4D Systems is not liable for a return/replacement for any Display that has 4 or less defective pixels.

4. TOUCH CHARACTERISTICS

Touch Parameters					
Parameter	Conditions	Min	Typ	Max	Units
Operating Voltage		-	5	-	V
Linearity		±1.5			%
Terminal Resistance X	X film side	300	400	800	Ohm
Terminal Resistance Y	Y film side	300	600	800	Ohm
Operating Temperature		-10	-	60	°C
Storage Temperature		-20	-	70	°C
Transmittance		80	-	-	%
Life Time – Tapping Durability		1	-	-	Million
Life Time – Pen Durability	Stylus Pen or Finger Press	1	-	-	Million
Response Time				10	ms

- **ITO Film:** Single Layer/Clear Hard Coating
- **Tail Type:** FPC by Golden Plated
- **Connection:** FPC Connector
- **RoHS Compliant**

5. QUALITY TESTING

The LCD Module should be designed to meet a minimum MTTF value of 50,000hrs under normal operating conditions. T = 25°C, Indoors, Not exposed to sunlight. Note, Backlight life time is not included.

Criterion:

- No defect of Operational Function in Room Temperature is allowable-
- Leakage current should be below double the initial value-

5.1 Reliability Tests

S. No.	Item	Condition	Pass/Fail
1	High Temperature Operating	70°C, 240hrs	Pass
2	Low Temperature Operating	-20°C, 240hrs	Pass
3	High Temperature Non-Operating	80°C, 240hrs	Pass
4	Low Temperature Non-Operating	-30°C, 240hrs	Pass
5	High Temperature/Humidity Non-Operating	50°C, 90% RH, 240hrs	Pass
6	Temperature Shock Non-Operating	-30°C ← → 80°C, 10 cycles 30min----5min----30min	Pass
7	Electro-Static Discharge	HBM: ±2KV	Pass

Note1: Test after 24 hrs in room temperature.

Note2: The sampling above is individual for each reliability testing.

Note3: The color fading of polarization filter should not care.

Note4: The entire reliability testing chamber above is using D.I. water (Min value: 1.0MΩ-cm)

Note5: In case of malfunction defect cause by the ESD Damage, If it could be recovered to normal state after resetting, it would be considered as a good part.

5.2 Color Performance

S. No.	Item	Condition
1	Luminance	> 50%
2	NTSC	> 70%
3	Contrast Ratio	> 50%

6. PRECAUTIONS FOR USING LCD MODULES

6.1 Handling Precautions

- The display panel is made of glass and polarizer. The glass is fragile. It tends to become or chipped during handling especially on the edges. Please avoid dropping or jarring. Do not subject it to a mechanical shock by dropping it or impact.
- If the display panel is damaged and the liquid crystal substance leaks out, be sure not to get any in your mouth. If the substance contacts your skin or clothes, wash it off using soap and water.
- Do not apply excessive force to the display surface or the adjoining areas since this may cause the color tone to vary. Do not touch the display with bare hands. This will stain the display area and degraded insulation between terminals (some cosmetics are determined to the polarizer).
- The polarizer covering the display surface of the LCD module is soft and easily scratched. Handle this polarizer carefully. Do not touch, push or rub the exposed polarizer with anything harder than an HB pencil lead (glass, tweezers, etc.). Do not put or attach anything on the display area to avoid leaving marks on. Condensation on the surface and contact with terminals due to cold will damage, stain or dirty the polarizer. After products are tested at low temperature they must be warmed up in a container before coming is contacting with room temperature air.
- If the display surface becomes contaminated, breathe on the surface and gently wipe it with a soft dry cloth. If it is heavily contaminated, moisten cloth with one of the following solvents
 - Isopropyl alcohol
 - Ethyl alcohol

Do not scrub hard to avoid damaging the display surface.

- Solvents other than those above-mentioned may damage the polarizer. Especially, do not use the following.
 - Water
 - Ketone
 - Aromatic solvents

Wipe off saliva or water drops immediately, contact with water over a long period of time may cause deformation or color fading. Avoid contacting oil and fats.

- Exercise care to minimize corrosion of the electrode. Corrosion of the electrodes is accelerated by water droplets, moisture condensation or a current flow in a high-humidity environment.
- Install the LCD Module by using the mounting holes. When mounting the LCD module make sure it is free of twisting, warping and distortion. In particular, do not forcibly pull or bend the I/O cable or the backlight cable.
- Do not attempt to disassemble or process the LCD module.
- NC terminal should be open. Do not connect anything.
- If the logic circuit power is off, do not apply the input signals.
- Electro-Static Discharge Control. Since this module uses a CMOS LSI, the same careful attention should be paid to electrostatic discharge as for an ordinary CMOS IC. To prevent destruction of the elements by static electricity, be careful to maintain an optimum work environment.
 - Before remove LCM from its packing case or incorporating it into a set, be sure the module and your body have the same electric potential. Be sure to ground the body when handling the LCD modules.
 - To reduce the amount of static electricity generated, do not conduct assembling and other work under dry conditions. To reduce the generation of static electricity be careful that the air in the work is not too dried. A relative humidity of 50%-60% is recommended. As far as possible make the electric potential of your work clothes and that of the work bench the ground potential
 - The LCD module is coated with a film to protect the display surface. Exercise care when peeling off this protective film since static electricity may be generated.
- Since LCM has been assembled and adjusted with a high degree of precision, avoid applying excessive shocks to the module or making any alterations or modifications to it.

- Do not alter, modify or change the shape of the tab on the metal frame.
- Do not make extra holes on the printed circuit board, modify its shape or change the positions of components to be attached.
- Do not damage or modify the pattern writing on the printed circuit board.
- Absolutely do not modify the zebra rubber strip (conductive rubber) or heat seal connector.
- Do not drop, bend or twist LCM.

6.2 Storage Precautions

- When storing the LCD modules, the following precaution is necessary.
- Store them in a sealed polyethylene bag. If properly sealed, there is no need for the desiccant.
- Store them in a dark place. Do not expose to sunlight or fluorescent light, keep the temperature between 0°C and 35°C, and keep the relative humidity between 40%RH and 60%RH.
- The polarizer surface should not come in contact with any other objects. (We advise you to store them in the anti-static electricity container in which they were shipped. Others Liquid crystals solidify under low temperature (below the storage temperature range) leading to defective orientation or the generation of air bubbles (black or white). Air bubbles may also be generated if the module is subject to a low temperature.
- If the LCD modules have been operating for a long time showing the same display patterns, the display patterns may remain on the screen as ghost images and a slight contrast irregularity may also appear. A normal operating status can be regained by suspending use for some time. It should be noted that this phenomenon does not adversely affect performance reliability.
- To minimize the performance degradation of the LCD modules resulting from destruction caused by static electricity etc., exercise care to avoid holding the following sections when handling the modules'
 - Exposed area of the printed circuit board
 - Terminal electrode sections

7. USING LCD MODULES

7.1 Installing LCD Modules

The hole in the printed circuit board is used to fix LCM as shown in the picture below. Attend to the following items when installing the LCM.

1. Cover the surface with a transparent protective plate to protect the polarizer and LC cell.

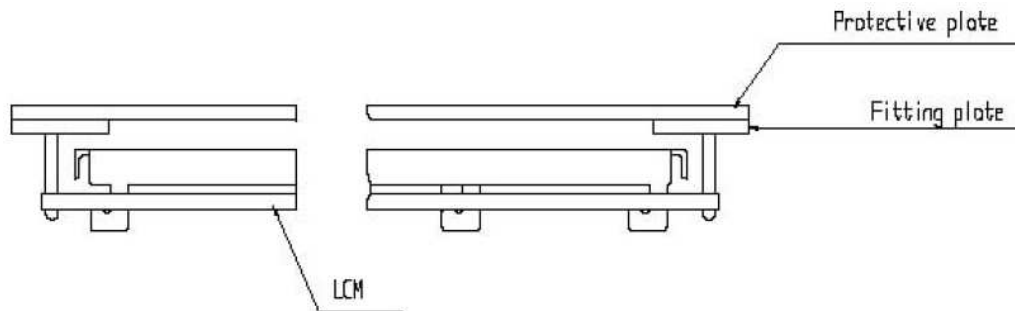

2. When assembling the LCM into other equipment, the spacer to the bit between the LCM and the fitting plate should have enough height to avoid causing stress to the module surface, refer to the individual specifications for measurements. The measurement tolerance should be $\pm 0.1\text{mm}$. Precaution for assemble the module with BTB connector:

Please note the position of the male and female connector position, don't assemble or assemble like the method which the following picture shows.

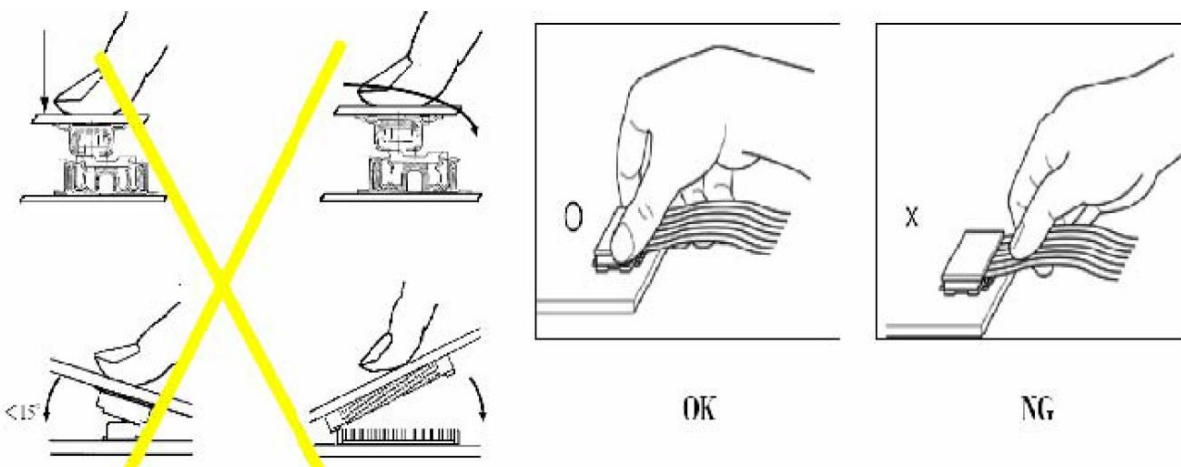

7.2 Precautions for Operation

1. Viewing angle varies with the change of liquid crystal driving voltage (VLCD). Adjust VLCD to show the best contrast.
2. It is an indispensable condition to drive LCD's within the specified voltage limit since the higher voltage than the limit cause the shorter LCD life. An electrochemical reaction due to direct current causes LCD's undesirable deterioration, so that the use of direct current drive should be avoided.
3. Response time will be extremely delayed at lower temperature than the operating temperature range and on the other hand at higher temperature LCD's show dark color in them. However those phenomena do not mean malfunction or out of order with LCD's, which will come back in the specified operating temperature.
4. If the display area is pushed hard during operation, the display will become abnormal. However, it will return to normal if it is turned off and then back on.

5. Slight dew depositing on terminals is a cause for electro-chemical reaction resulting in terminal open circuit. Usage under the maximum operating temperature, 50%RH or less is required.
6. Input each signal after the positive/negative voltage becomes stable.
7. Please keep the temperature within specified range for use and storage. Polarization degradation, bubble generation or polarizer peel-off may occur with high temperature and high humidity.

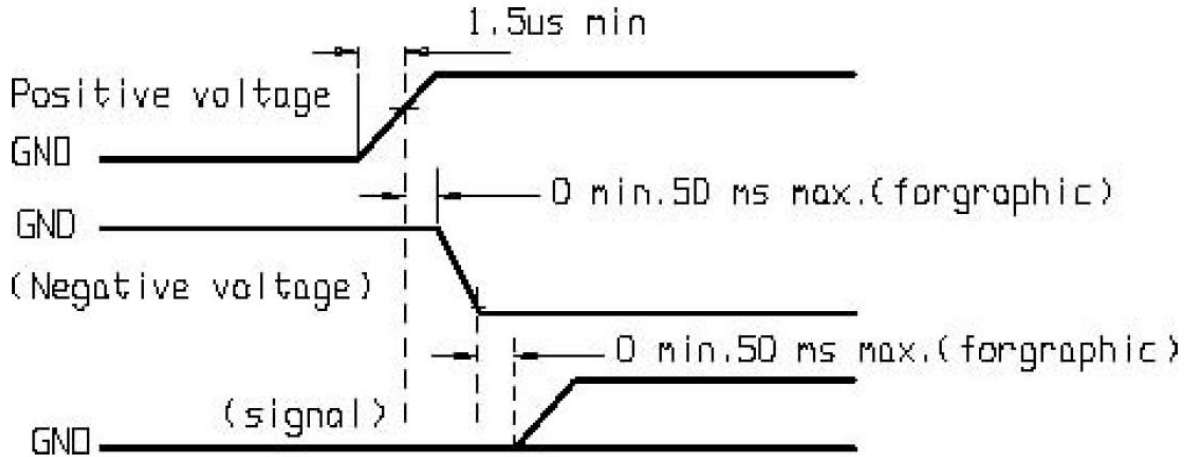

7.3 Safety

- It is recommended to crush damaged or unnecessary LCDs into pieces and wash them off with solvents such as acetone and ethanol, which should later be burned.
- If any liquid leaks out of a damaged glass cell and comes in contact with the hands, wash off thoroughly with soap and water. Limited Warranty.

7.4 Return LCM under warranty

No warranty can be granted if the precautions stated above have been disregarded. The typical examples of violations are,

- Broken LCD glass.
- PCB eyelet is damaged or modified.
- PCB conductors damaged.
- Circuit modified in any way, including addition of components.
- PCB tampered with by grinding, engraving or painting varnish.

Module repairs will be invoiced to the customer upon mutual agreement. Modules must be returned with sufficient description of the failures or defects. Any connectors or cable installed by the customer must be removed completely without damaging the PCB eyelet, conductors and terminals.

PROPRIETARY INFORMATION

The information contained in this document is the property of 4D Systems Pty. Ltd. and may be the subject of patents pending or granted, and must not be copied or disclosed without prior written permission.

4D Systems endeavors to ensure that the information in this document is correct and fairly stated but does not accept liability for any error or omission. The development of 4D Systems products and services is continuous and published information may not be up to date. It is important to check the current position with 4D Systems. 4D Systems reserves the right to modify, update or make changes to Specifications or written material without prior notice at any time.

All trademarks belong to their respective owners and are recognized and acknowledged.

DISCLAIMER OF WARRANTIES & LIMITATION OF LIABILITY

4D Systems makes no warranty, either express or implied with respect to any product, and specifically disclaims all other warranties, including, without limitation, warranties for merchantability, non-infringement and fitness for any particular purpose.

Information contained in this publication regarding device applications and the like is provided only for your convenience and may be superseded by updates. It is your responsibility to ensure that your application meets with your specifications.

In no event shall 4D Systems be liable to the buyer or to any third party for any indirect, incidental, special, consequential, punitive or exemplary damages (including without limitation lost profits, lost savings, or loss of business opportunity) arising out of or relating to any product or service provided or to be provided by 4D Systems, or the use or inability to use the same, even if 4D Systems has been advised of the possibility of such damages.

4D Systems products are not fault tolerant nor designed, manufactured or intended for use or resale as on line control equipment in hazardous environments requiring fail – safe performance, such as in the operation of nuclear facilities, aircraft navigation or communication systems, air traffic control, direct life support machines or weapons systems in which the failure of the product could lead directly to death, personal injury or severe physical or environmental damage ('High Risk Activities'). 4D Systems and its suppliers specifically disclaim any expressed or implied warranty of fitness for High Risk Activities.

Use of 4D Systems' products and devices in 'High Risk Activities' and in any other application is entirely at the buyer's risk, and the buyer agrees to defend, indemnify and hold harmless 4D Systems from any and all damages, claims, suits, or expenses resulting from such use. No licenses are conveyed, implicitly or otherwise, under any 4D Systems intellectual property rights.

CONTACT INFORMATION

For Technical Support: support@4dsystems.com.au

For Sales Support: sales@4dsystems.com.au

Website: www.4dsystems.com.au

Copyright 4D Systems Pty. Ltd. 2000-2015.