



Chipsmall Limited consists of a professional team with an average of over 10 year of expertise in the distribution of electronic components. Based in Hongkong, we have already established firm and mutual-benefit business relationships with customers from,Europe,America and south Asia,supplying obsolete and hard-to-find components to meet their specific needs.

With the principle of "Quality Parts,Customers Priority,Honest Operation,and Considerate Service",our business mainly focus on the distribution of electronic components. Line cards we deal with include Microchip,ALPS,ROHM,Xilinx,Pulse,ON,Everlight and Freescale. Main products comprise IC,Modules,Potentiometer,IC Socket,Relay,Connector.Our parts cover such applications as commercial,industrial, and automotives areas.

We are looking forward to setting up business relationship with you and hope to provide you with the best service and solution. Let us make a better world for our industry!



## Contact us

Tel: +86-755-8981 8866 Fax: +86-755-8427 6832

Email & Skype: info@chipsmall.com Web: www.chipsmall.com

Address: A1208, Overseas Decoration Building, #122 Zhenhua RD., Futian, Shenzhen, China



LOC		DIST		REVISIONS			
P	LTN	DESCRIPTION	DATE	DMN	APVD		
D1		REVISED PER ECO-11-005027	14MAR2011	RK	HMR		
E		REV: ECO-12-010973	14JUN2012	GG	JG		
F		REVISED PER ECO-12-012703	03JULY2012	JB	JG		

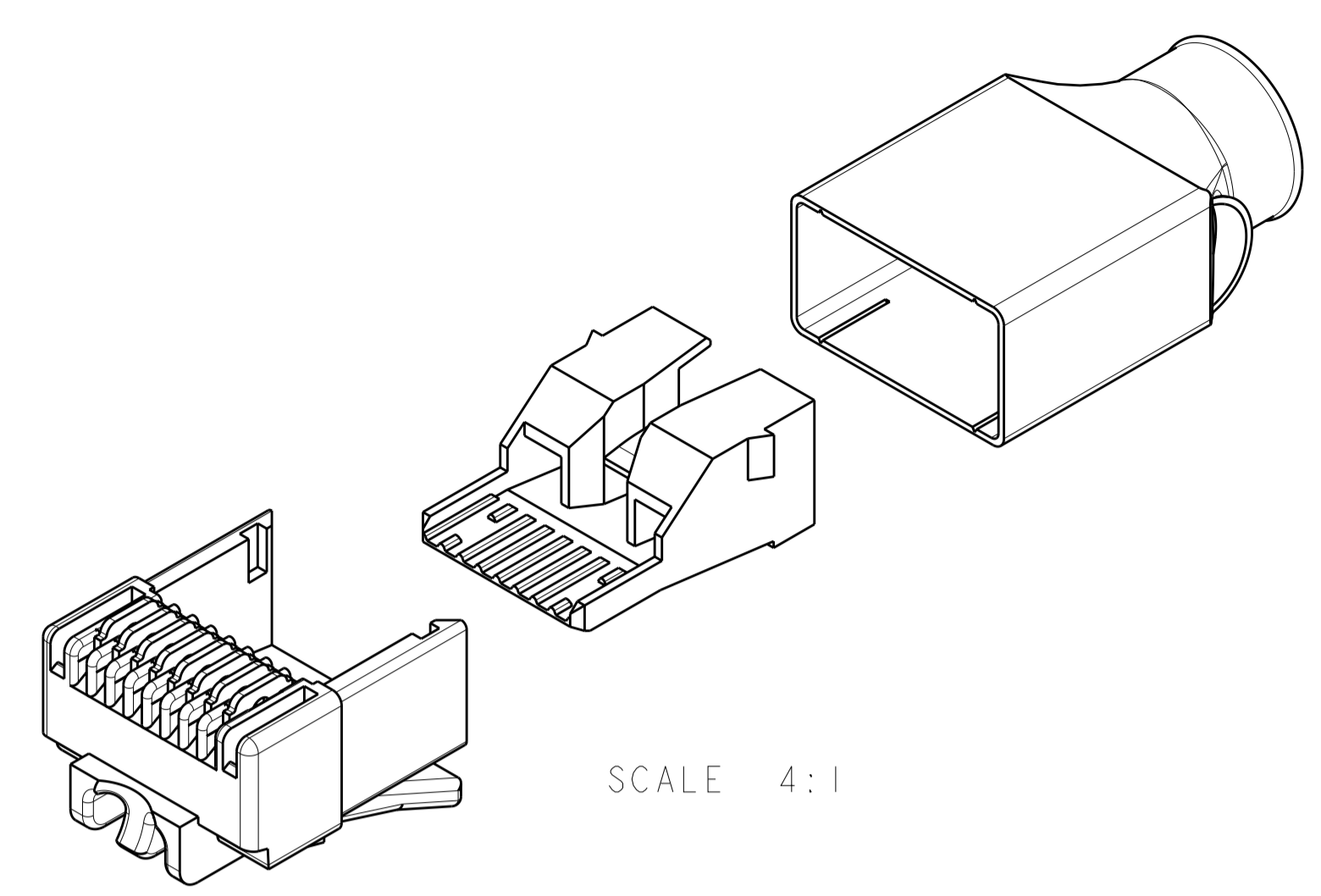

SCALE 4:1

- 1. MATERIAL: HOUSING - 94V-0 RATED POLYCARBONATE CLEAR TERMINAL - 0.36 [0.014] THICK PHOSPHOR BRONZE PLATED WITH 1.27  $\mu\text{m}$  [0.00050] MINIMUM THICK GOLD IN LOCALIZED AREA OVER 2.54  $\mu\text{m}$  [0.00100] MINIMUM THICK NICKEL UNDERPLATE. WIRE HOLDER - POLYCARBONATE MAKROLON CLEAR. SHIELD - BRASS DIN 17660 - CuZn33
- 2. DIMENSIONS ARE NOMINAL UNLESS OTHERWISE SPECIFIED.
- 3. PLUG WILL ACCEPT A 23-24 AWG SOLID CONDUCTOR, PROVIDED THE INSULATION CONDUCTOR DIAMETER IS WITHIN .89 - 1.09 [0.035 - .043]; WITH THE SUM OF DIAMETERS FOR ALL EIGHT CONDUCTORS WITHIN THE CABLE MUST NOT EXCEED 7.8MM [0.31 IN]. CABLE JACKET DIAMETER OF 6.0 - 7.0 MM [0.24 - .28 IN].
- 4. TERMINATED DIMENSION 6.15 [0.242] MAXIMUM.
- 5. PACKAGE 1,000 ASSEMBLIES, 1,000 WIRE HOLDERS, AND 1,000 SHIELDS.
- 6. PACKAGE 100 ASSEMBLIES, 100 WIRE HOLDERS, AND 100 SHIELDS.
- 8. PACKAGE 500 ASSEMBLIES, 500 WIRE HOLDERS, AND 500 SHIELDS.
- 9. MODULAR PLUG BOOT PART NUMBER 1711510-X (X-DENOTES VARIOUS COLORS) MAY BE USED WITH KIT ASSEMBLY SHOWN.
- 10. UL RECOGNIZED: FILE NUMBER E81956.

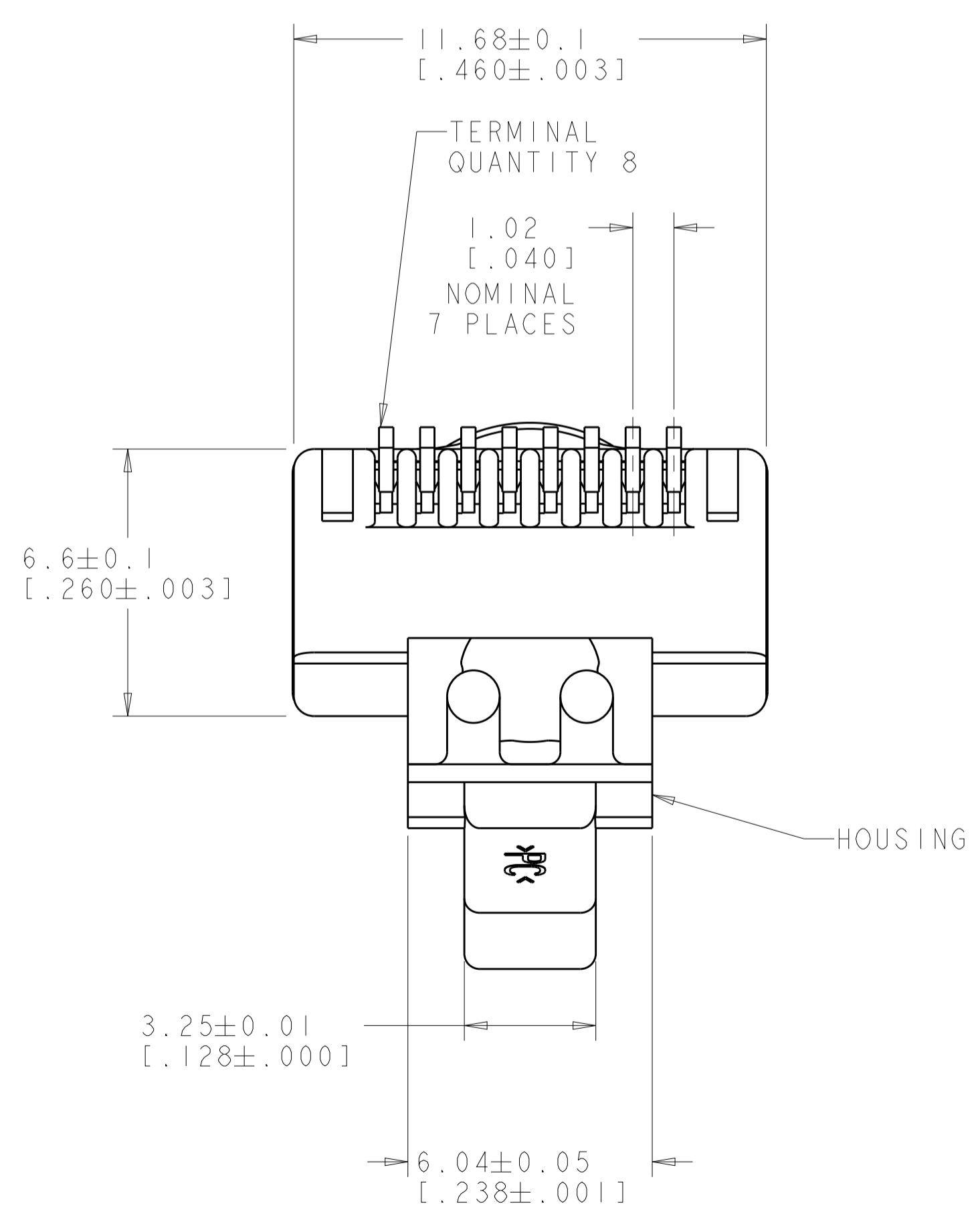
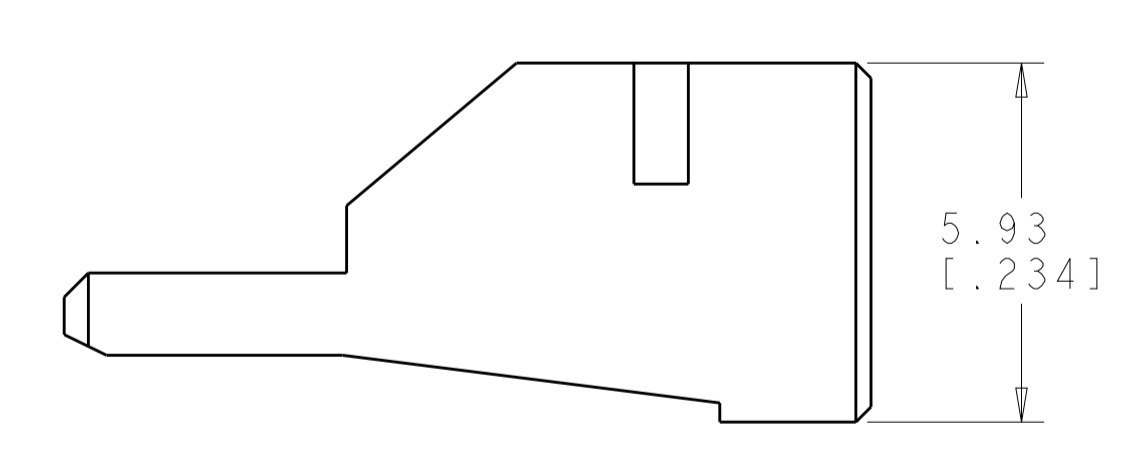
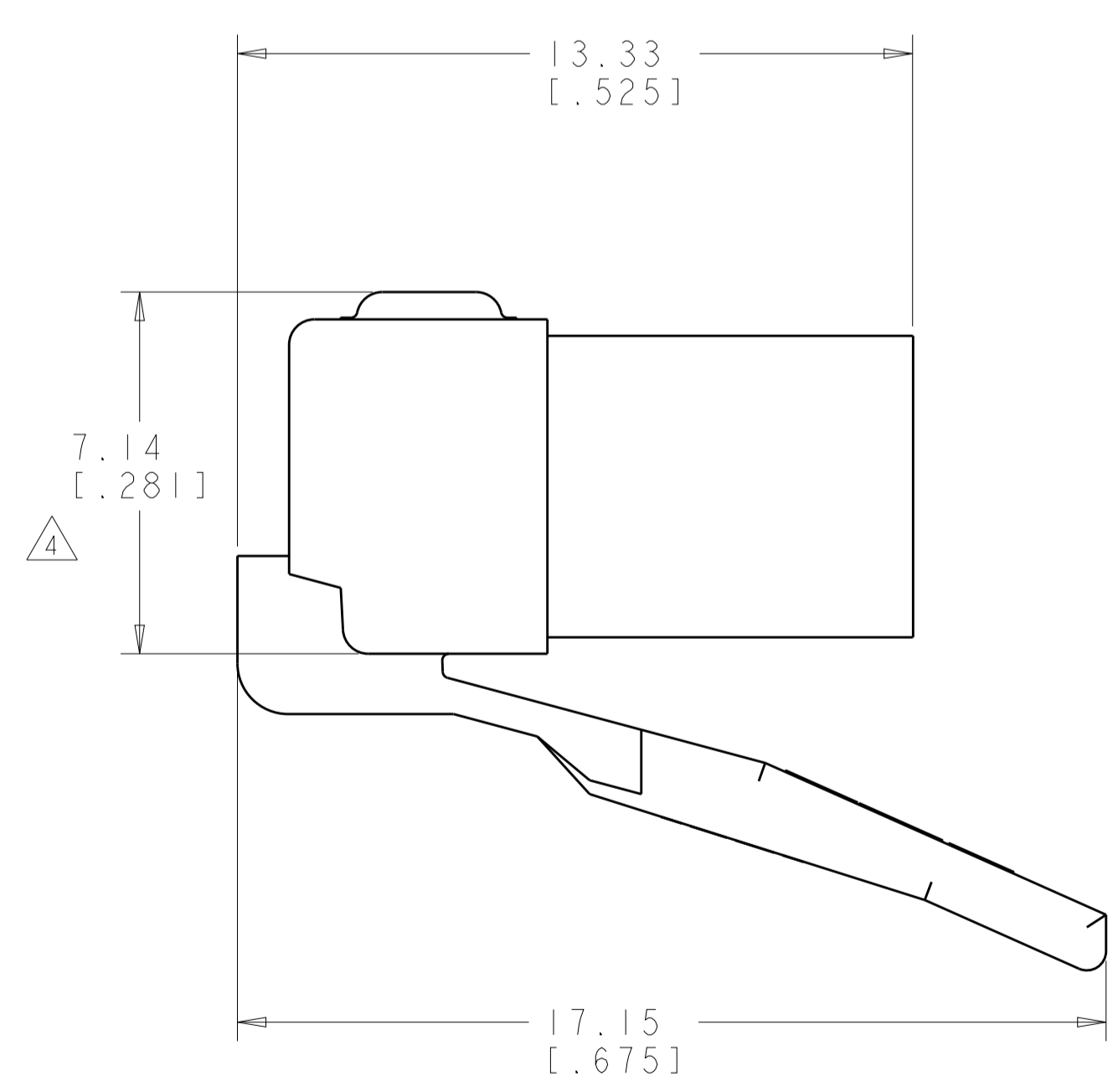
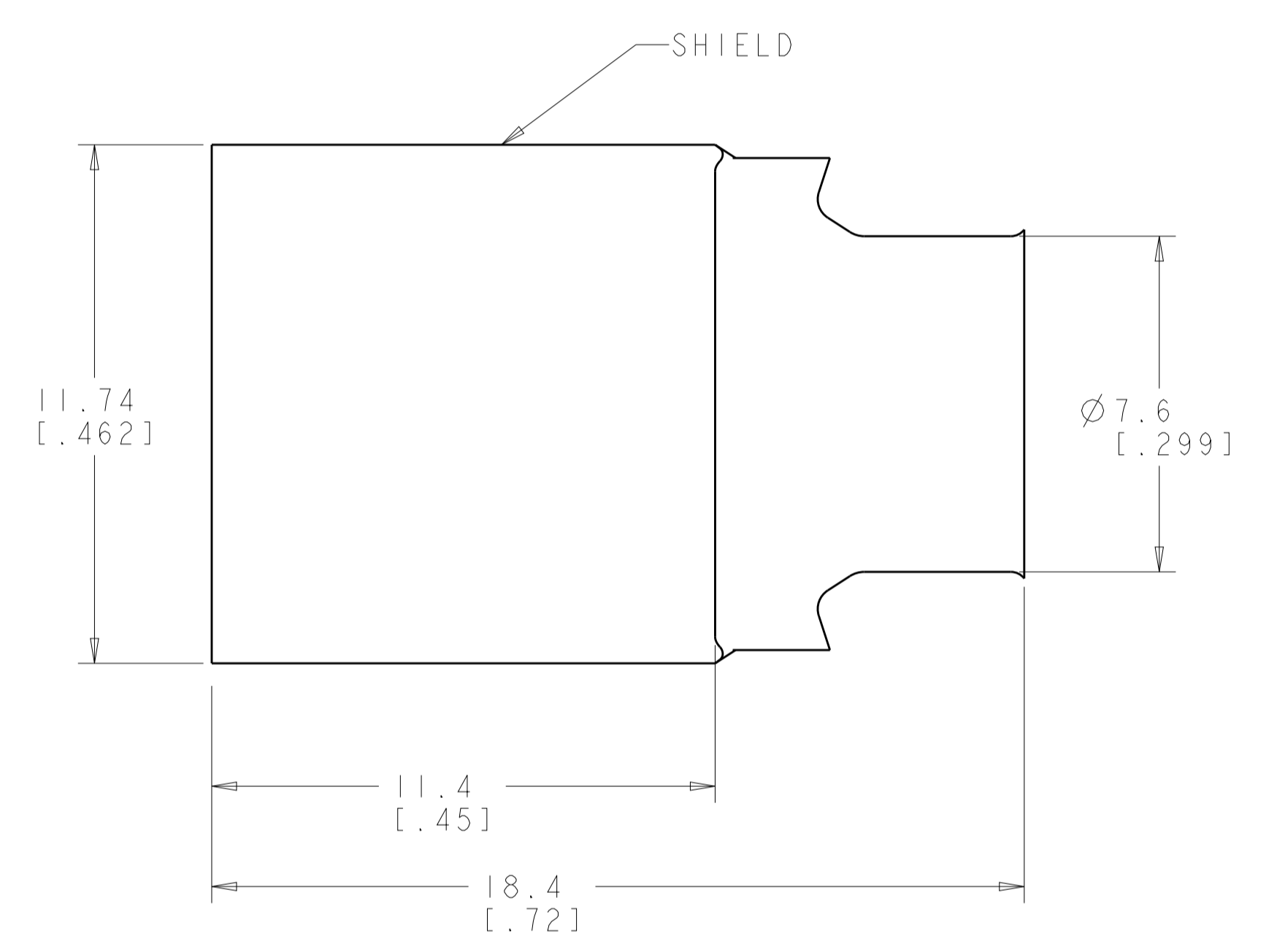
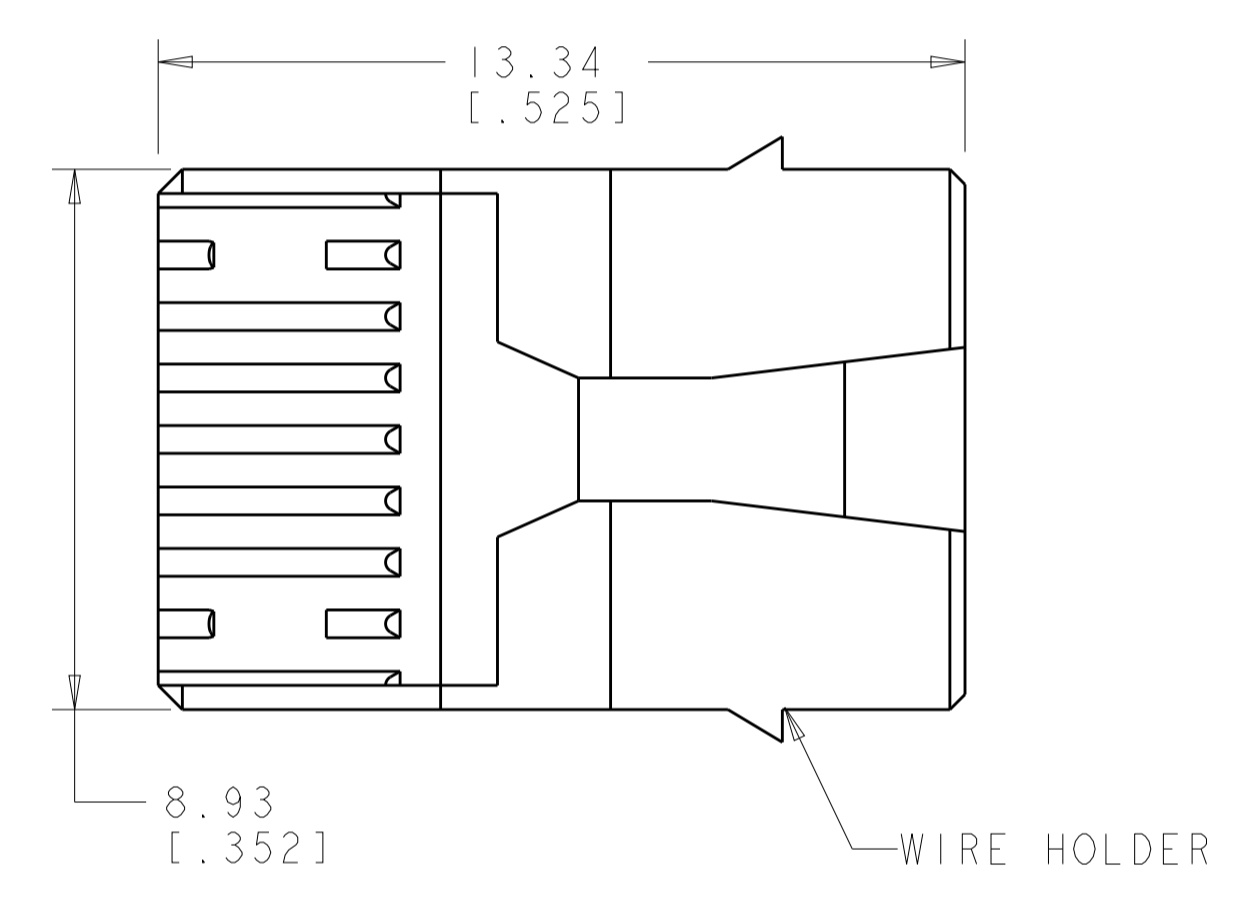
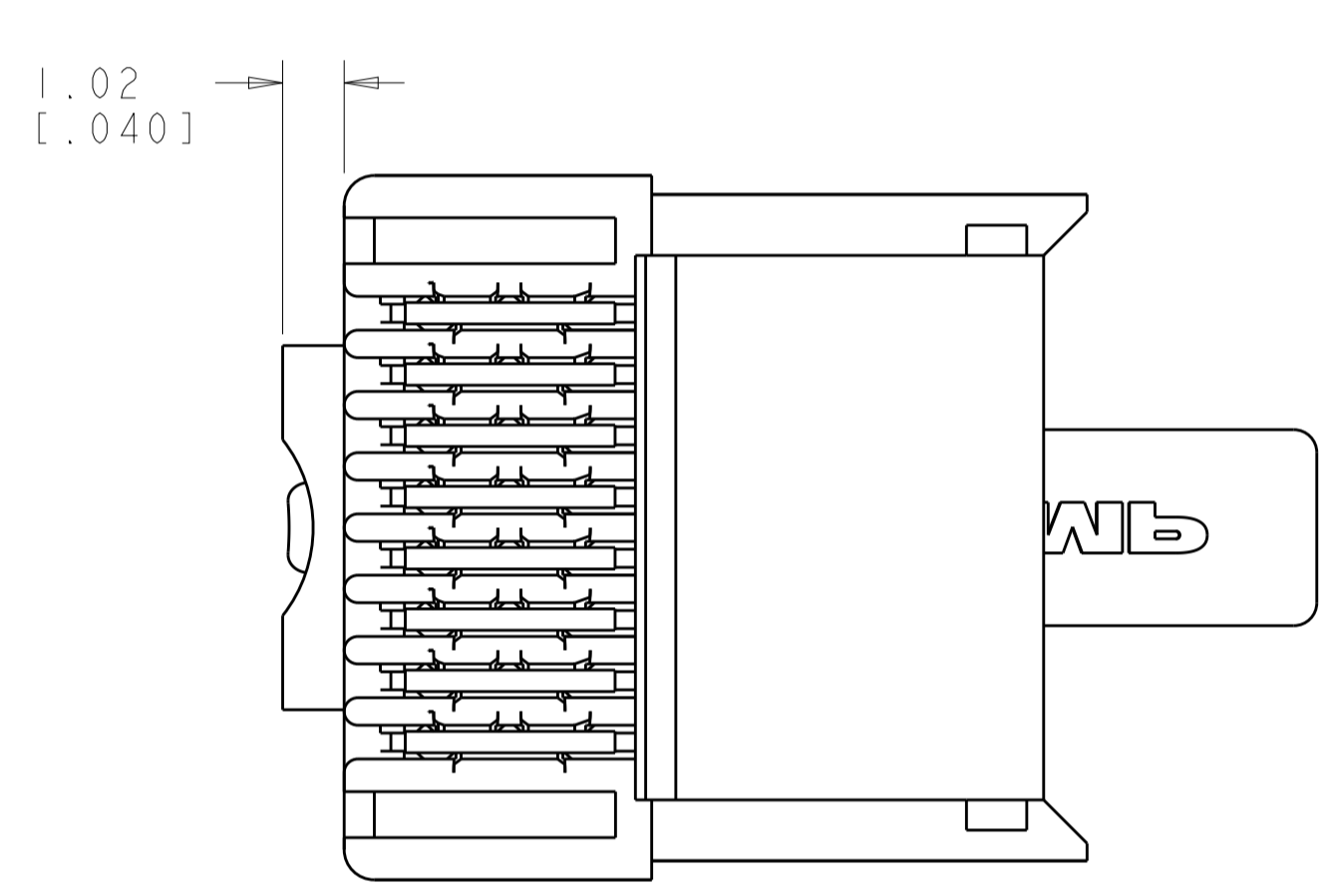

6	5-1479185-3
8	5-1479185-2
5	5-1479185-1
PACKAGE	PART NO.

THIS DRAWING IS A CONTROLLED DOCUMENT.

DIMENSIONS: MM [INCHES]	TOLERANCES UNLESS OTHERWISE SPECIFIED:	DMN: G. GARRETT 24JAN02	CHK: M. DELPHIAS 24JAN02	APVD: M. DELPHIAS 24JAN02	NAME: KIT, 8 POSITION, MODULAR PLUG, SOLID WIRE, CATEGORY 6
0 PLC ±	1 PLC ±	2 PLC ±	3 PLC ±	4 PLC ±	ANGLES ±
MATERIAL: $\triangle$		FINISH: $\triangle$		SIZE: A1	CAGE CODE: 1479185
CUSTOMER DRAWING				SCALE: 8:1	SHEET 1 OF 1

TE Connectivity