



Chipsmall Limited consists of a professional team with an average of over 10 year of expertise in the distribution of electronic components. Based in Hongkong, we have already established firm and mutual-benefit business relationships with customers from,Europe,America and south Asia,supplying obsolete and hard-to-find components to meet their specific needs.

With the principle of “Quality Parts,Customers Priority,Honest Operation,and Considerate Service”,our business mainly focus on the distribution of electronic components. Line cards we deal with include Microchip,ALPS,ROHM,Xilinx,Pulse,ON,Everlight and Freescale. Main products comprise IC,Modules,Potentiometer,IC Socket,Relay,Connector.Our parts cover such applications as commercial,industrial, and automotives areas.

We are looking forward to setting up business relationship with you and hope to provide you with the best service and solution. Let us make a better world for our industry!



## Contact us

Tel: +86-755-8981 8866 Fax: +86-755-8427 6832

Email & Skype: info@chipsmall.com Web: www.chipsmall.com

Address: A1208, Overseas Decoration Building, #122 Zhenhua RD., Futian, Shenzhen, China



THIS DRAWING IS UNPUBLISHED. RELEASED FOR PUBLICATION  
 © COPYRIGHT - By - ALL RIGHTS RESERVED.

| LOC | DIST | REVISIONS |     |                       |           |     |      |
|-----|------|-----------|-----|-----------------------|-----------|-----|------|
|     |      | P         | LTR | DESCRIPTION           | DATE      | DWN | APVD |
| HM  | 00   | J         |     | REV PER ECO-12-012918 | 05JUL2012 | JM  | JG   |

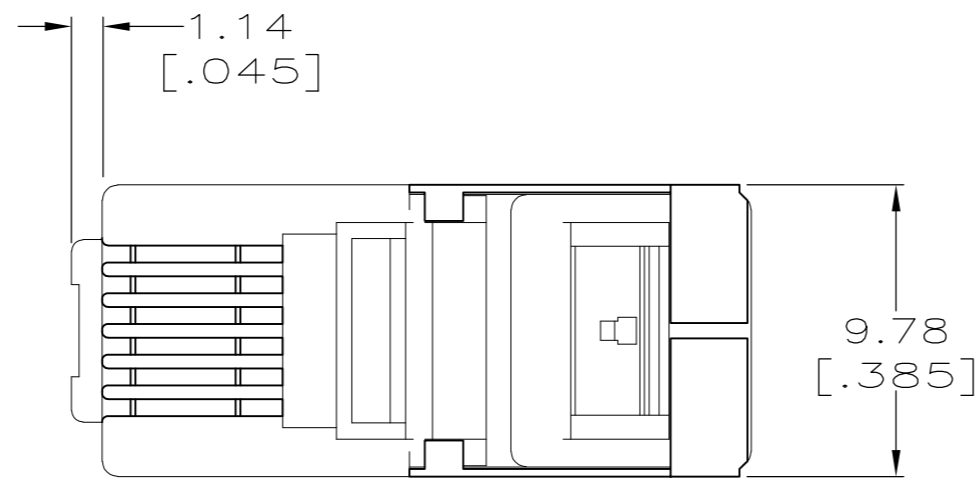

1 MATERIAL: HOUSING - POLYCARBONATE, CLEAR.  
 TERMINAL - 0.36[.014] THICK PHOSPHOR BRONZE PLATED WITH 1.27 $\mu$ m[.000050] THICK GOLD IN LOCALIZED GOLD PLATE AREA, OVER 2.54 $\mu$ m[.000100] THICK NICKEL UNDERPLATE.  
 SHIELD - 0.25[.010] THICK COPPER ALLOY, SATIN NICKEL PLATED.

2. ALL DIMENSIONS SHOWN ARE MAXIMUM UNLESS OTHERWISE SPECIFIED.

3. PLUG WILL ACCEPT 0.74-0.99[.029-.039] DIAMETER STRANDED WIRE, 26 OR 28 AWG, WITH A .180 DIAMETER MAXIMUM JACKET.

4 TERMINATED DIMENSION: 6.15[.242] MAXIMUM.

5 LATCH SHALL BE IN POSITION SHOWN IN DETAIL "A" AFTER CRIMPING.

7 500 ASSEMBLIES PER PACKAGE.

8 100 ASSEMBLIES PER PACKAGE.

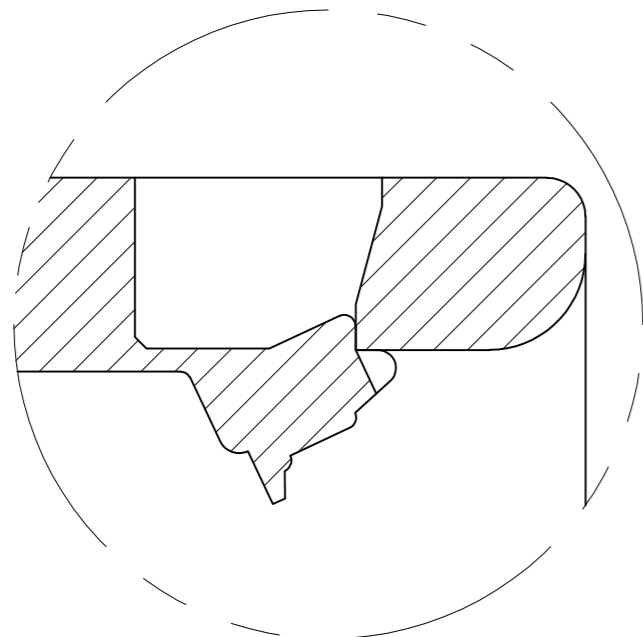
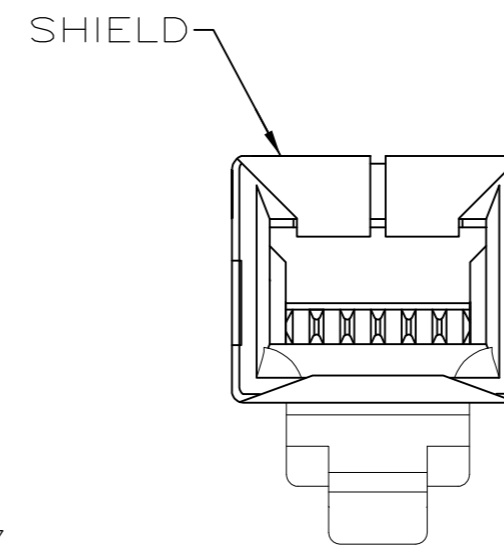
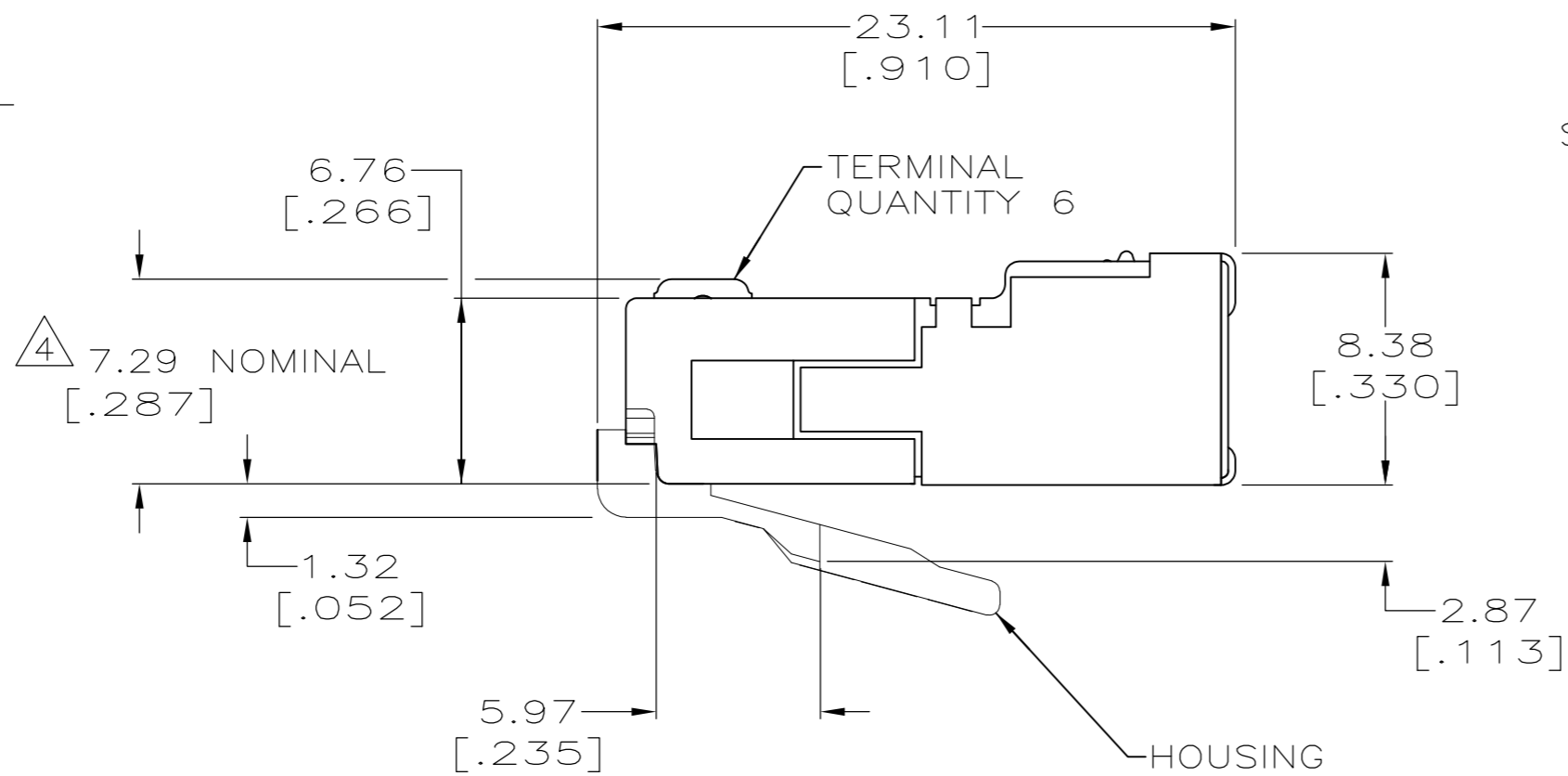
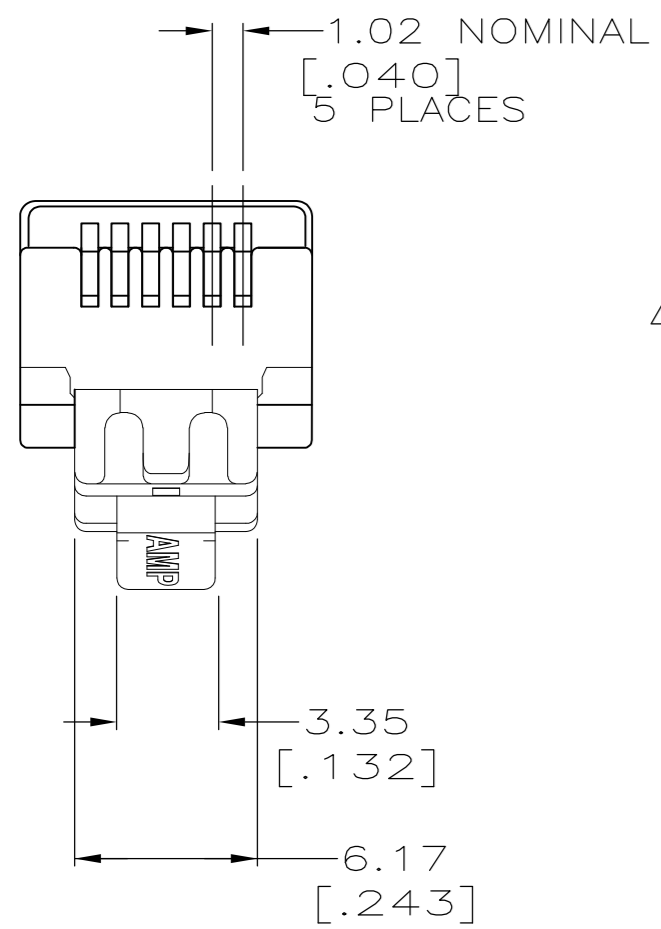

5 DETAIL A  
 LATCH POSITION AFTER CRIMPING  
 SCALE 10:1

|          |             |
|----------|-------------|
| 8        | 5-555175-3  |
| 7        | 5-555175-2  |
| PACKAGED | PART NUMBER |

|  |  |  |           |                    |  |  |           |            |     |
|--|--|--|-----------|--------------------|--|--|-----------|------------|-----|
| THIS DRAWING IS A CONTROLLED DOCUMENT. |  | DWN                                    | VIC SLACK | 11 MAR 87          |  | TE Connectivity  |           |            |     |
|  |  | CHK                                    | BOB FOX   | 16 MAR 87          |  | NAME   |           |            |     |
|  |  | APVD                                   | GENE REED | 31 MAR 87          |  | MODULAR PLUG ASSEMBLY,<br>6 POSITION, LONG BODY, SHIELDED,<br>ROUND CABLE, STRANDED WIRE |           |            |     |
|  |  | PRODUCT SPEC                           |           |                    |  | RESTRICTED TO  |           |            |     |
| DIMENSIONS:<br>mm [INCHES]             |  | TOLERANCES UNLESS OTHERWISE SPECIFIED: |           | APPLICATION SPEC   |  | SIZE   | CAGE CODE | DRAWING NO | REV |
| 0 PLC ± -                              |  | 1 PLC ± -                              |           | 2 PLC ± 0.13[.005] |  | A2   | 00779     | C=555175   | J   |
| 3 PLC ± -                              |  | 4 PLC ± -                              |           | ANGLES ± -         |  | SCALE  | SHEET     | 1 of 1     | REV |
| MATERIAL                               |  | FINISH                                 |           | WEIGHT             |  | 4:1  | 1         |            | J   |
| 1 -                                    |  | 1 -                                    |           | -                  |  | CUSTOMER DRAWING   |           |            |     |