



Chipsmall Limited consists of a professional team with an average of over 10 year of expertise in the distribution of electronic components. Based in Hongkong, we have already established firm and mutual-benefit business relationships with customers from,Europe,America and south Asia,supplying obsolete and hard-to-find components to meet their specific needs.

With the principle of “Quality Parts,Customers Priority,Honest Operation,and Considerate Service”,our business mainly focus on the distribution of electronic components. Line cards we deal with include Microchip,ALPS,ROHM,Xilinx,Pulse,ON,Everlight and Freescale. Main products comprise IC,Modules,Potentiometer,IC Socket,Relay,Connector.Our parts cover such applications as commercial,industrial, and automotives areas.

We are looking forward to setting up business relationship with you and hope to provide you with the best service and solution. Let us make a better world for our industry!



Contact us

Tel: +86-755-8981 8866 Fax: +86-755-8427 6832

Email & Skype: info@chipsmall.com Web: www.chipsmall.com

Address: A1208, Overseas Decoration Building, #122 Zhenhua RD., Futian, Shenzhen, China



THIS DRAWING AND THE SUBJECT MATTER SHOWN THEREON ARE CONFIDENTIAL AND THE PROPERTY OF BEL/STEWART/TRP CONNECTOR AND SHALL NOT BE REPRODUCED, COPIED, OR USED IN ANY MANNER WITHOUT THE WRITTEN CONSENT OF TRP CONNECTOR.

PRODUCT MAY BE PROTECTED BY ONE OR MORE OF THE FOLLOWING US PATENTS:
 5736910 5939955 6425781 6428361 6554638 6840817 7123117
 7429195 7717749 7808751 6217391 6149050 7924130

REVISIONS					
P	LYR	DESCRIPTION	DATE	DWN	APVD
G		EC-1411035 COMPANY LOGO CHANGE	12JAN2015	HY	KZ

MECHANICAL:

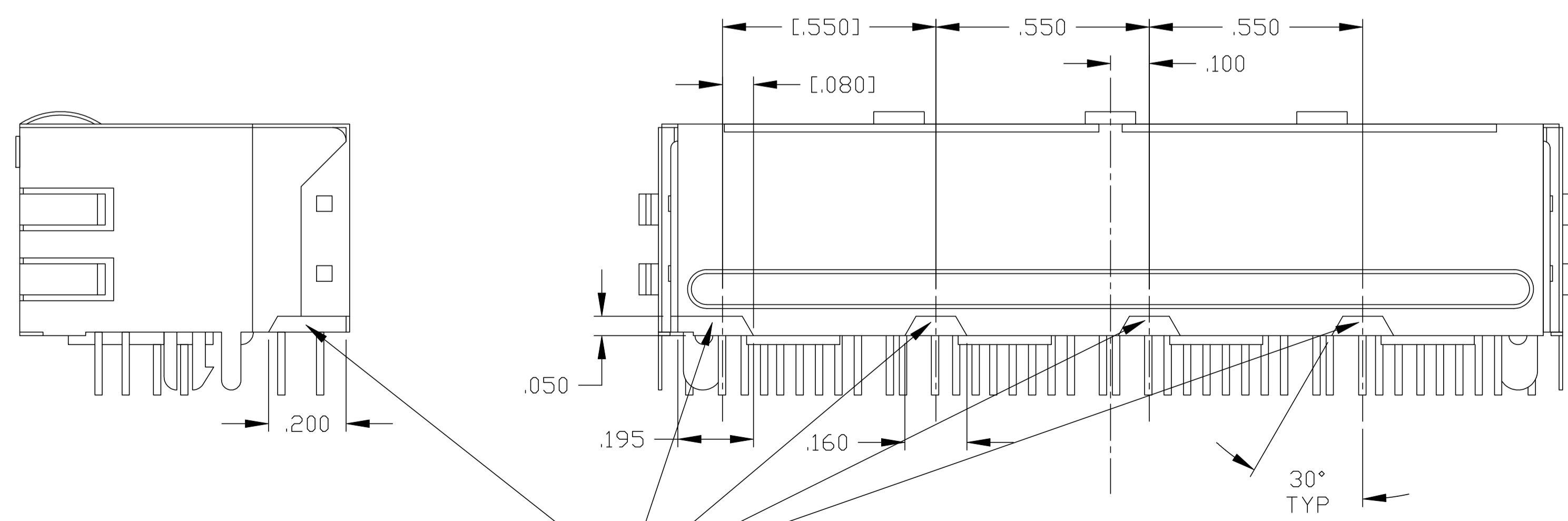
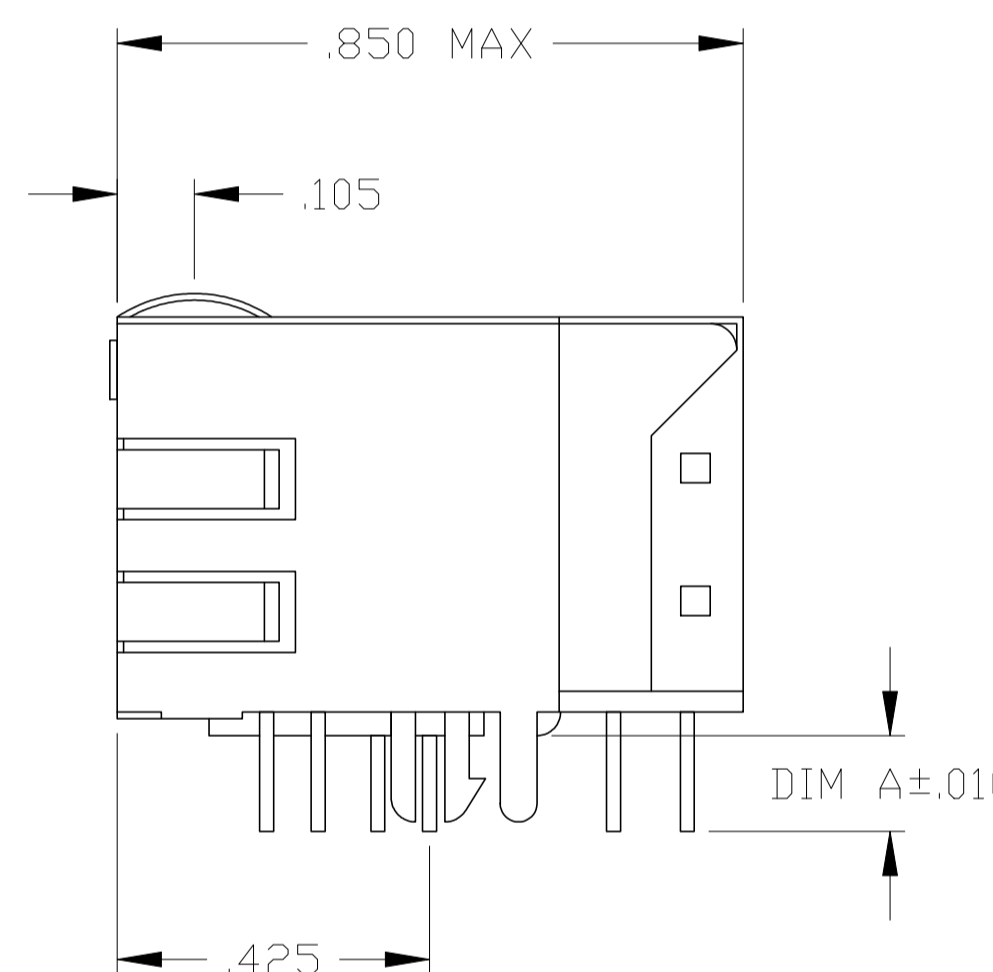
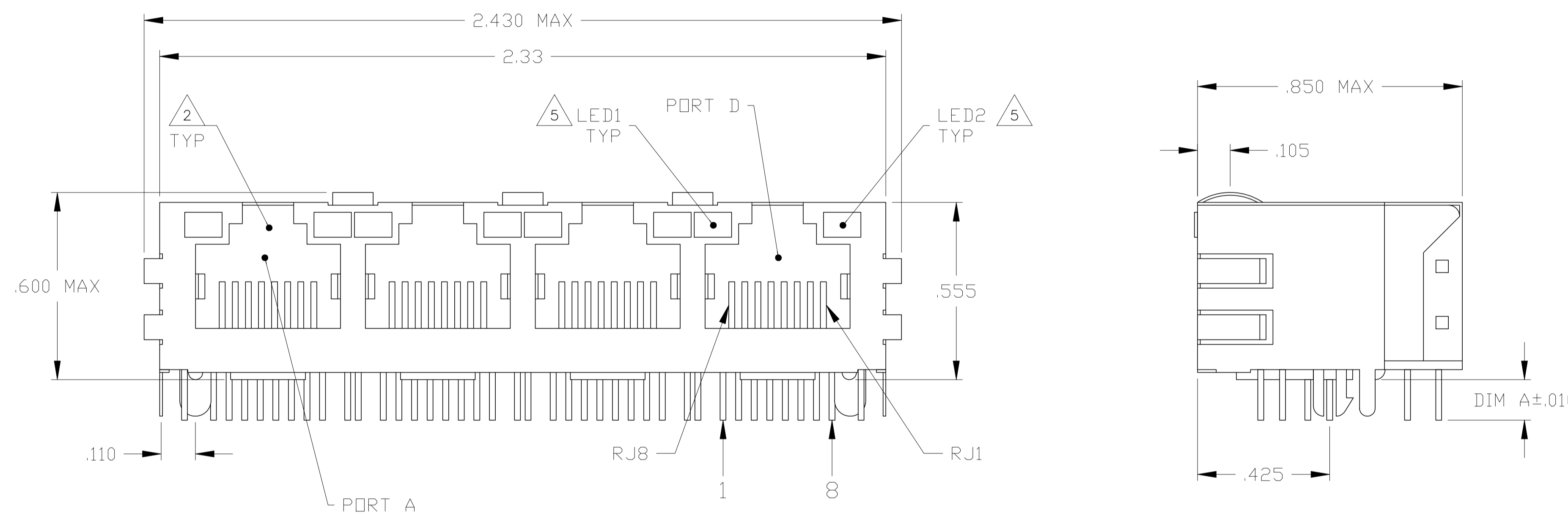
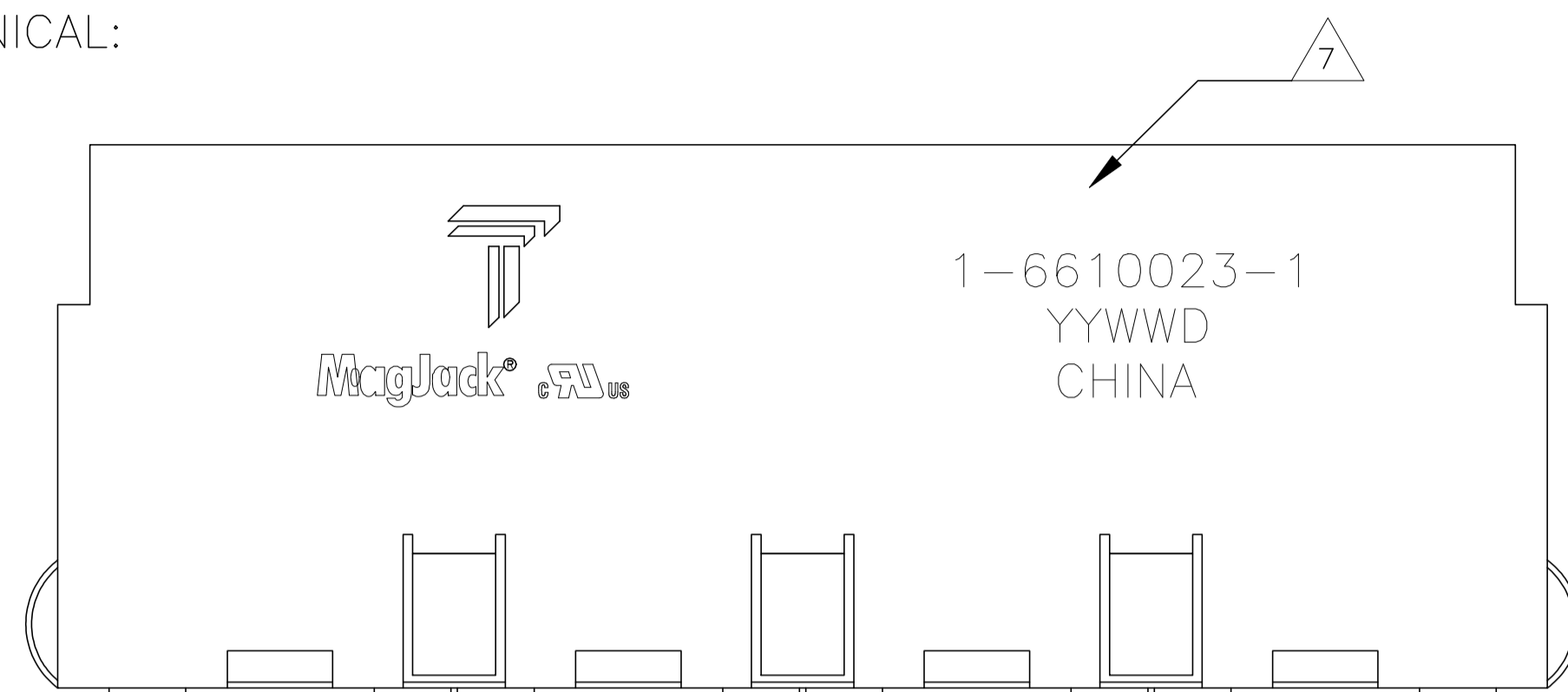

NOTCHES IN THE REAR SIDE OF SHIELD ONLY PRESENT AT 6610023-1 & 1-6610023-1

- 1 MATERIALS:
 -HOUSING - THERMOPLASTIC PET POLYESTER FLAMMABILITY RATING UL 94V-0.
 -SHIELD - 0.010" THICK, C26800 BRASS PREPLATED WITH 30μ INCH MIN SEMI-BRIGHT NICKEL. SOLDER TABS POST DIPPED WITH 100μ INCH MIN SAC SOLDER.
 -MOD JACK CONTACTS - 0.0157" X 0.018" PHOSPHOR BRONZE, 50μ INCH MIN OVERALL NICKEL UNDERPLATE WITH SELECT 50μ INCH MIN HARD GOLD FINISH PLATE. SOLDER TAILS WITH 100μ INCH MIN MATTE TIN AND/OR SAC SOLDER DIP.
 -LIGHT EMITTING DIODE(LED) - DIFFUSED EPOXY LENS, 0.020" X 0.020" CARBON STEEL WIREFRAME LEADS PRE-PLATED WITH 80μ INCH SILVER OVER 40μ INCH NICKEL UNDERPLATE OVER 40μ INCH COPPER UNDERPLATE. POST-PLATED WITH 100μ INCH MIN MATTE TIN AND/OR SAC SOLDER DIP OR PURE TIN SOLDER DIP.

- 2 RJ45 JACK CAVITY CONFORMS TO FCC RULES AND REGULATIONS PART 68, SUB PART F.

- 3 MAGNETICS
 -IMPEDANCE: 100 OHMS
 -TURNS RATIO (CHIP:CABLE): TX = 1:1, RX = 1:1
 -OPEN CIRCUIT INDUCTANCE (OCL): 350μ H MIN @100kHz, 0.1VRMS, 8mADC BIAS FROM -40°C TO +85°C, TX AND RX
 -PERFORMANCE @ 25°C:
 INSERTION LOSS (IL): 1.1dB MAX FROM 0.5MHz TO 100MHz
 RETURN LOSS (RL): 18dB MIN FROM 0.5MHz TO 30MHz
 18-20LOG(f/30)dB MIN FROM 30.1MHz TO 60MHz
 12dB MIN FROM 60.1MHz TO 80MHz
 CROSSTALK ATTENUATION: 35dB MIN FROM 0.5MHz TO 40MHz
 33-20*LOG(f/50)dB MIN FROM 40.1MHz TO 100MHz
 COMMON MODE REJECTION RATIO (CMRR): 30dB MIN FROM 0.5MHz TO 100MHz
 -ISOLATION VOLTAGE: 2250VDC (MAX) FOR 60 SECONDS WITH A RISE TIME OF 500V/SEC AND WITH ALL PORTS CONNECTED.

4. OPERATING TEMPERATURE: FROM -40°C TO +85°C.

- 5 THE LED WITH 250 OHM RESISTORS, LED IS DRIVEN WITH 5V VOLTAGE AND THE MAX OPERATING CURRENT IS 20mA.
 LED COLOR: DOMINANT WAVELENGTH(λD): GREEN 568nm TYP. At VF=5V
 FORWARD CURRENT (IF): GREEN 12 mA TYP. AT VF=5V
 DOMINANT WAVELENGTH (λD): YELLOW 588nm TYP. At VF=5V
 FORWARD CURRENT (IF): YELLOW 13 mA TYP. AT VF=5V

- 6 INDICATED CONNECTIONS ARE FOR NIC CONFIGURATION. THE MAGNETICS ARE SYMMETRICAL AND SUPPORT AUTO-MDI/MDIX.

- 7 TRP CONNECTOR LOGO, PART NUMBER, DATE CODE, COUNTRY OF ORIGIN AND AGENCY APPROVAL MARKING IN APPROXIMATE LOCATION SHOWN.

8. THESE PARTS ARE RECOMMENDED FOR WAVE SOLDERING PROCESS, PEAK WAVE SOLDERING TEMPERATURE IS 260°C MAX, 10 SECONDS MAX.

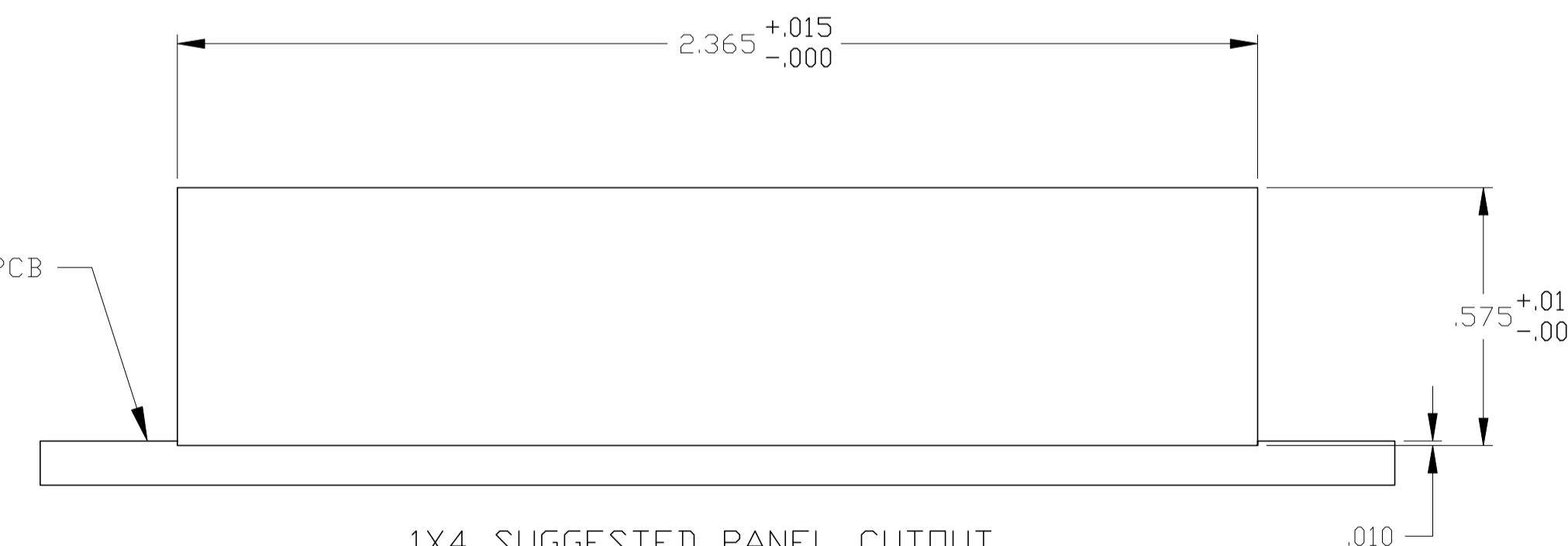

0.079	NO	YES	GREEN	YELLOW	5-6610023-2
0.145	NO	YES	GREEN	YELLOW	5-6610023-1
0.145	NO	YES	GREEN	GREEN	6-6610023-1
0.145	YES	NO	GREEN	GREEN	1-6610023-1
0.145	YES	NO	GREEN	YELLOW	6610023-1
DIM A	5 NOTCHES IN SHIELD	2KV DECOUPLING CAPACITOR	LED1	LED2	PART NUMBER

THIS DRAWING IS A CONTROLLED DOCUMENT.		DWN L. VARELA - DOCK5 15MAR2005	trp CONNECTOR		DONGGUAN CHINA
DIMENSIONS: INCHES		CHK D. FAROLE 15MAR2005	APVD D. FAROLE 15MAR2005		
TOLERANCES UNLESS OTHERWISE SPECIFIED:		MODEL NAME			
0 PLC	± .005	MAGJACK GANG			
1 PLC	± .010	NON-POE			
2 PLC	± .015	SIZE CAGE CODE DRAWING NO			
3 PLC	± .020	A1 C=6610023			
4 PLC	± .025	RESTRICTED TO			
ANGLES	± .005	CUSTOMER DRAWING			
PRODUCT SPEC 108-2100	APPLICATION SPEC	SCALE 4:1 SHEET 1 OF 2 REV G			

726ET SERIES MAGNETIC CIRCUIT

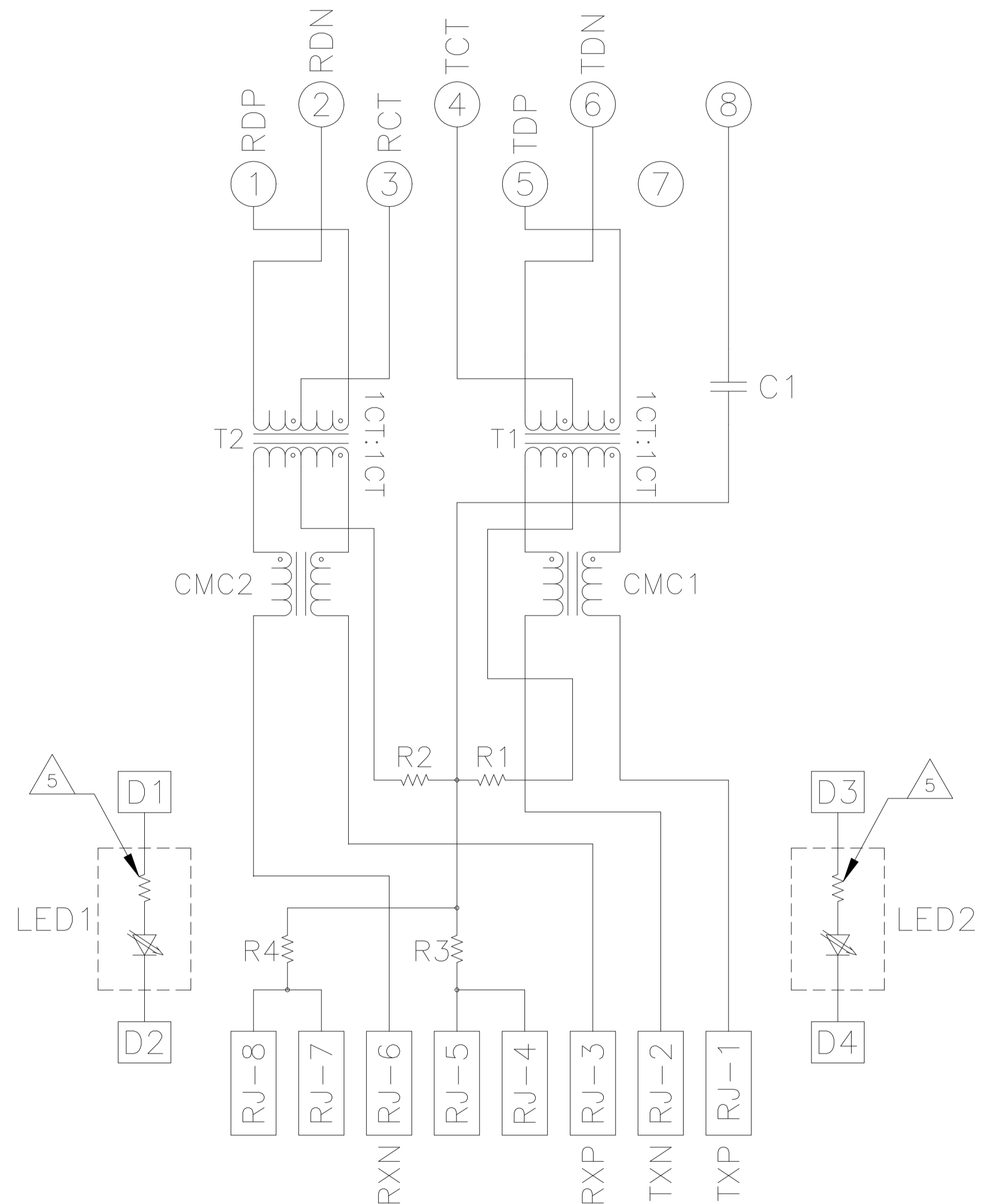

R1-R4 = 75 OHMS, 1/16W RESISTORS
 C1 = 1000 pF, 2kV CAPACITOR

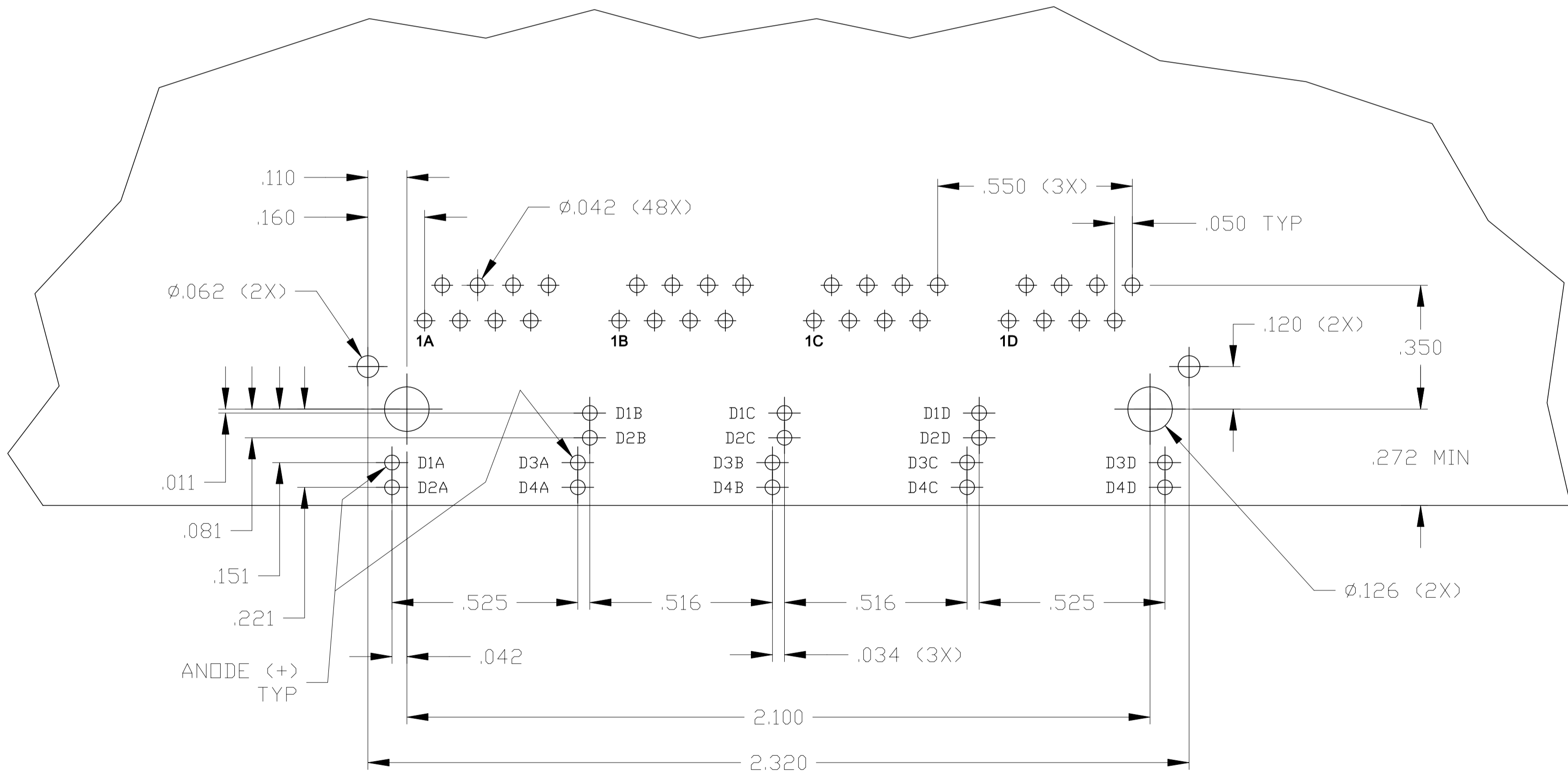
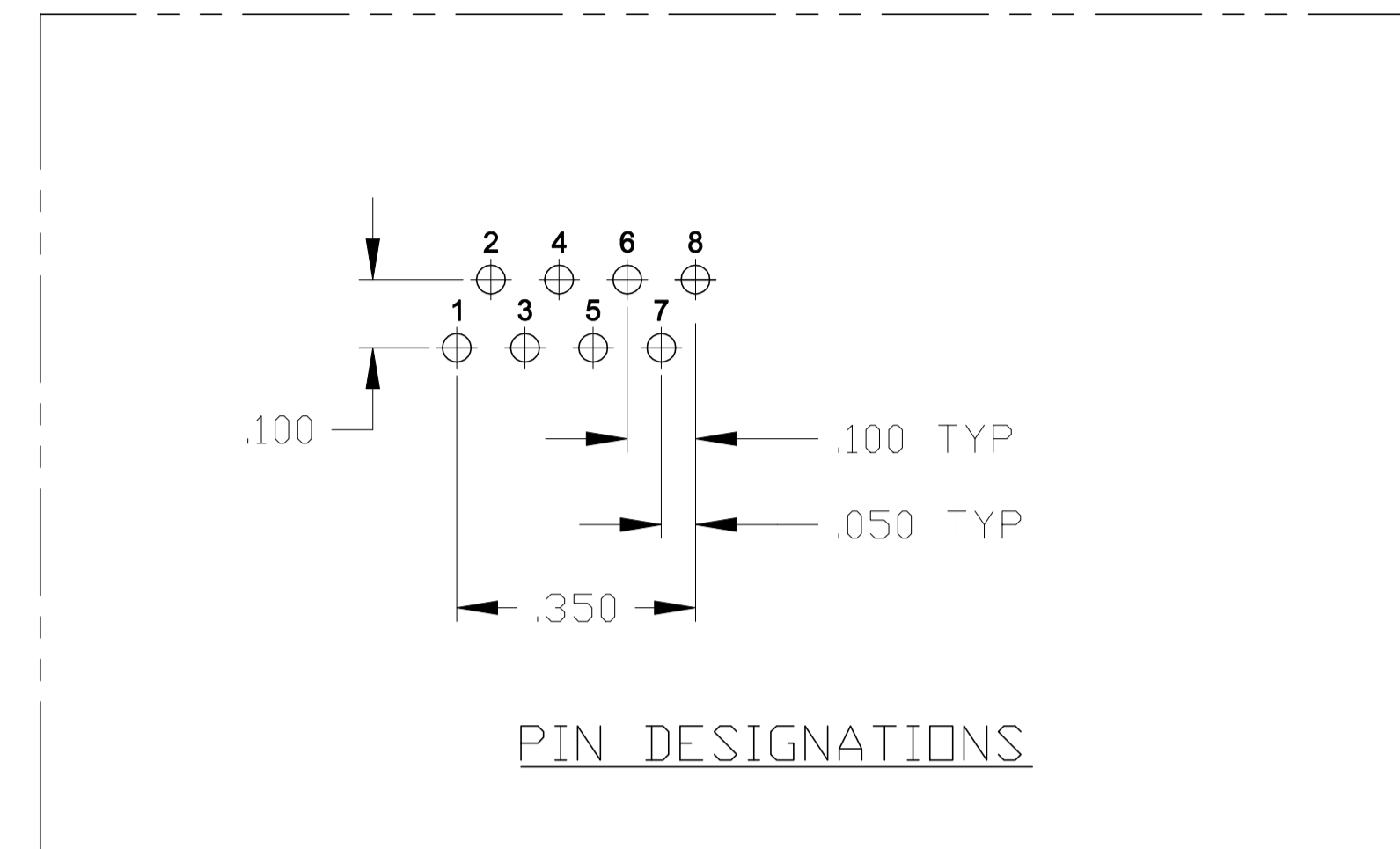

SUGGESTED PCB LAYOUT
 (Component Side)

THIS DRAWING IS A CONTROLLED DOCUMENT.		DWN L. VARELA - D0CK5 CHK D. FAROLE 15MAR2005 APVD D. FAROLE 15MAR2005		DONGGUAN CHINA	
DIMENSIONS: INCHES 		TOLERANCES UNLESS OTHERWISE SPECIFIED: 0 PLC ± - 1 PLC ± - 2 PLC ± .010 3 PLC ± .005 4 PLC ± - ANGLES ± - APPLICATION SPEC -		MODEL NAME: MAGJACK GANG NON-POE DESC: 1X4 726ET 10/100 TAB UP W/ LED SIZE: A1 CAGE CODE: - DRAWING NO: C-6610023 RESTRICTED TO: -	
PRODUCT SPEC: 108-2100		CUSTOMER DRAWING		SCALE: 4:1 SHEET 2 OF 2 REV G	