



Chipsmall Limited consists of a professional team with an average of over 10 year of expertise in the distribution of electronic components. Based in Hongkong, we have already established firm and mutual-benefit business relationships with customers from,Europe,America and south Asia,supplying obsolete and hard-to-find components to meet their specific needs.

With the principle of “Quality Parts,Customers Priority,Honest Operation,and Considerate Service”,our business mainly focus on the distribution of electronic components. Line cards we deal with include Microchip,ALPS,ROHM,Xilinx,Pulse,ON,Everlight and Freescale. Main products comprise IC,Modules,Potentiometer,IC Socket,Relay,Connector.Our parts cover such applications as commercial,industrial, and automotives areas.

We are looking forward to setting up business relationship with you and hope to provide you with the best service and solution. Let us make a better world for our industry!



Contact us

Tel: +86-755-8981 8866 Fax: +86-755-8427 6832

Email & Skype: info@chipsmall.com Web: www.chipsmall.com

Address: A1208, Overseas Decoration Building, #122 Zhenhua RD., Futian, Shenzhen, China



THIS DRAWING AND THE SUBJECT MATTER SHOWN THEREON ARE CONFIDENTIAL AND THE PROPERTY OF BEL/STEWART/TRP CONNECTOR AND SHALL NOT BE REPRODUCED, COPIED, OR USED IN ANY MANNER WITHOUT THE WRITTEN CONSENT OF TRP CONNECTOR.

PRODUCT MAY BE PROTECTED BY ONE OR MORE OF THE FOLLOWING US PATENTS:
 5736910 5939955 6425781 6428361 6554638 6840817 7123117
 7429195 7717749 7808751 6217391 6149050 7924130

REVISIONS				
P	LR	DESCRIPTION	DATE	APPD
F		EC-1411035 COMPANY LOGO CHANGE	05JAN2015	DZ TL

MECHANICAL:

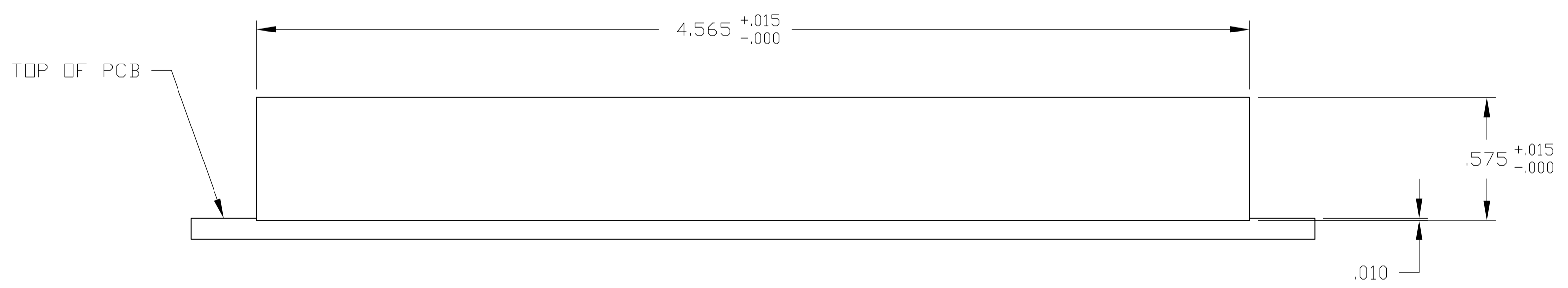
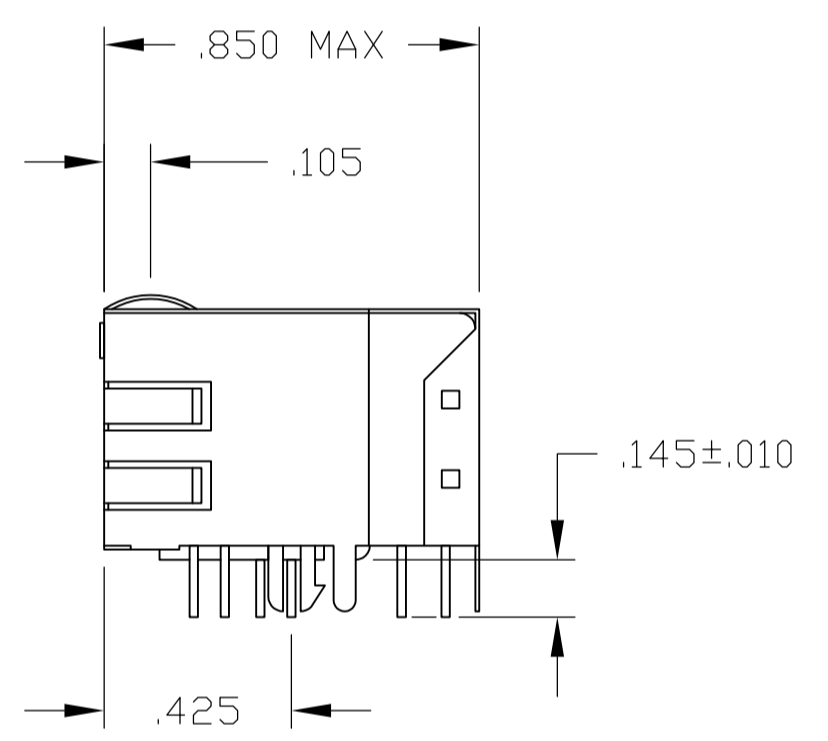
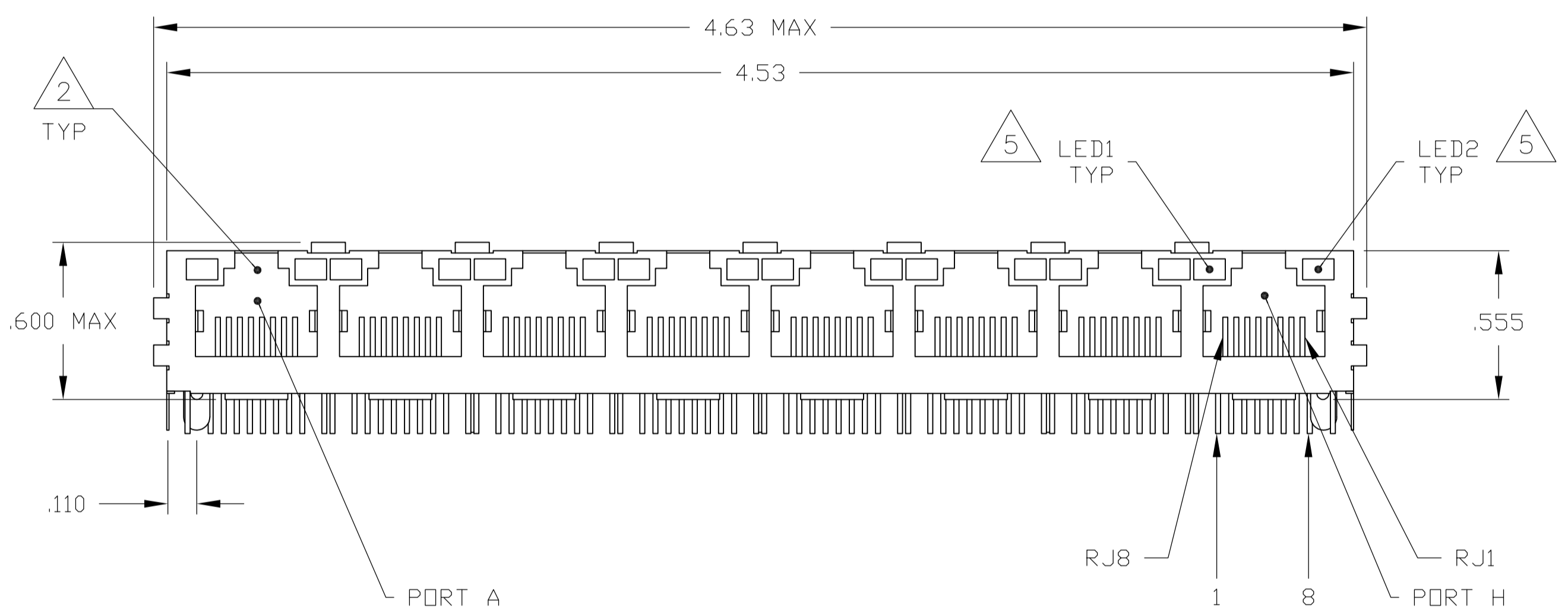
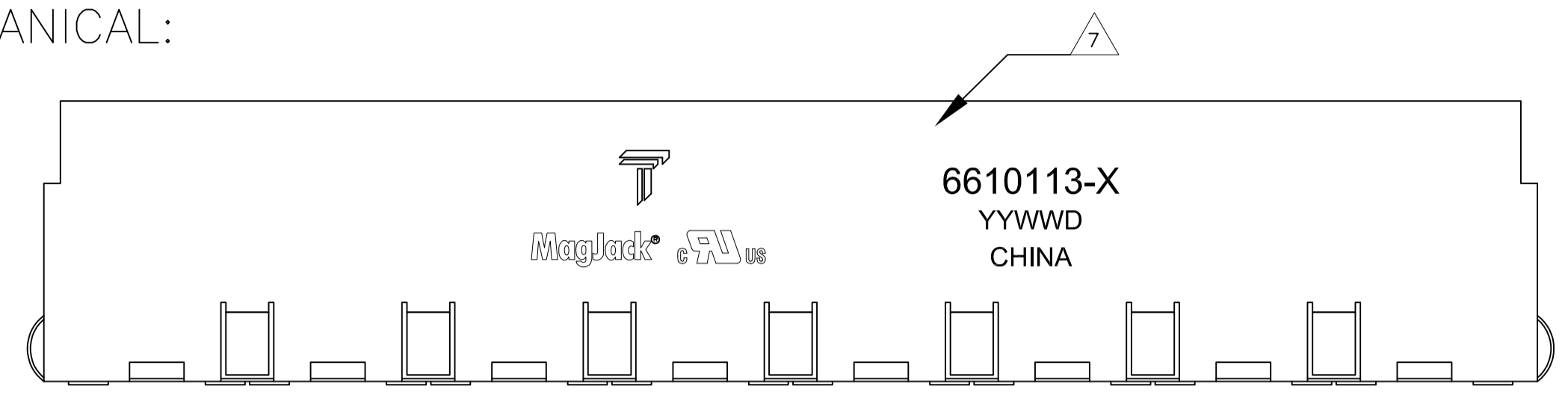

1X8 SUGGESTED PANEL CUTOUT

1. MATERIALS:
 - HOUSING - THERMOPLASTIC PET POLYESTER FLAMMABILITY RATING UL 94V-0.
 - SHIELD - .010" THICK, C26800 BRASS PREPLATED WITH 30μINCH MIN SEMI-BRIGHT NICKEL. SOLDER TABS POST DIPPED WITH 100μINCH MIN SAC SOLDER.
 - MOD JACK CONTACTS - 0.0157 X 0.018" PHOSPHOR BRONZE, 50μINCH MIN OVERALL NICKEL UNDERPLATE WITH SELECT 50μINCH MIN HARD GOLD FINISH PLATE. SOLDER TAILS WITH 100μINCH MIN MATTE TIN AND/OR SAC SOLDER DIP.
 - LIGHT EMITTING DIODE(LED) - DIFFUSED EPOXY LENS, .020" X .020" CARBON STEEL WIREFRAME LEADS PRE-PLATED WITH 80μINCH SILVER OVER 40μINCH NICKEL UNDERPLATE OVER 40μINCH COPPER UNDERPLATE. POST-PLATED WITH 100μINCH MIN MATTE TIN AND/OR SAC SOLDER DIP OR PURE TIN SOLDER DIP.
2. RJ45 JACK CAVITY CONFORMS TO FCC RULES AND REGULATIONS PART 68, SUB PART F.
3. MAGNETICS
 - APPLICATION: 10/100 BASE-T
 - IMPEDANCE: 100 OHMS
 - TURNS RATIO (CHIP-CABLE): TX = 1:1, RX = 1:1
 - OPEN CIRCUIT INDUCTANCE (OCL): 350μH MIN @100kHz, 0.1VRMS, 8mADC BIAS FROM 0°C TO 70°C, TX AND RX
 - PERFORMANCE @ 25°C:
 - INSERTION LOSS (IL): 1.1dB MAX FROM 0.5MHz TO 100MHz
 - RETURN LOSS (RL): 18dB MIN FROM 0.5MHz TO 30MHz
 - 18-20LOG(f/30)dB MIN FROM 30.1MHz TO 60MHz
 - 12dB MIN FROM 60.1MHz TO 80MHz
 - CROSSTALK ATTENUATION: 35dB MIN FROM 0.5MHz TO 40MHz
 - 33-20*LOG(f/50)dB MIN FROM 40.1MHz TO 100MHz
 - COMMON MODE REJECTION RATIO (CMRR): 30dB MIN FROM 0.5MHz TO 100MHz
 - ISOLATION VOLTAGE: 2250VDC (MAX) FOR 60 SECONDS WITH A RISE TIME OF 500V/SEC AND WITH ALL PORTS CONNECTED.
4. OPERATING TEMPERATURE: FROM 0°C TO +70°C.
5. LEDS WITH BUILT-IN RESISTOR
 - THE 250 OHM RESISTOR IS INCLUDED IN THE LEDS.
 - LEDS ARE DRIVEN WITH 5V VOLTAGE AND THE MAX OPERATING CURRENT IS 20mA.
 - LED COLOR: DOMINANT WAVELENGTH (λD): GREEN 568 nm TYP @ VF=5V
 - FORWARD CURRENT (IF): GREEN 12mA TYP @ VF=5V
 - DOMINANT WAVELENGTH (λD): YELLOW 588 nm TYP @ VF=5V
 - FORWARD CURRENT (IF): YELLOW 13mA TYP @ VF=5V
6. INDICATED CONNECTIONS ARE FOR A HUB CONFIGURATION. THE MAGNETICS ARE SYMMETRICAL AND SUPPORT AUTO-MDIX.
7. TRP CONNECTOR LOGO, PART NUMBER, DATE CODE, COUNTRY OF ORIGIN AND AGENCY APPROVAL MARKING IN APPROXIMATE LOCATION SHOWN.
8. THE PART IS RECOMMENDED FOR WAVE SOLDERING PROCESS, PREHEAT TEMPERATURE IS 120°C TO 160°C, 120 SECONDS TO 180 SECONDS, PEAK WAVE SOLDERING TEMPERATURE IS 260°C MAX, 10 SECONDS MAX.

GREEN	YELLOW	5-6610113-1
LED1	LED2	PART NUMBER

THIS DRAWING IS A CONTROLLED DOCUMENT.		DWN: A. FERNANDEZ 16MAR2005 CHK: D. FAROLE 16MAR2005 APD: D. FAROLE 16MAR2005		TRP CONNECTOR a bel group DONGGUAN CHINA	
DIMENSIONS: INCHES 0 PLC ± - 1 PLC ± - 2 PLC ± .010 3 PLC ± .005 4 PLC ± - ANGLES ± - APPLICATION SPEC: -		MODEL NAME: MAG-JACK GANG NON-POE		DESC: 1X8 766K1 10/100 TAB UP W/ LED SIZE: A1 CAGE CODE: - DRAWING NO: C-6610113 RESTRICTED TO: -	
PRODUCT SPEC: 108-2100		CUSTOMER DRAWING		SCALE: NTS SHEET 1 OF 2 REV F	

