



Chipsmall Limited consists of a professional team with an average of over 10 year of expertise in the distribution of electronic components. Based in Hongkong, we have already established firm and mutual-benefit business relationships with customers from,Europe,America and south Asia,supplying obsolete and hard-to-find components to meet their specific needs.

With the principle of “Quality Parts,Customers Priority,Honest Operation,and Considerate Service”,our business mainly focus on the distribution of electronic components. Line cards we deal with include Microchip,ALPS,ROHM,Xilinx,Pulse,ON,Everlight and Freescale. Main products comprise IC,Modules,Potentiometer,IC Socket,Relay,Connector.Our parts cover such applications as commercial,industrial, and automotives areas.

We are looking forward to setting up business relationship with you and hope to provide you with the best service and solution. Let us make a better world for our industry!



Contact us

Tel: +86-755-8981 8866 Fax: +86-755-8427 6832

Email & Skype: info@chipsmall.com Web: www.chipsmall.com

Address: A1208, Overseas Decoration Building, #122 Zhenhua RD., Futian, Shenzhen, China



Operating Temperature Range

-25° to 70° C , relative humidity of 85% or less

Materials

1. Insulator: POM, black
2. Shell: C3604 brass, 2 µm nickel plated
3. Spring contact: C5191 phosphor bronze, 2 µm nickel plated
4. Spring fork: C5191 phosphor bronze, 1 µ" gold plated
5. Spring fork: C5191 phosphor bronze, 2 µm nickel plated

Electrical Requirements

Dielectric strength: 1 min @ 500 Vac
 Insulation resistance: 100 MΩ @ 500 Vdc
 Contact resistance: 50 mΩ or less

Mechanical Requirements

Insertion force: 0.4-4 kgf
 Withdrawal force: 0.4-4 kgf
 Life cycle: 5000 mating cycles while maintaining 0.3 kgf min. insertion force, 0.3 kgf min. withdrawal force and less than 60 mΩ contact resistance.

Environmental Requirements

Heat test: 70 °C, relative humidity 70-85% for 96 hours without deformation
 Humidity test: 40 °C, relative humidity 90-100% for 96 hours without deformation
 Salt spray test: 35±2 °C, relative humidity 90-95%, 5% NaCl mist for 24 hrs. Wash parts after test. Maintain mechanical requirements and a contact resistance of less than 100 mΩ.

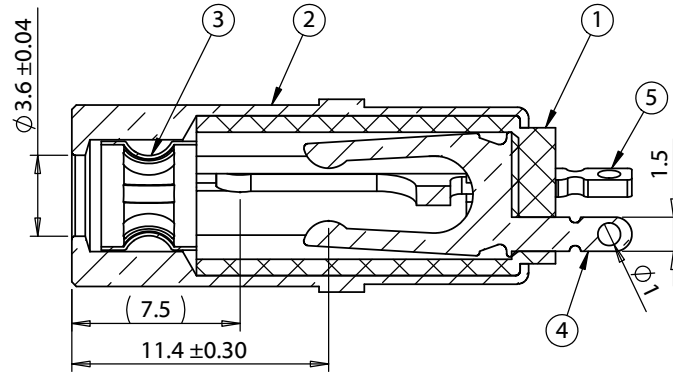

SECTION A-A
SCALE 3 : 1

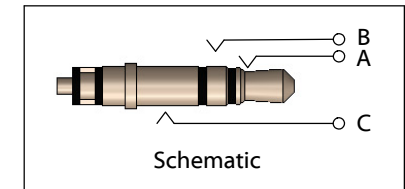
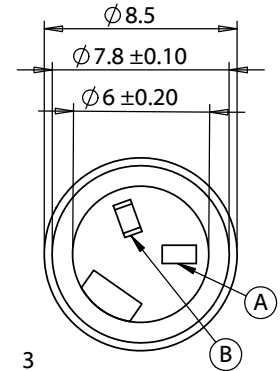
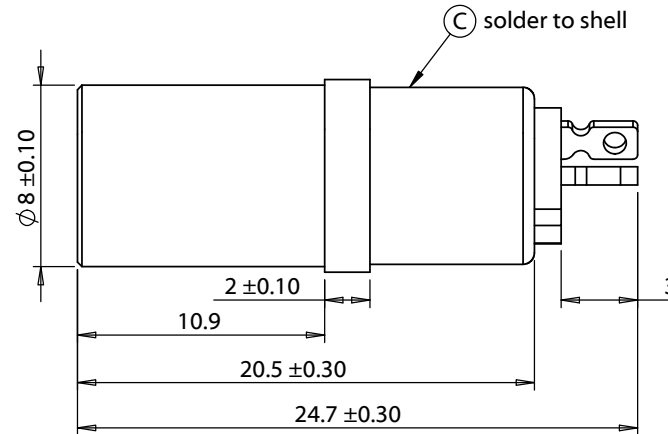
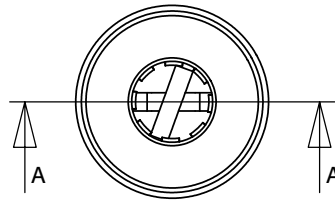

Revision:	Date:	Description:	Prepared: GL 2016.08.15 16:03:51 -07'00'	Notes:	<h1>TENSILITY</h1> tel 1.541.323.3228 800 877.670.7118 fax 1.541.323.4202 web tensility.com
A	9/4/2009	Initial release	Verified: PS <small>Digitally signed by PS Date: 2016.08.15 16:58:51 -07'00'</small>	RoHS and REACH compliant	
A1	6/6/2012	Updated drawing	Dimensions are in millimeters. Tolerances: X: ± 0.5 mm X.X: ± 0.3 mm X.XX: ± 0.05 mm	Function test: no open, no short circuit, no intermittent	Size: Part number: A 50-00039
				Description: Connector, stereo jack, 3.5x8.0xL24.7 mm, brass, nickel plated, molding style	Scale: 5:1 Sheet 1 of 1