



Chipsmall Limited consists of a professional team with an average of over 10 year of expertise in the distribution of electronic components. Based in Hongkong, we have already established firm and mutual-benefit business relationships with customers from,Europe,America and south Asia,supplying obsolete and hard-to-find components to meet their specific needs.

With the principle of “Quality Parts,Customers Priority,Honest Operation,and Considerate Service”,our business mainly focus on the distribution of electronic components. Line cards we deal with include Microchip,ALPS,ROHM,Xilinx,Pulse,ON,Everlight and Freescale. Main products comprise IC,Modules,Potentiometer,IC Socket,Relay,Connector.Our parts cover such applications as commercial,industrial, and automotives areas.

We are looking forward to setting up business relationship with you and hope to provide you with the best service and solution. Let us make a better world for our industry!



Contact us

Tel: +86-755-8981 8866 Fax: +86-755-8427 6832

Email & Skype: info@chipsmall.com Web: www.chipsmall.com

Address: A1208, Overseas Decoration Building, #122 Zhenhua RD., Futian, Shenzhen, China



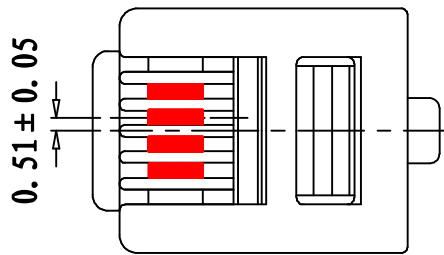

MP6P4C

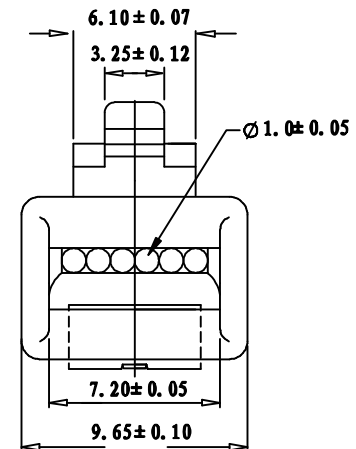
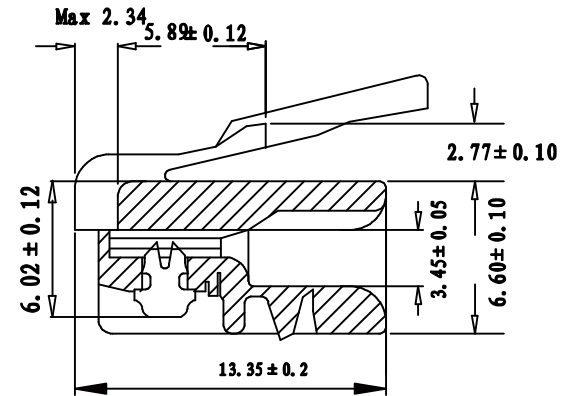
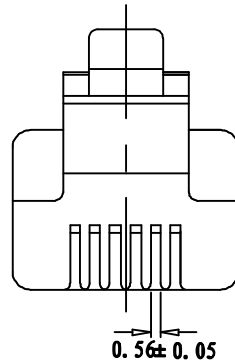

SPECIFICATIONS

HOUSING	POLY CARBONATE (PC) UL94V2 NO. E919153
CONTACT BLADE	HIGH STRENGTH COPPER ALLLOY
MATERIAL	100 MICRON NICKEL UNDERPLATED
PLATING TYPE	8% PHOSPHOR BRONZE
PLATING THICKNESS:	GOLD PLATED FU"
OPERATING TEMP	-40° C TO 125° C
CURRENT RATING	250V AC MAX AT 2A
DIELECTRIC	500V AC
INSULATION RES	500MGAOHMS
COMPLIES WITH FCC68/F	

"RoHS Compliance"

REVISE	VERSION	LT#	CONTENTS
12-02-23	A/0	T0222B	NEW DRAWING

CnC Tech, LLC Industrial Cable and Connector Technology		
REV.NO:	ISSUE (A/0)	CUSTOMER:L-671
DRAWING NO:	671-375-FU-001	PART NO:5010-FU0064-001
ITEM NO:	MP6P4C PLUG(F)	
UNIT:MM	DRAWN:	ENGINEER:
DATE:12-02-23	QA:	SALES DEPT:
		SALES MANAGER: