



Chipsmall Limited consists of a professional team with an average of over 10 year of expertise in the distribution of electronic components. Based in Hongkong, we have already established firm and mutual-benefit business relationships with customers from,Europe,America and south Asia,supplying obsolete and hard-to-find components to meet their specific needs.

With the principle of "Quality Parts,Customers Priority,Honest Operation,and Considerate Service",our business mainly focus on the distribution of electronic components. Line cards we deal with include Microchip,ALPS,ROHM,Xilinx,Pulse,ON,Everlight and Freescale. Main products comprise IC,Modules,Potentiometer,IC Socket,Relay,Connector.Our parts cover such applications as commercial,industrial, and automotives areas.

We are looking forward to setting up business relationship with you and hope to provide you with the best service and solution. Let us make a better world for our industry!



Contact us

Tel: +86-755-8981 8866 Fax: +86-755-8427 6832

Email & Skype: info@chipsmall.com Web: www.chipsmall.com

Address: A1208, Overseas Decoration Building, #122 Zhenhua RD., Futian, Shenzhen, China



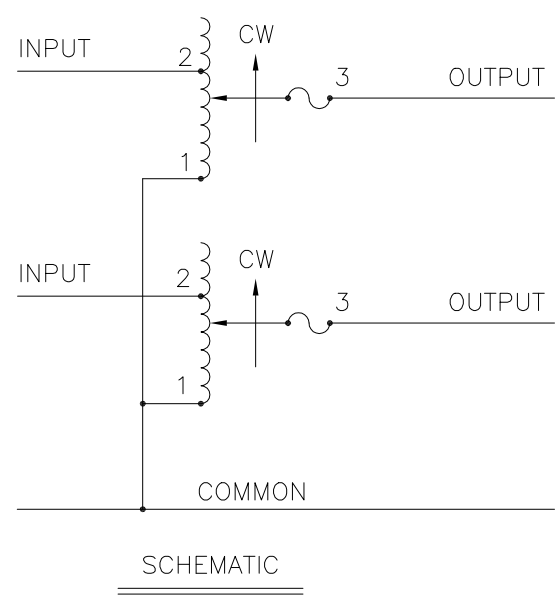
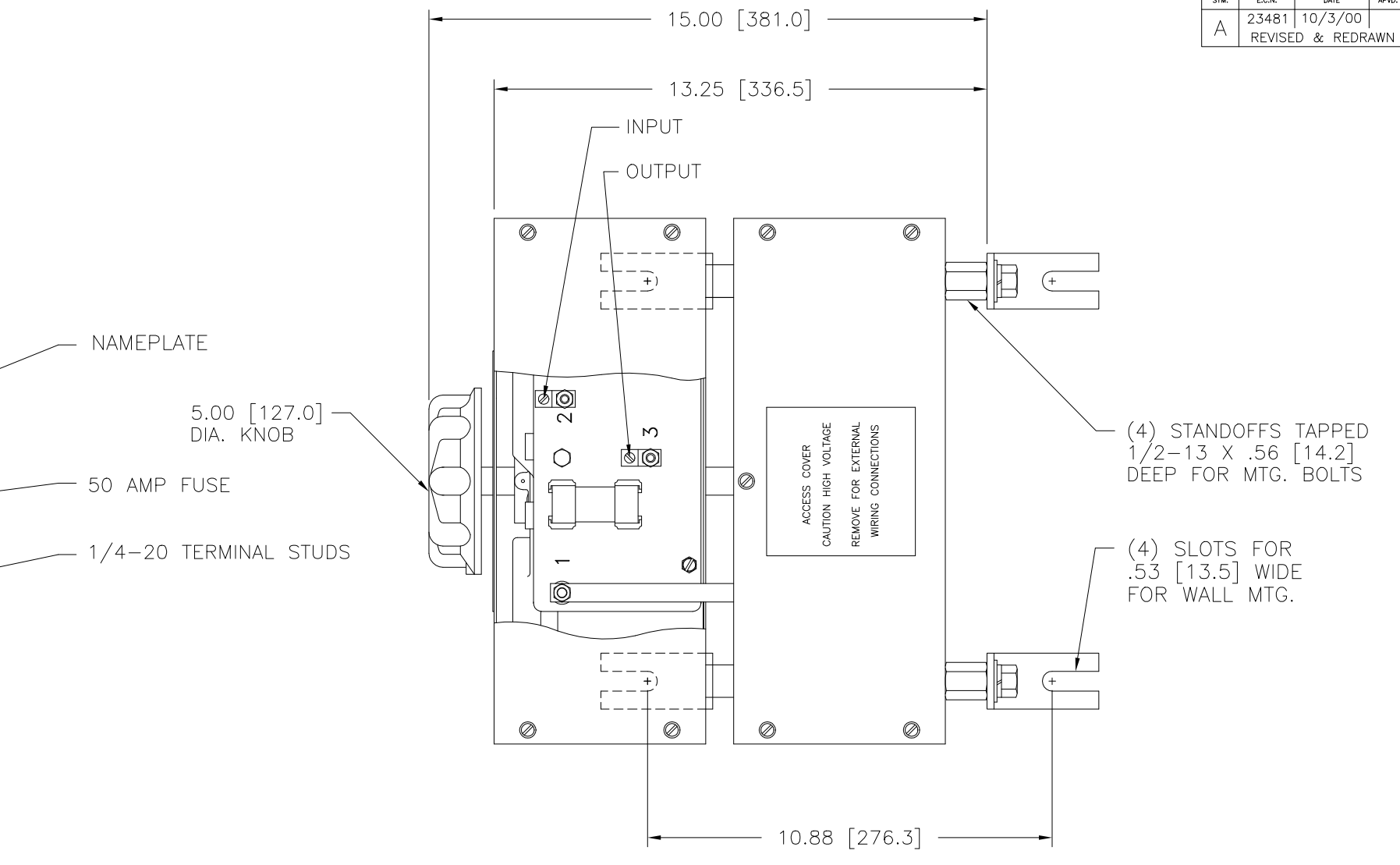
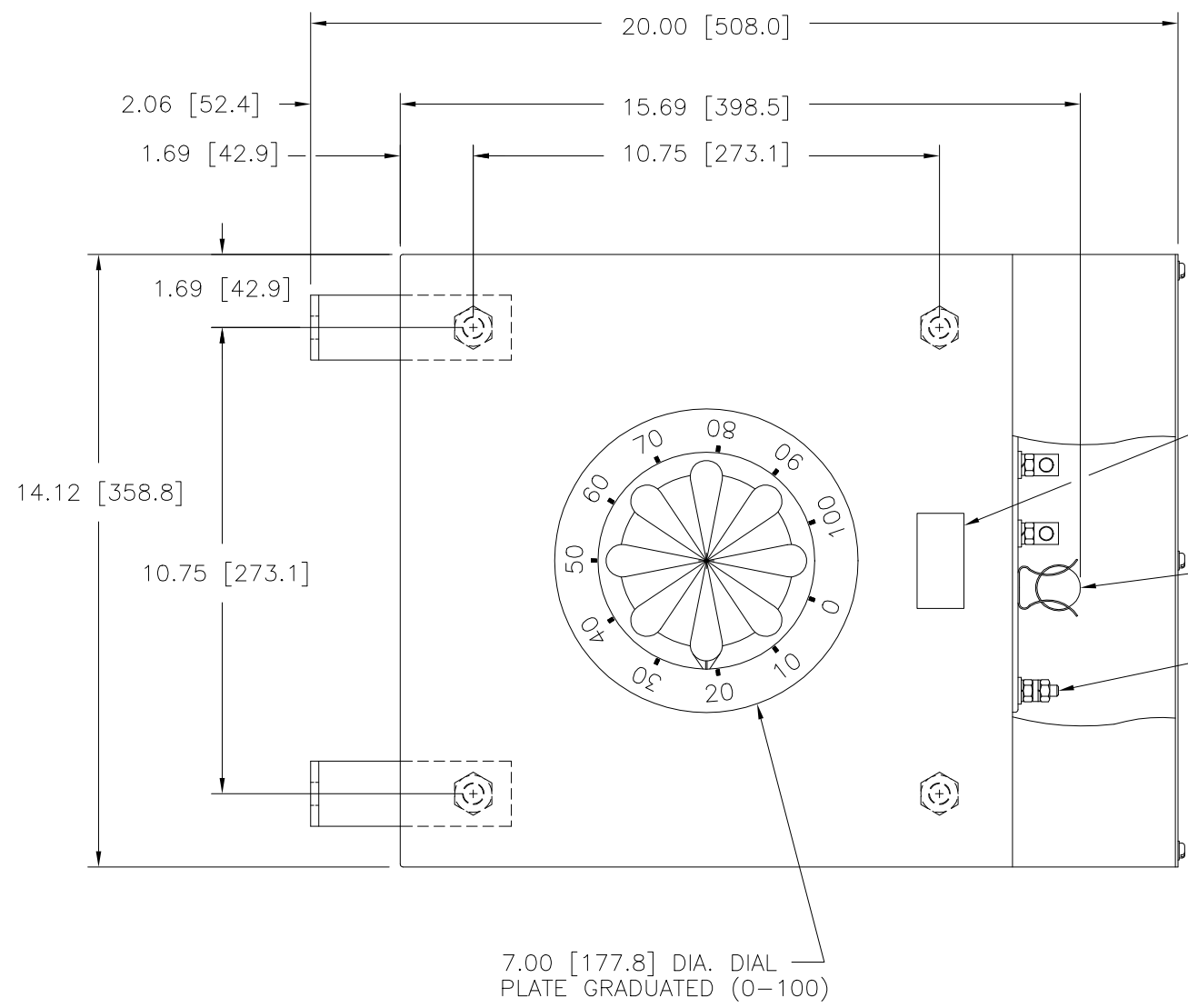

SPECIFICATIONS								
WIRING	INPUT		OUTPUT			SHAFT ROTATION TO INCREASE VOLTAGE	TERMINAL CONNECTIONS FOR INCREASING VOLTAGE AS VIEWED FROM ROTOR END	
	VOLTS	HERTZ	VOLTS	MAX. AMPS	MAX. KVA		INPUT	OUTPUT
SINGLE PHASE SERIES	240	50/60	0-280	50	14.0	CW	2-2	3-3

UNLESS OTHERWISE SPECIFIED, TOLERANCE IS # DECIMALS .005 Holes .002 ANGLES 1° DRAFT 1-1/2° UNITS IN [mm] TITLE: SPEC. CONTROL DWG. VARIABLE TRANSFORMER TYPE: 5011CT-2S

MATERIAL: ALL DIMENSIONS APPLY AFTER PLATING

STACO ENERGY PRODUCTS CO. A COMPONENTS CORPORATION OF AMERICA COMPANY DAYTON, OHIO U.S.A.

DRAWN BY: F. SEALE DATE: 9/12/96 FIRST USED ON: DO NOT SCALE DWG. CUSTOMER APPROVAL: DATE: CHECKER: DATE: WEIGHT APPROX.: CODE IDENT. NO. 83008 DWG. NO. 031-6031 ENGINEER: DATE: SCALE: .5=1 SHEET 1 OF 1