



Chipsmall Limited consists of a professional team with an average of over 10 year of expertise in the distribution of electronic components. Based in Hongkong, we have already established firm and mutual-benefit business relationships with customers from,Europe,America and south Asia,supplying obsolete and hard-to-find components to meet their specific needs.

With the principle of “Quality Parts,Customers Priority,Honest Operation,and Considerate Service”,our business mainly focus on the distribution of electronic components. Line cards we deal with include Microchip,ALPS,ROHM,Xilinx,Pulse,ON,Everlight and Freescale. Main products comprise IC,Modules,Potentiometer,IC Socket,Relay,Connector.Our parts cover such applications as commercial,industrial, and automotives areas.

We are looking forward to setting up business relationship with you and hope to provide you with the best service and solution. Let us make a better world for our industry!



## Contact us

Tel: +86-755-8981 8866 Fax: +86-755-8427 6832

Email & Skype: info@chipsmall.com Web: www.chipsmall.com

Address: A1208, Overseas Decoration Building, #122 Zhenhua RD., Futian, Shenzhen, China



## Zero Volt Monitor Installation, Operation and Maintenance

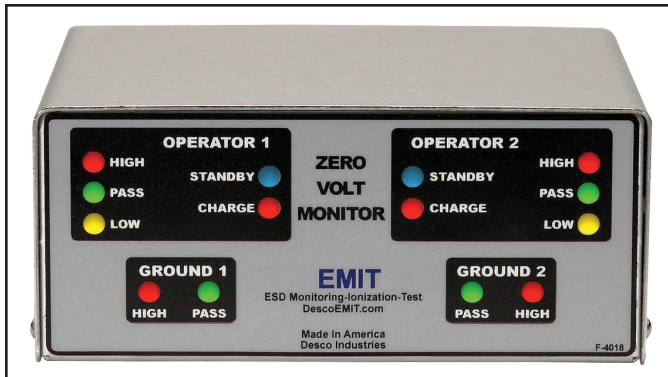

Figure 1. EMIT Zero Volt Monitor

### Description

The patented\* EMIT Zero Volt Monitor provides continuous ground monitoring of two operators and their worksurfaces using ZERO VOLT MONITORING™ resistive loop technology. No other method is as direct and reliable. This technology allows the operator to typically be near zero volts with respect to equipment ground. The Zero Volt Monitor is also unaffected by capacitance variations associated with personnel and environmental conditions.

Continuous Monitors pay for themselves improving quality, productivity, eliminating wrist strap daily testing and test result logging. Per ANSI/ESD S1.1 section 6.1.3 Frequency of Functional Testing “The wrist strap system should be tested daily to ensure proper electrical value. Daily testing may be omitted if constant monitoring is used.” Per ESD Handbook ESD TR20.20 section 5.3.2.4.4 “Typical Test programs recommend that wrist straps that are used daily should be tested daily. However, if the products that are being produced are of such value that knowledge of a continuous, reliable ground is needed, and then continuous monitoring should be considered or even required.”

The Zero Volt Monitor is available in the following models:

Item	Power Adapter	Wrist Strap Kit
50528	N. America	<a href="#">19690</a>
50537	None	<a href="#">19690</a>
50538	N. America	<a href="#">09163</a>

### EMIT SIM Software

The EMIT Zero Volt Monitor is compatible with EMIT SIM Software. EMIT SIM provides a platform to monitor and record the activity of your EMIT Smart Products. Save costs by using EMIT SIM to eliminate the need to rely on people to physically check the status of continuous monitors and ionizers every day. This software also features tools for generating activity reports and calibration / maintenance schedule management.



[Click here](#) to learn more.

### Packaging

- 1 Zero Volt Monitor
- 1 Snap Kit
- 1 Power Adapter (50528, 50538 only)
- 2 Wrist Strap Kits
- 2 Operator Cables (black and white)
- 2 Mat Cords (black and white)
- 1 Monitor Ground Cord (green)
- 2 Mat Ground Cords (green)

### Features and Components

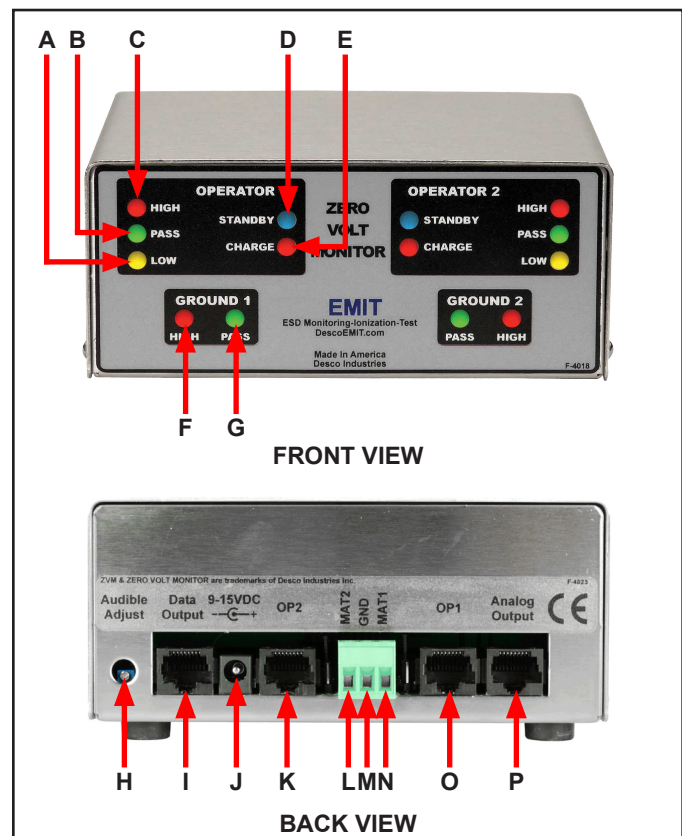

Figure 2. Zero Volt Monitor features and components

\*US patents 6,052,053 and 6,205,408

**A. Operator Fail Low LED:** Illuminates and alarm sounds when the operator's resistance is below the test limit.

**B. Operator Pass LED:** Illuminates when the operator is properly grounded.

**C. Operator Fail High LED:** Illuminates and alarm sounds when the operator's resistance is above the test limit.

**D. Operator Standby LED:** Illuminates when the operator is not connected to the remote.

**E. Operator Charge LED:** Illuminates and alarm sounds when the charge on the operator is greater than  $\pm 1.25V$ .

**F. Mat Fail LED:** Illuminates and alarm sounds when the worksurface mat is not properly grounded.

**G. Mat Fail LED:** Illuminates when the worksurface mat is properly grounded.

**H. Alarm Audible Adjustment:** Turn the trimpot clockwise to increase the audible alarm volume and counter-clockwise to decrease it.

**I. Data Output:** To be used with the EMIT Smart Hub and EMIT SIM Software for real time data acquisition.

**J. Power Jack:** Connect a 9-15VDC power adapter here.

**K. Operator 2 Remote Jack:** Connect the black operator remote cable here.

**L. Mat 2 Terminal:** Monitors worksurface mat #2. Connect the black mat cord here.

**M. Monitor Ground Terminal:** Common ground point for the monitor. Connect the black monitor ground cord here

**N. Mat 1 Terminal:** Monitors worksurface mat #1. Connect the white mat cord here.

**O. Operator 1 Remote Jack:** Connect the white operator remote cable here.

**P. Analog Output:** Used for troubleshooting purposes by the manufacturer.

## Installation

1. Determine the mounting location of the Zero Volt Monitor. The front panel should be visible to both operators.
2. Determine the mounting locations of the operator remotes. Be sure to install the remotes at a distance that enables its leads to reach the back of the monitor.  
  
NOTE: The operator remotes for the Zero Volt Monitor are configured differently from other EMIT remotes. Be sure to only use the remotes that were packaged with your monitor.
3. Install tinned wire ends of the mat cords to their appropriate screw terminal block located at the back of the monitor.
4. Attach the worksurface mats to ground using the green mat ground cords. Install the ring terminal end of the cord to an appropriate ground point. Attach the snaps terminals to the snaps on the worksurface mat.
5. Install the tinned wire end of the black monitor ground cord to the ground terminal located at the back of the monitor. Install its ring terminal to an appropriate ground point. Be sure to use a different ground point than the one used for the mats. The face plate screw of a grounded AC wall outlet may provide a convenient connection point.
6. Route the mat cords from the back of the monitor to the snaps on worksurface mats. The white cord is for worksurface mat #1. The black cord is for worksurface mat #2.
7. Insert the operator remote cables into their appropriate jacks located at the back of the monitor. The white cable is for operator #1. The black cable is for operator #2.
8. Connect the power adapter to the power jack located at the back of the monitor. Plug the power adapter into a proper AC power outlet. The monitor is now powered.

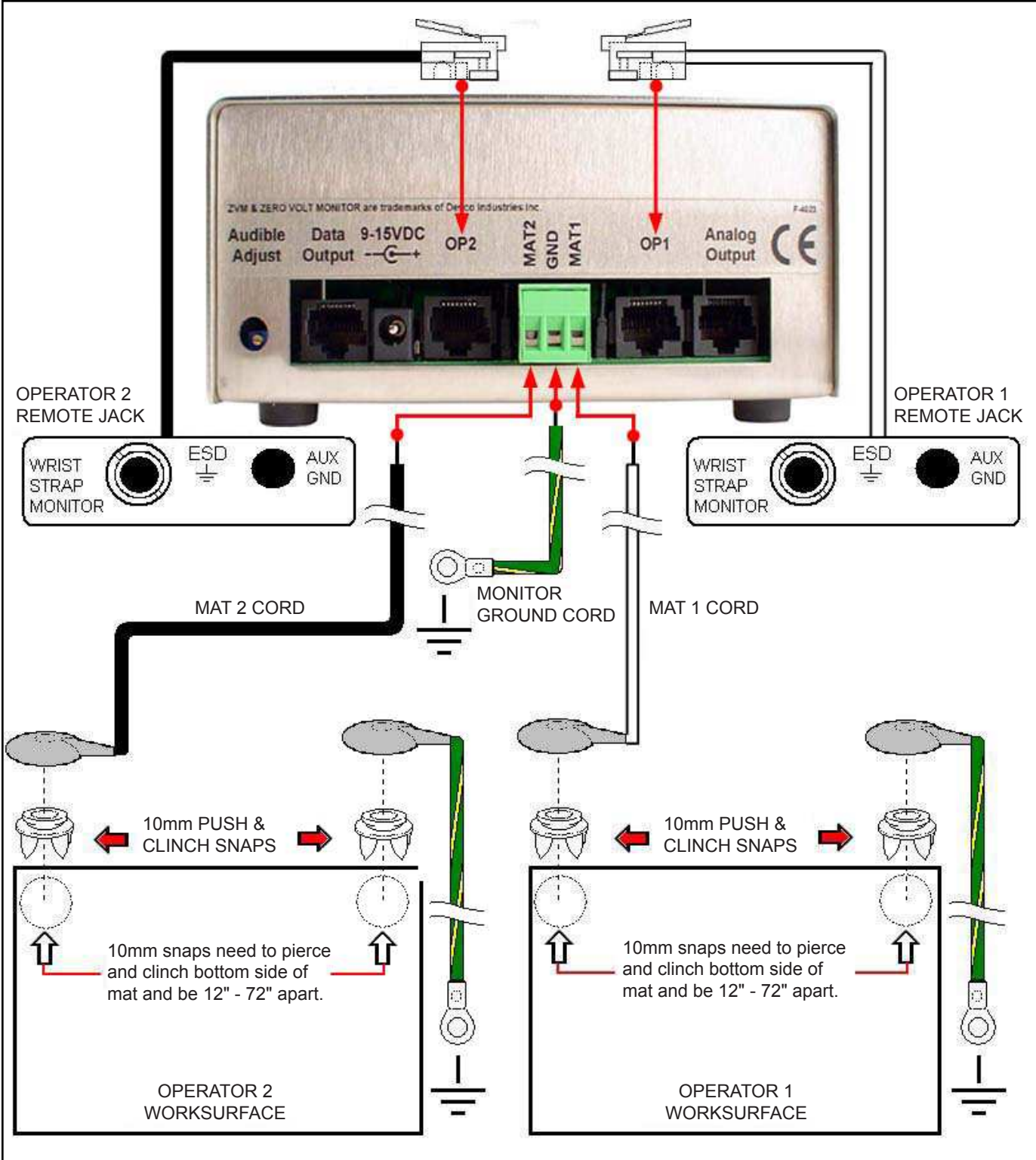

Figure 3. Installing the Zero Volt Monitor

## Operation

1. Monitoring of the operators will remain in the STANDBY condition until a wrist cord is plugged into the operator remote.
2. Plug a wrist strap cord, not attached to the wristband, into the monitored jack labeled WRIST STRAP MONITOR located on the remote. This automatically activates the selected operator channel. The corresponding operator LED should illuminate red and the alarm should sound on the monitor.
3. Remove the charges from your body by making contact with a properly grounded ESD worksurface. Snap the cord to the wristband, and fit it snugly onto your wrist. This should silence the audible alarm and cause the corresponding operator LED to switch from red to green. If this does not happen, examine the wrist cord for continuity or damage and your wrist band to ensure that it is securely fit. If you have dry skin, apply an approved dissipative hand lotion such as Menda Reztore™ ESD Hand Lotion.
4. The AUX MAT jack located on the operator remote is a grounded and unmonitored connection for guests. It must be used with a banana plug wrist cord and single-wire wristband.

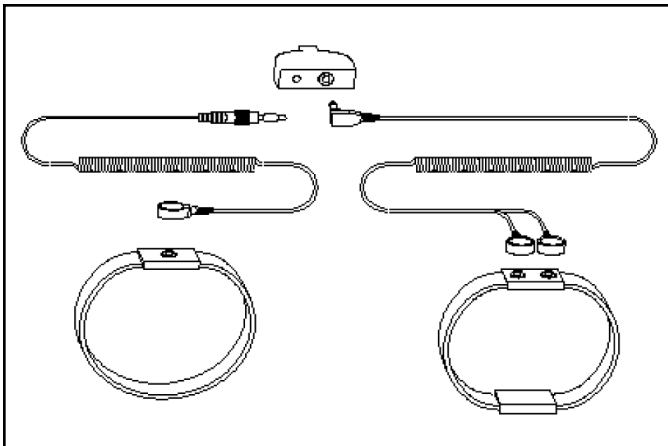

Figure 4. Connecting wrist straps to the operator remote

## CHARGE DETECTION

The CHARGE LED illuminates and the alarm sounds when the charge on the operator is greater than  $\pm 1.25V$ . To disable charge detection on the display, shunt jumper JP6 inside the unit. If a charge is detected while using this configuration, the display will remain in its previous state until the charge is no longer detected.

## Maintenance

### JUMPER SETTINGS

Feature	Enable	Disable
Audible Adjust	JP5 - OFF	JP5 - ON
Charge Display	JP6 - OFF	JP6 - ON
Data Output	JP7 - ON	JP7 - OFF

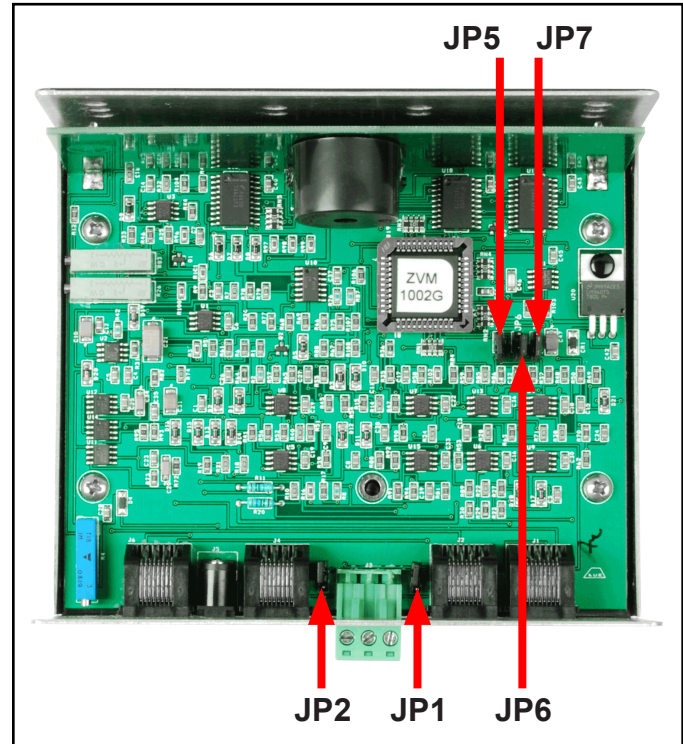

Figure 5. Jumper locations

## Calibration

The Zero Volt Monitor is calibrated to standards traceable to NIST. Frequency of recalibration should be based on the critical nature of those ESD sensitive items handled and the risk of failure for the ESD protective equipment and materials. In general, we recommend that calibration be performed annually.

Use the EMIT 50524 Limit Comparator for Dual-Wire Monitors to perform periodic testing (once every 6-12 months) of the Zero Volt Monitor. The Limit Comparator can be used on the shop floor within a few minutes virtually eliminating downtime, verifying that the monitor is operating within tolerances.

See [TB-6542](#) for more information.



Figure 6. EMIT 50524 Limit Comparator for Dual-Wire Monitors

NOTE: The series "test" resistance is not the same as the operator to ground resistance. As shown in Figure 6, the series resistance is made up of the 1 megohm resistor in the cord, the wristband to operator's skin resistance (skin contact resistance) and the operator's resistance (human body resistance).

For a given series resistance, the typical operator to ground resistance can be calculated from the following formula:

$$R_{\text{operator to ground}} = \frac{(R_{\text{series}} + 2 \text{ megohms})}{4}$$

For a given operator to ground resistance, the series resistance can be calculated from the following formula:

$$R_{\text{series}} = (R_{\text{operator to ground}} \times 4) - 2 \text{ megohms}$$

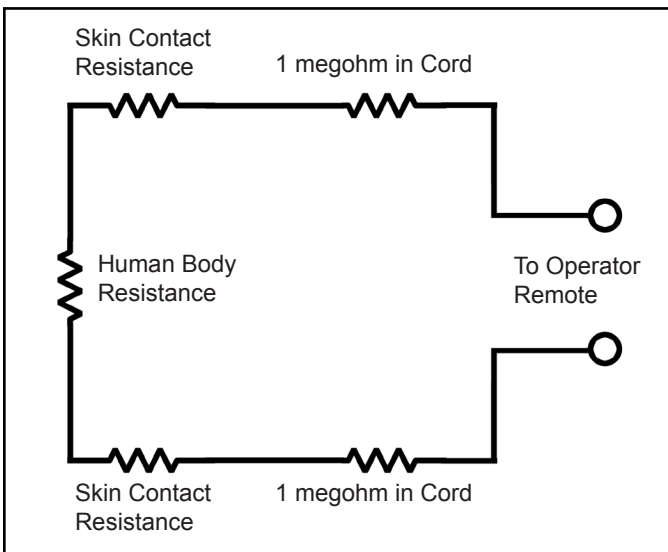

Figure 7. Operator series resistance

## MAT RESISTANCE SETTINGS

### 3.5M

1. If the desired resistance is 3.5M, jumpers JP1 (MAT 1) and JP2 (MAT 2) need to be on one pin (see Figure 5).
2. The respective potentiometers need to be adjusted fully clockwise. The pots are located inside the unit on the bottom board (see Figure 7).

### HIGH RESISTANCE (10k - 3.5M)

1. If the desired resistance is 10k - 3.5M, jumpers JP1 (MAT 1) and JP2 (MAT 2) need to be on one pin (see Figure 5).
2. Use a resistor decade box to set the desired resistance between the ground terminal and ground.
3. Connect the mat wire to the decade box and connect the decade box to ground.
4. Turn the appropriate potentiometer counter-clockwise until the GROUND LED illuminates red and alarm sounds (see Figure 7).
5. Slowly turn the potentiometer clockwise until the GROUND LED illuminates green.
6. Add 10% more resistance (at least 1 ohm) to the decade box and verify that the GROUND LED illuminates red and alarm sounds.
7. Return back to the starting resistance and confirm that the green LED illuminates again. Repeat steps 4-7 if the monitor does not fail with the increased resistance or return to a pass condition.

### LOW RESISTANCE (< 1k)

1. If the desired resistance is < 1k, jumpers JP1 (MAT 1) and JP2 (MAT 2) need to be on both pins (see Figure 5).
2. Use a resistor decade box to set the desired resistance between the ground terminal and ground.
3. Connect the mat wire to the decade box and connect the decade box to ground.
4. Turn the appropriate potentiometer counter-clockwise until the GROUND LED illuminates red and alarm sounds (see Figure 7).
5. Slowly turn the potentiometer clockwise until the GROUND LED illuminates green.
6. Add 10% more resistance (at least 1 ohm) to the decade box and verify that the GROUND LED illuminates red and alarm sounds.
7. Return back to the starting resistance and confirm that the green LED illuminates again. Repeat steps 4-7 if the monitor does not fail with the increased resistance or return to a pass condition.

**Limited Warranty, Warranty Exclusions, Limit of Liability and RMA Request Instructions**

See EMIT's Warranty -

<http://emit.descoindustries.com/Warranty.aspx>

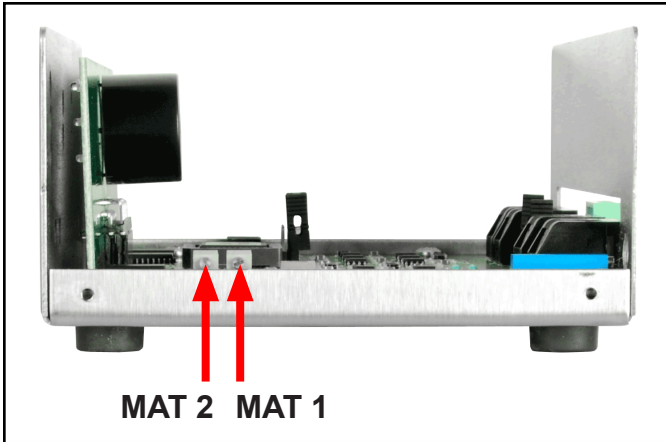

Figure 8. MAT potentiometers

**Specifications**

Operating Voltage	100-240 VAC, 50/60 Hz
Operating Temperature	32°F - 104°F (0 - 40°C)
Monitor Dimensions	5.6" x 4.7" x 2.6" (14.2cm x 11.9cm x 6.6cm)
Monitor Weight	1.6 lbs (0.7 kg)

**TEST VOLTAGES**

Operator	1.25 V
Worksurface	200 mV

**TEST LIMITS**

Operator	Low Fail: < 1.72 megohms Pass: 2 - 9 megohms High Fail: > 11.5 megohms
Worksurface	Pass: < 3.5 megohms Fail: > 3.8 megohms
Charge Detector	Detects > ±1.25 VDC on operator

**NOTE:** Worksurface must have a conductive layer such as Dual Layer Rubber or Dissipative 3-Layer Vinyl or Micastat® Dissipative Laminate with conductive buried layers. EMIT Continuous Monitors are not recommended for use with homogeneous matting.