



Chipsmall Limited consists of a professional team with an average of over 10 year of expertise in the distribution of electronic components. Based in Hongkong, we have already established firm and mutual-benefit business relationships with customers from,Europe,America and south Asia,supplying obsolete and hard-to-find components to meet their specific needs.

With the principle of “Quality Parts,Customers Priority,Honest Operation,and Considerate Service”,our business mainly focus on the distribution of electronic components. Line cards we deal with include Microchip,ALPS,ROHM,Xilinx,Pulse,ON,Everlight and Freescale. Main products comprise IC,Modules,Potentiometer,IC Socket,Relay,Connector.Our parts cover such applications as commercial,industrial, and automotives areas.

We are looking forward to setting up business relationship with you and hope to provide you with the best service and solution. Let us make a better world for our industry!



Contact us

Tel: +86-755-8981 8866 Fax: +86-755-8427 6832

Email & Skype: info@chipsmall.com Web: www.chipsmall.com

Address: A1208, Overseas Decoration Building, #122 Zhenhua RD., Futian, Shenzhen, China



DARTS | SERIES

TEMPERATURE SENSOR PROBES

Introduction

The DARTS series is a line of thin film platinum RTD based temperature sensors ideal for demanding air conditioning, refrigeration and industrial applications where long term reliability is a must. Each configuration is specifically designed to optimize cost, robustness, and high absolute accuracy.



Features

- Available Metric and English Mounting Threads
- Thin Film Platinum temperature sensors displaying high linearity
- Flexibility in insertion depth: 25mm, 35mm, 40mm, 50mm, 70mm
- Straight and bended configurations for rear housing, 0° to 120° to facilitate installation on the engine

Applications

- Industrial Exhaust Gas
- HVAC
- Industrial
- Rugged immersion and air temperature sensing

SPECIFICATIONS

SENSOR FAMILY	DARTS1000-E	DARTS500-B	DARTS500-E	DARTS200-Aw	DARTS200-Ds
SENSOR ELEMENT	PT-1000 platinum RTD	PT-500 platinum RTD	PT-500 platinum RTD	PT-200 platinum RTD	PT-200 platinum RTD
NOMINAL RESISTANCE	1000Ω at 0°C	500Ω at 0°C	500Ω at 0°C	200Ω at 0°C	200Ω at 0°C
TEMPERATURE RANGE	Continuous -40°C to 150°C	Continuous: -40°C to 300°C Peak: 500°C	Continuous: -40°C to 550°C Peak: 600°C	Continuous: -40°C to 750°C Peak: 800°C	Continuous: -40°C to 850°C Peak: 900°C
ACCURACY	±1.0% from -40°C to 150°C	±2.5°C from -40°C to 160°C ±1.5% from 160°C to 300°C	Continuous: -40°C to 550°C Peak: 600°C	±2.5°C from -40°C to 280°C ±0.9% from 280°C to 750°C	±2.5°C from -40°C to 280°C ±0.9% from 280°C to 850°C
RESPONSE TIME T63		<12 seconds at 300°C, air velocity of 11m/s <6.5 seconds at 300°C, air velocity of 70m/s	<12 seconds at 300°C, air velocity of 11m/s <6.5 seconds at 300°C, air velocity of 70m/s	<12 seconds at 300°C, air velocity of 11m/s <6.5 seconds at 300°C, air velocity of 70m/s	<11 seconds at 300°C, air velocity of 11m/s <6.5 seconds at 300°C, air velocity of 70m/s
INSULATION RESISTANCE	>1MΩ at 20°C, VDC 500 Volt				
FASTENING	Mounting Nut				
CONNECTOR	Cable with connector chosen by customer	Integral MLK connector	Cable with connector chosen by customer	Cable with connector chosen by customer	Cable with connector chosen by customer



TYPICAL SENSOR CONSTRUCTION

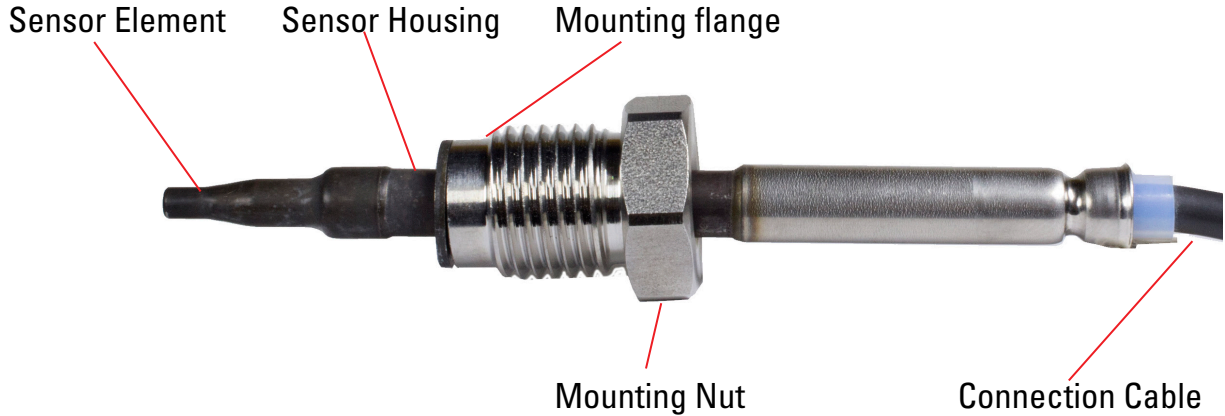

TYPICAL 5V MEASUREMENT CIRCUIT

Pull-Up Voltage	$U_p = +5V \pm 0.1\%$
Pull-Up Resistance	$R_p = 1k\Omega \pm 0.1\%$
A/D Converter Accuracy	10 bit
Polarity	Signal: Grey Ground: White
Operational Current	Between 2.7mA and 4.2mA

(Same methodology applies for other voltage systems (e.g. 3.3V), but operational current must be lower than 5mA)



CONNECTION DIAGRAM

RTD circuit to MCU

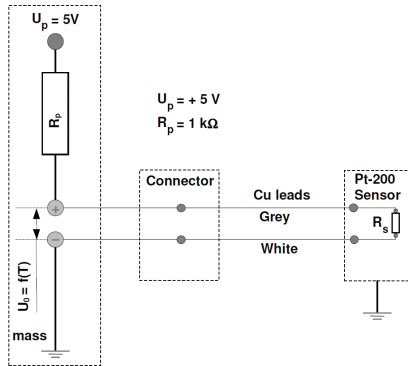

WARNINGS



RISK OF MATERIAL DAMAGE AND HOT ENCLOSURE

- The product's side panels may be hot, allow the product to cool before touching
 - Follow proper mounting instructions including torque values
 - Do not allow liquids or foreign objects to enter this product
- Failure to follow these instructions can result in serious injury, or equipment damage.**

Sensata Technologies, Inc. ("Sensata") data sheets are solely intended to assist designers ("Buyers") who are developing systems that incorporate Sensata products (also referred to herein as "components"). Buyer understands and agrees that Buyer remains responsible for using its independent analysis, evaluation and judgment in designing Buyer's systems and products. Sensata data sheets have been created using standard laboratory conditions and engineering practices. Sensata has not conducted any testing other than that specifically described in the published documentation for a particular data sheet. Sensata may make corrections, enhancements, improvements and other changes to its data sheets or components without notice.

Buyers are authorized to use Sensata data sheets with the Sensata component(s) identified in each particular data sheet. HOWEVER, NO OTHER LICENSE, EXPRESS OR IMPLIED, BY ESTOPPEL OR OTHERWISE TO ANY OTHER SENSATA INTELLECTUAL PROPERTY RIGHT, AND NO LICENSE TO ANY THIRD PARTY TECHNOLOGY OR INTELLECTUAL PROPERTY RIGHT, IS GRANTED HEREIN. SENSATA DATA SHEETS ARE PROVIDED "AS IS". SENSATA MAKES NO WARRANTIES OR REPRESENTATIONS WITH REGARD TO THE DATA SHEETS OR USE OF THE DATA SHEETS, EXPRESS, IMPLIED OR STATUTORY, INCLUDING ACCURACY OR COMPLETENESS. SENSATA DISCLAIMS ANY WARRANTY OF TITLE AND ANY IMPLIED WARRANTIES OF MERCHANTABILITY, FITNESS FOR A PARTICULAR PURPOSE, QUIET ENJOYMENT, QUIET POSSESSION, AND NON-INFRINGEMENT OF ANY THIRD PARTY INTELLECTUAL PROPERTY RIGHTS WITH REGARD TO SENSATA DATA SHEETS OR USE THEREOF.

All products are sold subject to Sensata's terms and conditions of sale supplied at www.sensata.com SENSATA ASSUMES NO LIABILITY FOR APPLICATIONS ASSISTANCE OR THE DESIGN OF BUYERS' PRODUCTS. BUYER ACKNOWLEDGES AND AGREES THAT IT IS SOLELY RESPONSIBLE FOR COMPLIANCE WITH ALL LEGAL, REGULATORY AND SAFETY-RELATED REQUIREMENTS CONCERNING ITS PRODUCTS, AND ANY USE OF SENSATA COMPONENTS IN ITS APPLICATIONS, NOTWITHSTANDING ANY APPLICATIONS-RELATED INFORMATION OR SUPPORT THAT MAY BE PROVIDED BY SENSATA.

Mailing Address: Sensata Technologies, Inc., 529 Pleasant Street, Attleboro, MA 02703, USA.

CONTACT US

Americas

+1 (888) 438 2214
sensors@sensata.com

Europe, Middle East & Africa

+359 (2) 804 7165
temperature-info.eu@sensata.com

Asia Pacific

sales.isasia@list.sensata.com
 China +86 (21) 2306 1500
 Japan +81 (45) 277 7117
 Korea +82-10-9218-1179
 India +91 (80) 67920890
 Rest of Asia +886 (2) 27602006
 ext 2808