



Chipsmall Limited consists of a professional team with an average of over 10 year of expertise in the distribution of electronic components. Based in Hongkong, we have already established firm and mutual-benefit business relationships with customers from,Europe,America and south Asia,supplying obsolete and hard-to-find components to meet their specific needs.

With the principle of “Quality Parts,Customers Priority,Honest Operation,and Considerate Service”,our business mainly focus on the distribution of electronic components. Line cards we deal with include Microchip,ALPS,ROHM,Xilinx,Pulse,ON,Everlight and Freescale. Main products comprise IC,Modules,Potentiometer,IC Socket,Relay,Connector.Our parts cover such applications as commercial,industrial, and automotives areas.

We are looking forward to setting up business relationship with you and hope to provide you with the best service and solution. Let us make a better world for our industry!



## Contact us

Tel: +86-755-8981 8866 Fax: +86-755-8427 6832

Email & Skype: info@chipsmall.com Web: www.chipsmall.com

Address: A1208, Overseas Decoration Building, #122 Zhenhua RD., Futian, Shenzhen, China



THIS DRAWING IS UNPUBLISHED. RELEASED FOR PUBLICATION  
 © COPYRIGHT - By - ALL RIGHTS RESERVED.

REVISIONS				
P	LTR	DESCRIPTION	DATE	APVD
	F3	REVISED PER ECO-15-016493	26NOV2015	NK DR

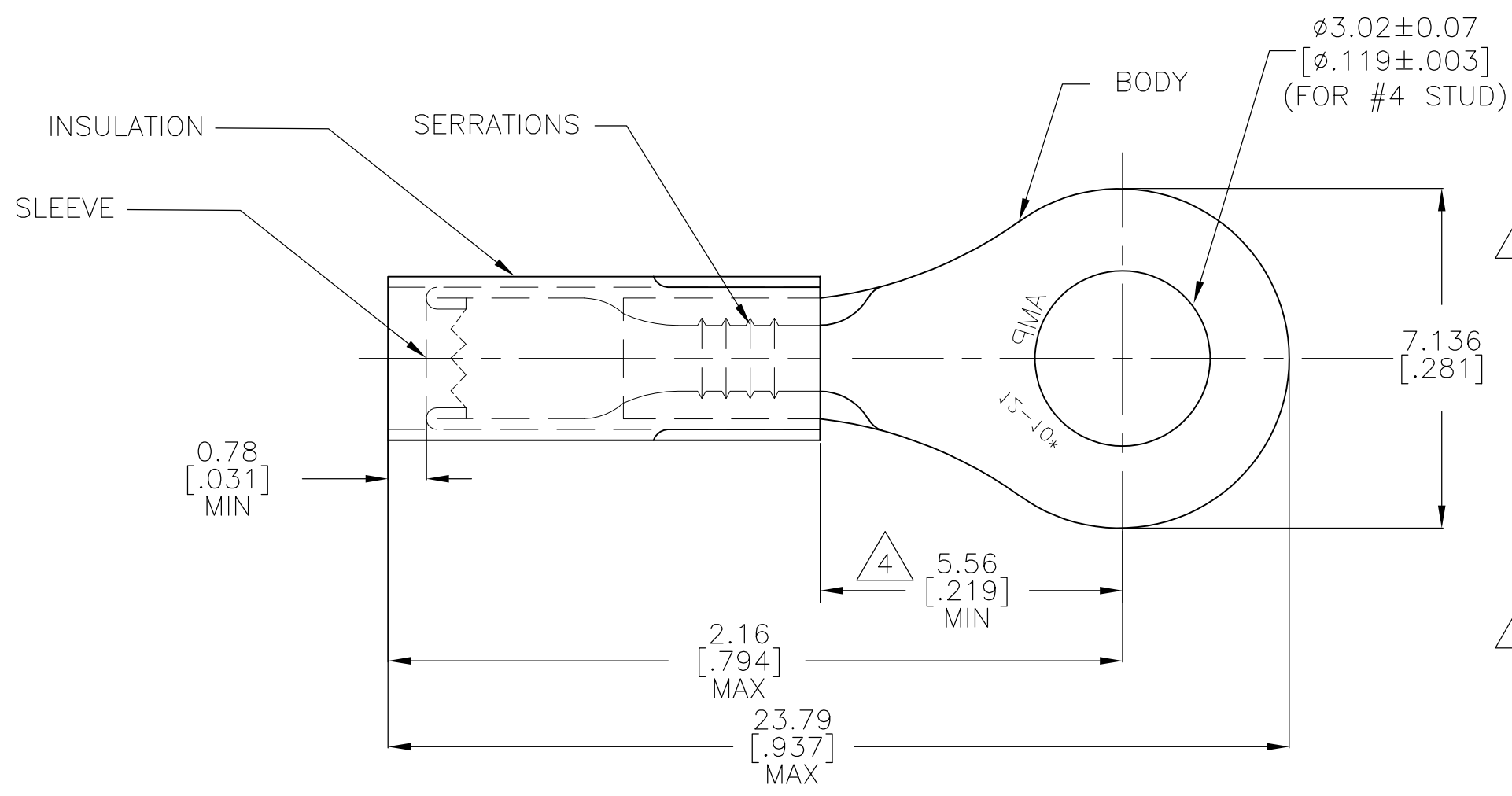

- 1 BODY: COPPER ASTM B152  
NICKEL PL SAE AMS QQ-N-290  
0.0076 [.0003] AVG. EXT. THK  
SLEEVE: COPPER ASTM B152  
NICKEL PL SAE AMS QQ-N-290  
0.00076 [.00003] AVG. EXT. THK
- 2 FOR 2.59 [.102] TO 5.43 [.214]  
WIRE INSULATION DIA.
- 3 TONGUE MATERIAL THK: 0.99±0.05 [.039±.002]
- 4 DIMENSION APPLIES FROM EDGE OF  
METAL WIRE BARREL TO CENTER OF  
STUD HOLE

PRELIMINARY	1000	LOOSE PIECE	50844-2	PVDF COLOR:BLACK
	1000	LOOSE PIECE	50844	PTFE (ASTM D3295) COLOR: BLACK
	QTY	PACKAGE TYPE	PART NO.	INSULATION MATERIAL

AMP INCORPORATED CUSTOMER SERVICE SYSTEMS		MAX RECOMMENDED OPERATING TEMPERATURE: 288°C [550°F]	THIS DRAWING IS A CONTROLLED DOCUMENT.		DWN 13OCT2015 NAGALAKSHMI K	TE Connectivity				
FOR ADDITIONAL PRODUCT INFORMATION OR COPIES OF DRAWINGS AND TECHNICAL DOCUMENTS	PRODUCT INFORMATION CENTER 1-800-522-6752	VOLTAGE RATING: 300V MAX	DIMENSIONS: mm [INCHES]	TOLERANCES UNLESS OTHERWISE SPECIFIED:	CHK 13OCT2015 MERCURIO MAURIZIO					NAME WIRE TERMINAL PIDG, STRATO-THERM, RING TONGUE WIRE SIZE:12-10
FOR APPLICATION TOOLING INFORMATION	TOOLING ASSISTANCE CENTER 1-800-722-1111	CIRCULAR MIL AREA: 2.62-6.64mm²[5,180-13,100] STRANDED WIRE ONLY		0 PLC ± - 1 PLC ± - 2 PLC ± 0.20 [.008] 3 PLC ± - 4 PLC ± - ANGLES ± 5°	APVD 13OCT2015 MERCURIO MAURIZIO	PRODUCT SPEC	SIZE	CAGE CODE	DRAWING NO	RESTRICTED TO
FOR ORDER ENTRY	1-800-526-5142		MATERIAL	FINISH	WEIGHT -		A3	00779	C-50844	
CUSTOMER DRAWING						SCALE	NTS	SHEET	1 OF 1	REV F3