



Chipsmall Limited consists of a professional team with an average of over 10 year of expertise in the distribution of electronic components. Based in Hongkong, we have already established firm and mutual-benefit business relationships with customers from,Europe,America and south Asia,supplying obsolete and hard-to-find components to meet their specific needs.

With the principle of "Quality Parts,Customers Priority,Honest Operation,and Considerate Service",our business mainly focus on the distribution of electronic components. Line cards we deal with include Microchip,ALPS,ROHM,Xilinx,Pulse,ON,Everlight and Freescale. Main products comprise IC,Modules,Potentiometer,IC Socket,Relay,Connector.Our parts cover such applications as commercial,industrial, and automotives areas.

We are looking forward to setting up business relationship with you and hope to provide you with the best service and solution. Let us make a better world for our industry!



## Contact us

Tel: +86-755-8981 8866 Fax: +86-755-8427 6832

Email & Skype: info@chipsmall.com Web: www.chipsmall.com

Address: A1208, Overseas Decoration Building, #122 Zhenhua RD., Futian, Shenzhen, China



NOTES:

1. COIL WOUND USING COPPER MAGNET WIRE WITH CLASS 155 SINGLE BUILD POLYURETHANE INSULATION.
2. FINISH WIRE ON COIL IS SECURED WITH BLUE DOT OF PAINT.
3. BOBBIN IS FULLY ANNEALED HYMU80 WITH PARYLENE COATING.
4. WITH A POSITIVE DC VOLTAGE APPLIED TO THE "FINISH" WIRE, THE MAGNETIC FIELD WILL ATTRACT A COMPASS NEEDLE AS SHOWN.
5. START AND FINISH WIRE TO LIE TIGHT AGAINST COIL.
6. COIL TO BE DIPPED AT LEAST 2 TIMES WITH 13-863 (CONATHANE CE-1164) TO PROVIDE A UNIFORM LAYER OF PROTECTION ON COIL WIRES.
7. SENSITIVITY MEASUREMENT IN dB re 1.0 VOLT WITH A MAGNETIC FIELD STRENGTH OF 1 A/M APPLIED TO THE COIL, LONG AXIS OF THE TELECOIL IS PARALLEL TO THE TEST MAGNETIC FIELD.
8. SOLDER SHALL NOT CONTAIN LEAD. MUST BE ROHS COMPLIANT.

ELECTRICAL CHARACTERISTICS

# OF TURNS	WIRE SIZE	INDUCTANCE @ 1KHZ (mH)±15%	DCR@25°C (ohms)±10%	SENSITIVE @ 1KHZ (dB) ±2dB	w/10k Ω LOAD
2500	51H HIGH RESISTANCE	41	385	-65.5	-66.0

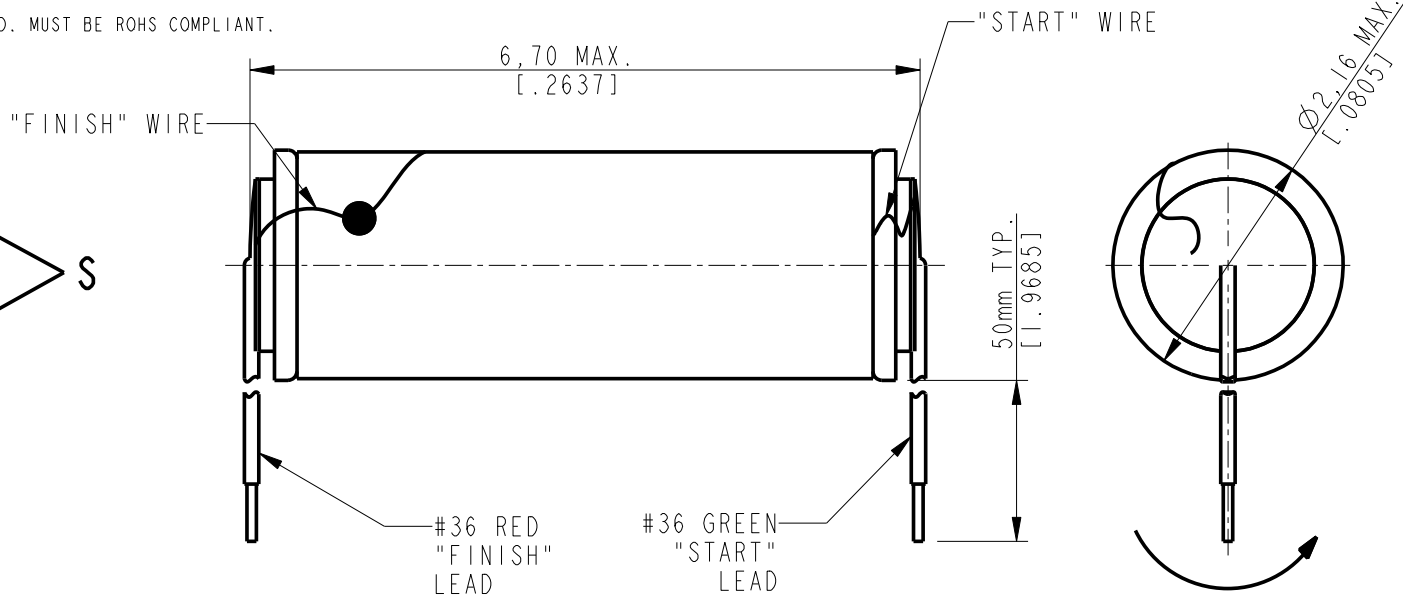
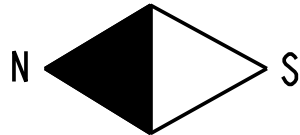

**RED CONTROLLED**

				SCALE: 15:1		MATERIAL:
				FUNDAMENTAL TOLERANCE: ± 0.03 [0.001]		HEAT TREATMENT:
				ANGLE TOLERANCE: ± 1°		FINISH:
				MISMATCH TOLERANCE: ± 0.03 [0.001]		TITLE:
C	C10110669	1-7-10	SDZ	DATE	NAME	<b>FINISHED 01 STYLE BOBBIN W/2 TERMINAL PADS</b>
B	C10104995	11/02/06	BCS	DESIGNED 01/10/06	BCS	
A	C10103768	01/12/06	BCS	CHECKED 01/10/06	BCS	
REV.	CHANGE #	DATE	NAME	RELEASED 01/10/06	TDS	
PROPRIETARY NOTE: THIS DOCUMENT CONTAINS INFORMATION WHICH IS THE PROPRIETARY PROPERTY OF KNOWLES ELECTRONICS, LLC. OR ITS AFFILIATED ENTITIES. IT IS ISSUED IN STRICT CONFIDENCE AND SHALL NOT BE REPRODUCED, COPIED, USED, OR DISCLOSED TO ANY THIRD PARTY PARTIALLY OR WHOLLY IN ANY MANNER WITHOUT PRIOR WRITTEN PERMISSION OF, AND MUST BE RETURNED UPON REQUEST BY, KNOWLES ELECTRONICS, LLC.						RELEASED LEVEL: Active
						DRAWING NUMBER: 5100-253584
						SHEETS: 1 of 1