



Chipsmall Limited consists of a professional team with an average of over 10 year of expertise in the distribution of electronic components. Based in Hongkong, we have already established firm and mutual-benefit business relationships with customers from,Europe,America and south Asia,supplying obsolete and hard-to-find components to meet their specific needs.

With the principle of “Quality Parts,Customers Priority,Honest Operation,and Considerate Service”,our business mainly focus on the distribution of electronic components. Line cards we deal with include Microchip,ALPS,ROHM,Xilinx,Pulse,ON,Everlight and Freescale. Main products comprise IC,Modules,Potentiometer,IC Socket,Relay,Connector.Our parts cover such applications as commercial,industrial, and automotives areas.

We are looking forward to setting up business relationship with you and hope to provide you with the best service and solution. Let us make a better world for our industry!



Contact us

Tel: +86-755-8981 8866 Fax: +86-755-8427 6832

Email & Skype: info@chipsmall.com Web: www.chipsmall.com

Address: A1208, Overseas Decoration Building, #122 Zhenhua RD., Futian, Shenzhen, China



THIS DRAWING IS UNPUBLISHED. RELEASED FOR PUBLICATION
 © COPYRIGHT BY TYCO ELECTRONICS CORPORATION. ALL RIGHTS RESERVED.

P	LTR	DESCRIPTION	DATE	DWN	APVD
B		EH10-0680-05	02-JUN-05	BSV	BM
B1		REVISED PER ECO-09-024927	07-NOV-09	KK	AEG
C		ECR-10-018652	10SEP10	SW	MQW

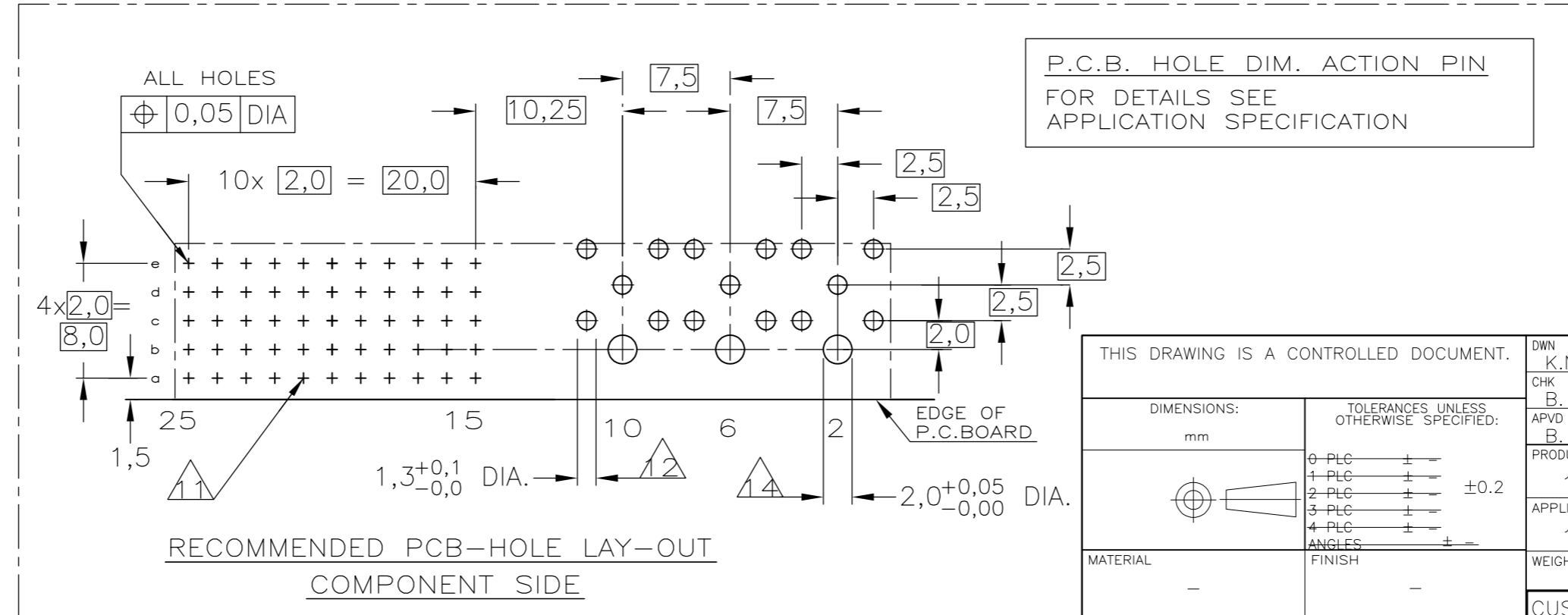
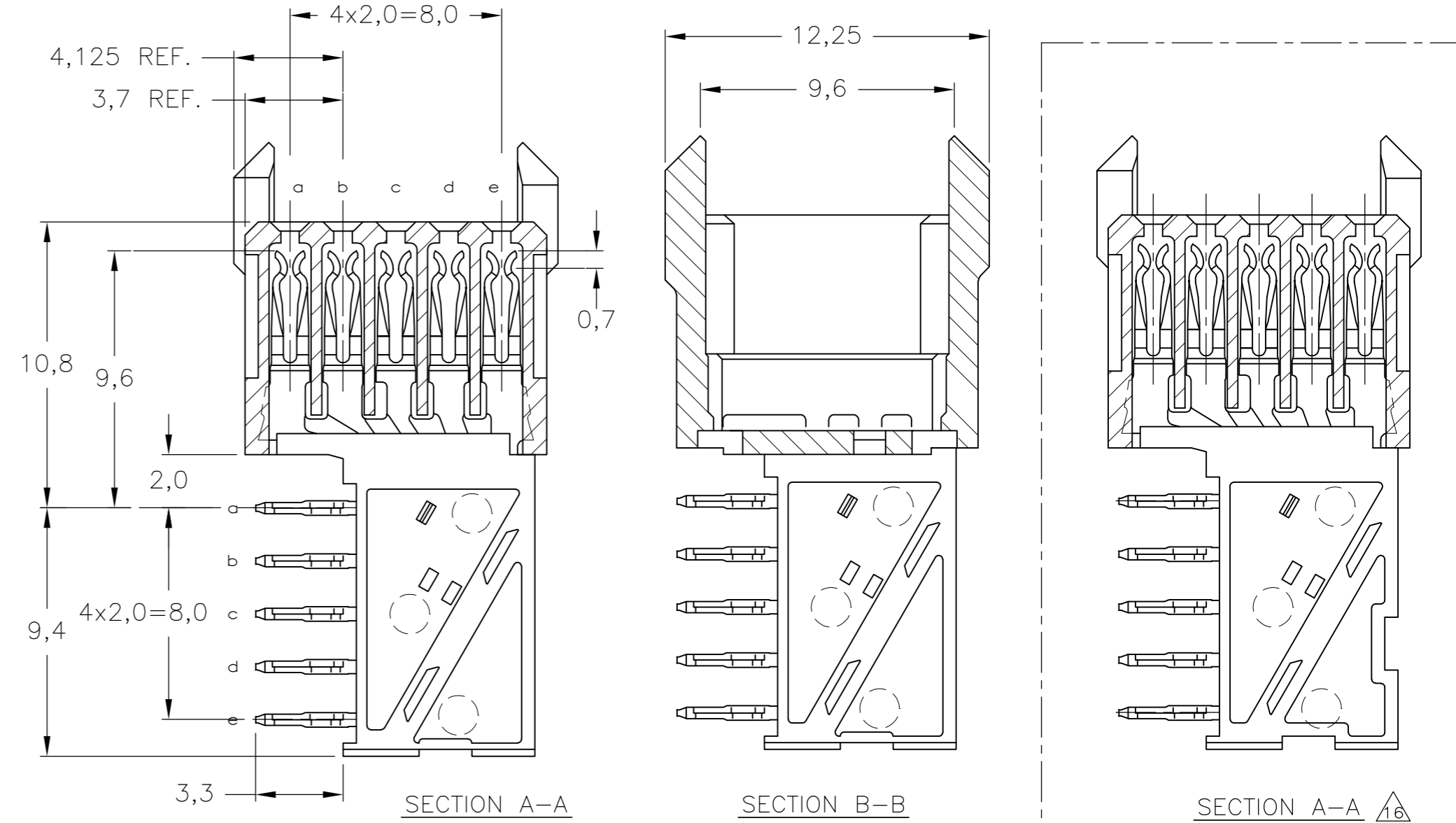
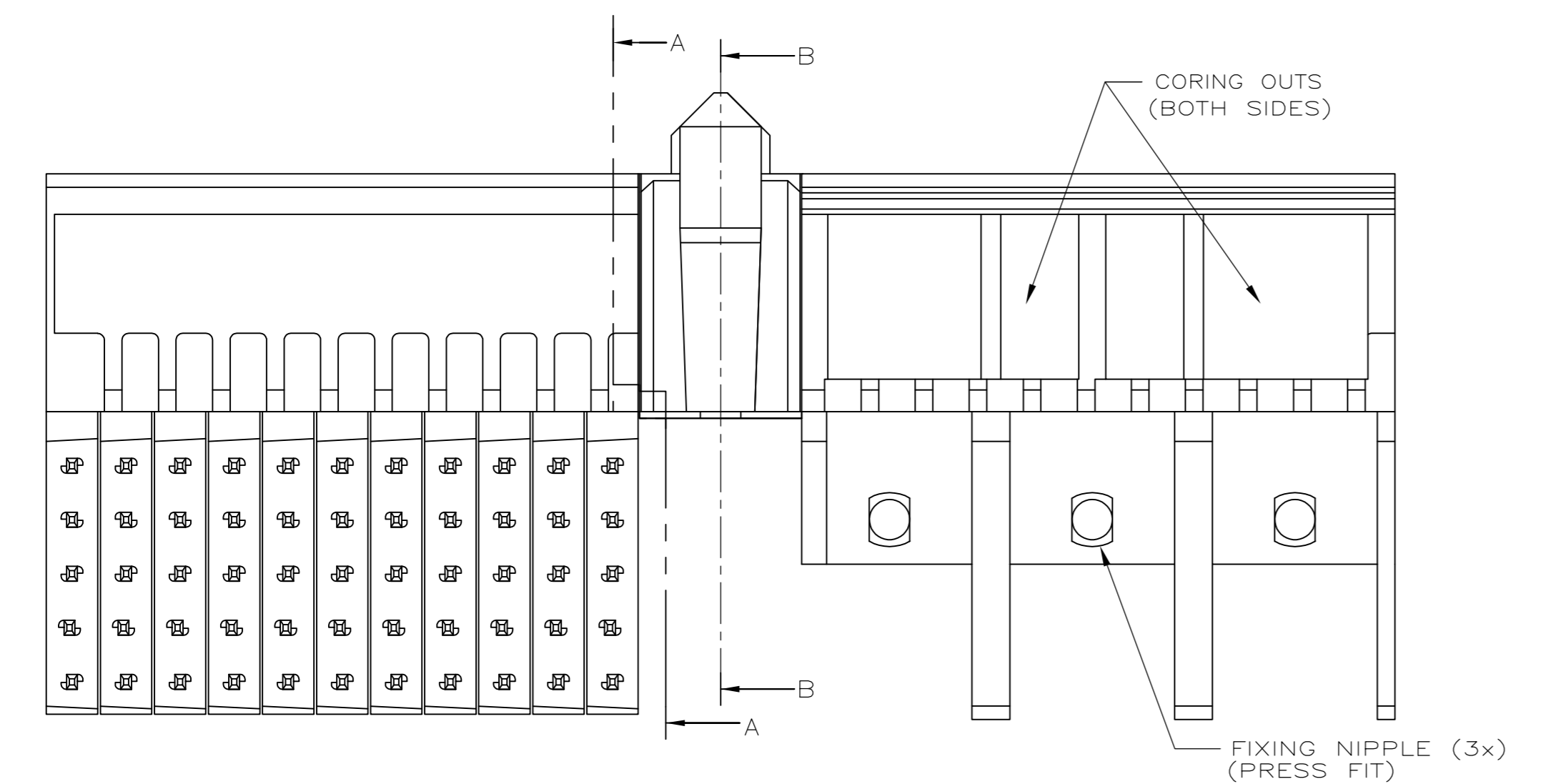
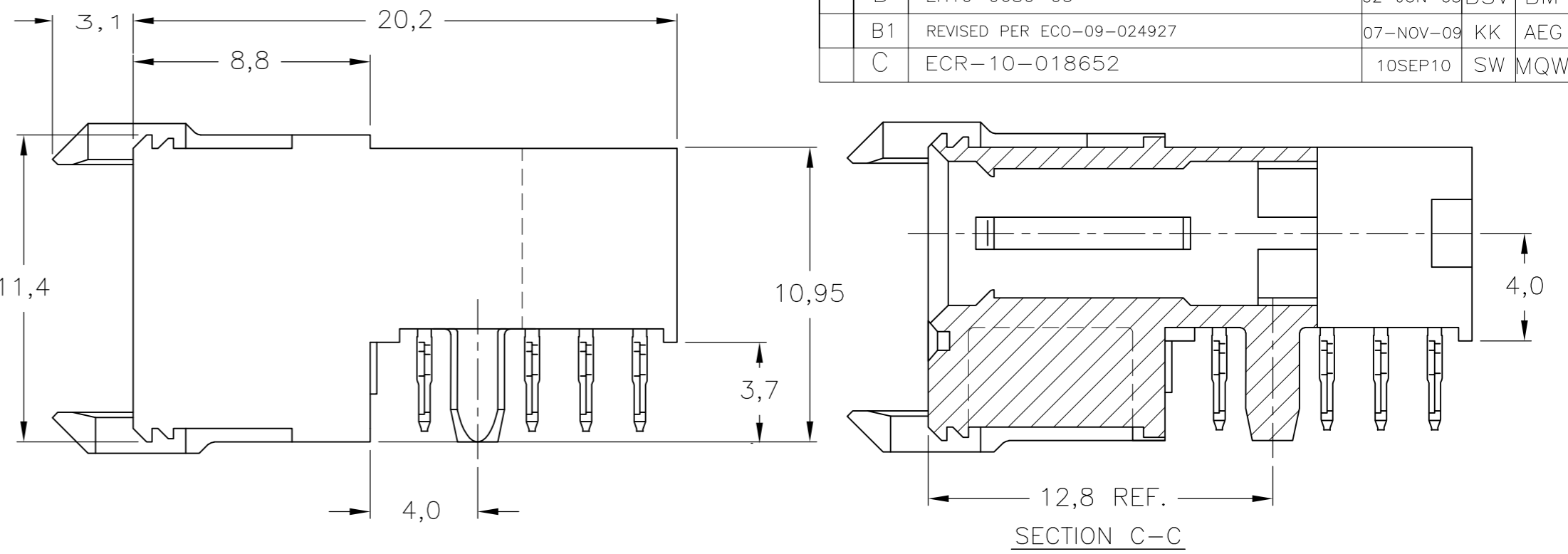
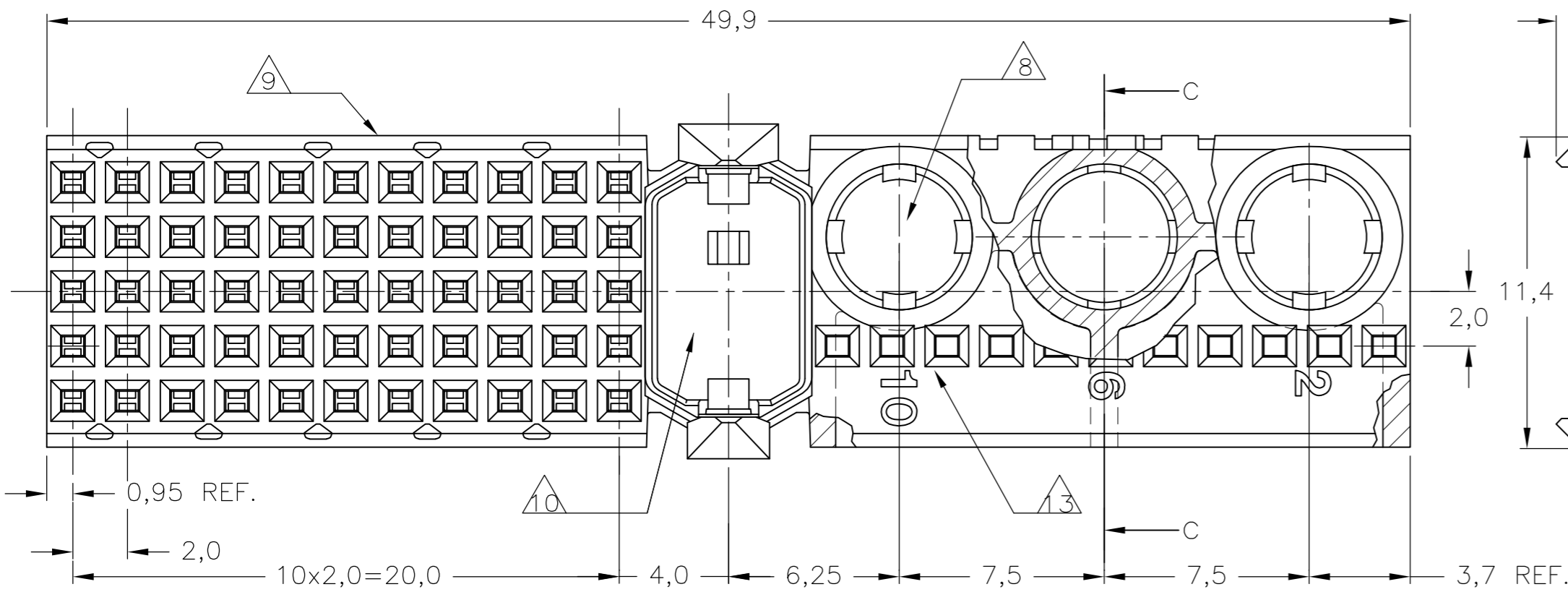

FINISH	MATERIALS	PARTNUMBER
2 6 7	1	1-5100750-9
2 5 7	1	5100750-9
2 4	1	5100750-4
2 3	1	5100750-1

THIS DRAWING IS A CONTROLLED DOCUMENT.

DWN	K.N.KIRAN	10AUG2004
CHK	B. MOOIJ	23SEP2004
APVD	B. MOOIJ	23SEP2004
PRODUCT SPEC	108-19082	
APPLICATION SPEC	114-19029	
WEIGHT	-	

TOLERANCES UNLESS OTHERWISE SPECIFIED:
 0 PLG ±
 1 PLG ±
 2 PLG ±
 3 PLG ±
 4 PLG ±
 ANGLES ±
 FINISH

NAME: Tyco Electronics Corporation
 's-Hertogenbosch, 5222AR-32

Z-PACK 2mm HM
 TYPE M FEMALE CONNECTOR

SIZE	CAGE CODE	DRAWING NO	RESTRICTED TO
A2	00779	C=5100750	-

CUSTOMER DRAWING SCALE 5:1 SHEET 1 OF 2 REV C

THIS DRAWING IS UNPUBLISHED. RELEASED FOR PUBLICATION
 © COPYRIGHT BY TYCO ELECTRONICS CORPORATION. ALL RIGHTS RESERVED.

LOC	DIST	REVISIONS					
		P	LTR	DESCRIPTION	DATE	DWN	APVD
H	-	-	-	SEE SHEET 1	-	-	-

NOTES:

- 1 MATERIAL HOUSING : GREY GLASSFILLED POLYESTER.
MATERIAL CONTACTS: PHOSPHORBRONZE.
- 2 GENERAL PLATING SPECIFICATION: UNDERPLATING
(ENTIRE CONTACT): 1,27µm NICKEL MIN. AND ACTION
PIN: 0,5µm TIN MIN.
FOR PLATING OF MATING SURFACES SEE APPLICABLE
SPECIFICATION REFERENCE FOR EACH DASH NUMBER.
- 3 CONFORMS TO ALL TESTING ACCORDING IEC 61076-4-101
PERFORMANCE LEVEL 2.
- 4 CONFORMS TO ALL TESTING ACCORDING IEC 61076-4-101
PERFORMANCE LEVEL 1.
- 5 CONNECTOR TESTED AND QUALIFIED AGAINST TELCORDIA GR-1217-CORE QUALITY LEVEL III,
CENTRAL OFFICE APPLICATIONS.
- 6 CONNECTOR TESTED AND QUALIFIED AGAINST TELCORDIA GR-1217-CORE QUALITY LEVEL III,
UNCONTROLLED ENVIRONMENT APPLICATIONS.
- 7 CONNECTOR LUBRICATED WITH TELCORDIA GR-1217-CORE APPROVED LUBRICANT.
- 8 CONTACT CAVITIES (3x) SUITABLE FOR 4,8 DIA. HIGH CURRENT,
HIGH FREQUENCY OR FIBRE OPTIC CONTACTS AS PER DIN 41626
(SEE ALSO NOTE 12).
- 9 CONNECTOR PRINTED WITH PARTNUMBER AND DATECODE.
THE MARKING CAN APPEAR ON THE FRONT SIDE OR ON THE BACK SIDE.
- 10 AREA RESERVED FOR KEYING PART, BASIC P/N 100526.
- 11 PLATED-THROUGH HOLES AT 2x2mm SQUARE GRID (55 HOLES).
- 12 1,3 DIA. PLATED-THROUGH HOLES (15x) CAN BE OMITTED
IF SPECIAL CONTACTS WITH CABLE CONNECTION OR FIBRE
OPTIC CONTACTS ARE USED.
- 13 THIS ROW OF 11 CAVITIES (B1 TO B11) FOR
CONNECTOR ASSEMBLY PURPOSE ONLY.
- 14 NOT PLATED-THROUGH HOLES (3x).
- 15 FITS WITH INTEGRATED GROUND RETURN UPPERSHIELD,
BASIC P.N. 5352111 AND INTEGRATED GROUND
RETURN LOWERSHIELD, BASIC P.N. 5352112
- 16 CONNECTOR ASSEMBLED WITH REDESIGNED CONTACTS.
CONTACTS HAVE A CORING-OUT IN THE PLASTIC.
- 17 OBSOLETE PARTS: OBSOLETE CIS STREAMLINING PER D.RENAUD/D.SINISI

THIS DRAWING IS A CONTROLLED DOCUMENT.		DWN K.N.KIRAN 10AUG2004	Tyco Electronics Corporation 's-Hertogenbosch,5222AR-32	
DIMENSIONS: mm		CHK B. MOOIJ 23SEP2004	NAME Z-PACK 2mm HM TYPE M FEMALE CONNECTOR	
TOLERANCES UNLESS OTHERWISE SPECIFIED: 0-PLC ± 1-PLC ± 2-PLC ± ±0.2 3-PLC ± 4-PLC ± ANGLES ±		APVD B. MOOIJ 23SEP2004	RESTRICTED TO -	
MATERIAL -		PRODUCT SPEC 108-19082	SIZE A2	CAGE CODE 00779
FINISH -		APPLICATION SPEC 114-19029	DRAWING NO C=5100750	
		WEIGHT -	SCALE 5:1	
		CUSTOMER DRAWING		SHEET 2 OF 2
				REV C

5100750