



Chipsmall Limited consists of a professional team with an average of over 10 year of expertise in the distribution of electronic components. Based in Hongkong, we have already established firm and mutual-benefit business relationships with customers from,Europe,America and south Asia,supplying obsolete and hard-to-find components to meet their specific needs.

With the principle of “Quality Parts,Customers Priority,Honest Operation,and Considerate Service”,our business mainly focus on the distribution of electronic components. Line cards we deal with include Microchip,ALPS,ROHM,Xilinx,Pulse,ON,Everlight and Freescale. Main products comprise IC,Modules,Potentiometer,IC Socket,Relay,Connector.Our parts cover such applications as commercial,industrial, and automotives areas.

We are looking forward to setting up business relationship with you and hope to provide you with the best service and solution. Let us make a better world for our industry!



Contact us

Tel: +86-755-8981 8866 Fax: +86-755-8427 6832

Email & Skype: info@chipsmall.com Web: www.chipsmall.com

Address: A1208, Overseas Decoration Building, #122 Zhenhua RD., Futian, Shenzhen, China



LOC	DIST	REV	DATE	BY	CHKD	APPD
AD	00	B1				
			18MAR2011	RK	HMR	

REVISIONS

REV	DESCRIPTION	DATE	BY	APPD
B1	REVISED PER ECO-11-005027	18MAR2011	RK	HMR

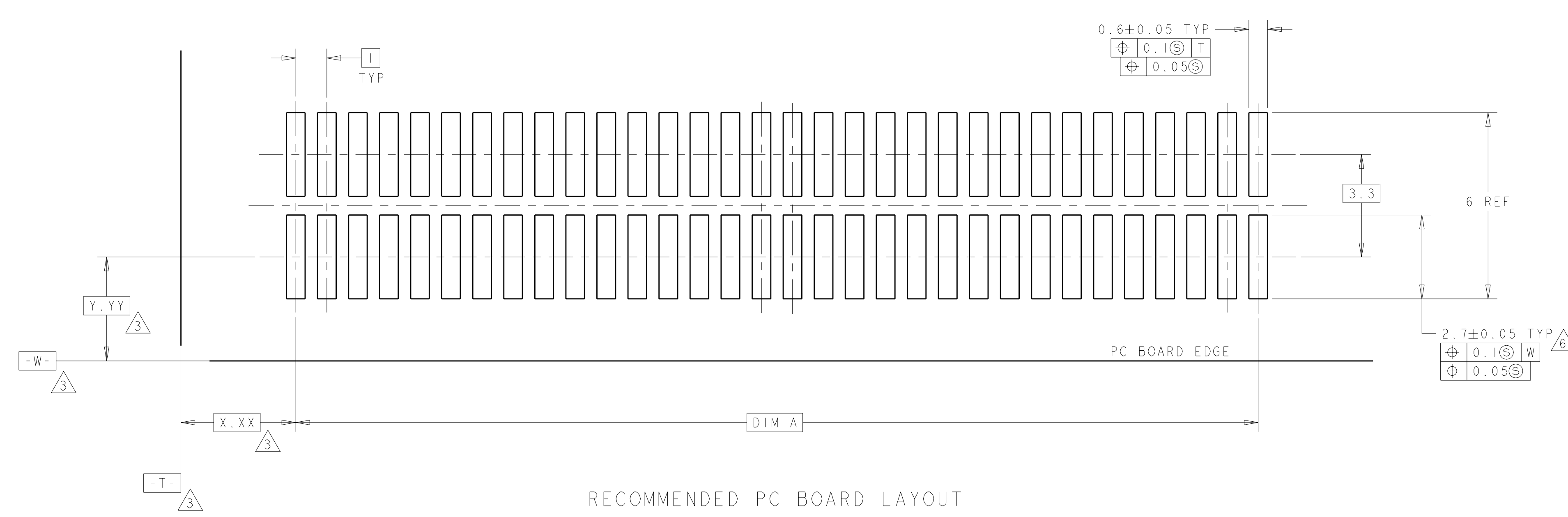
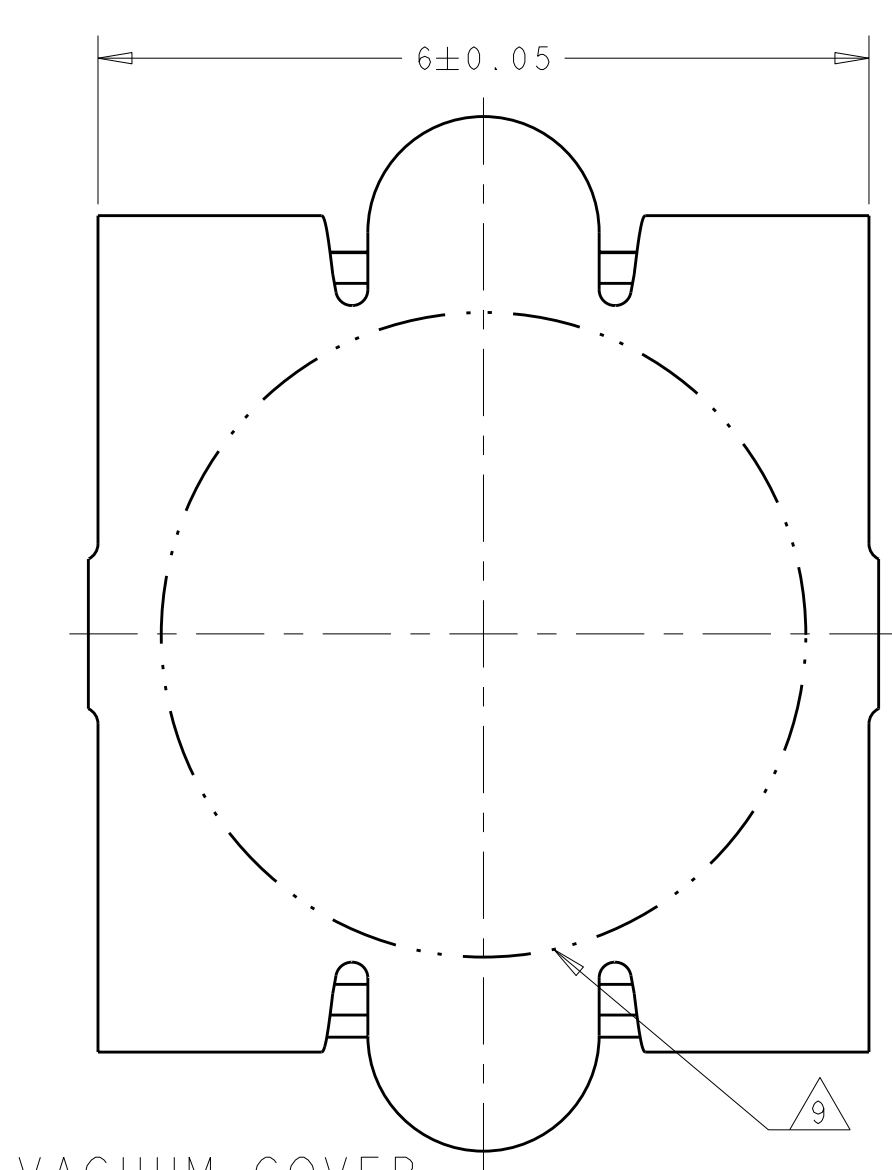
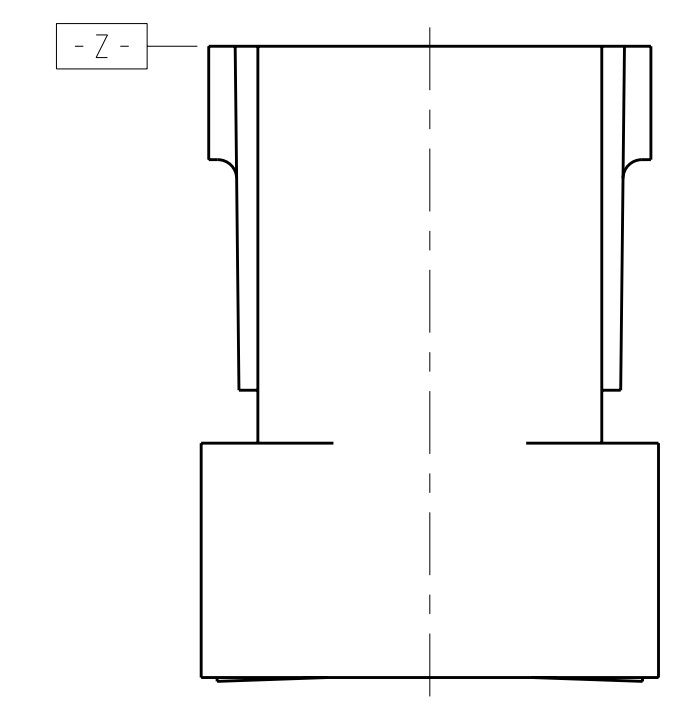
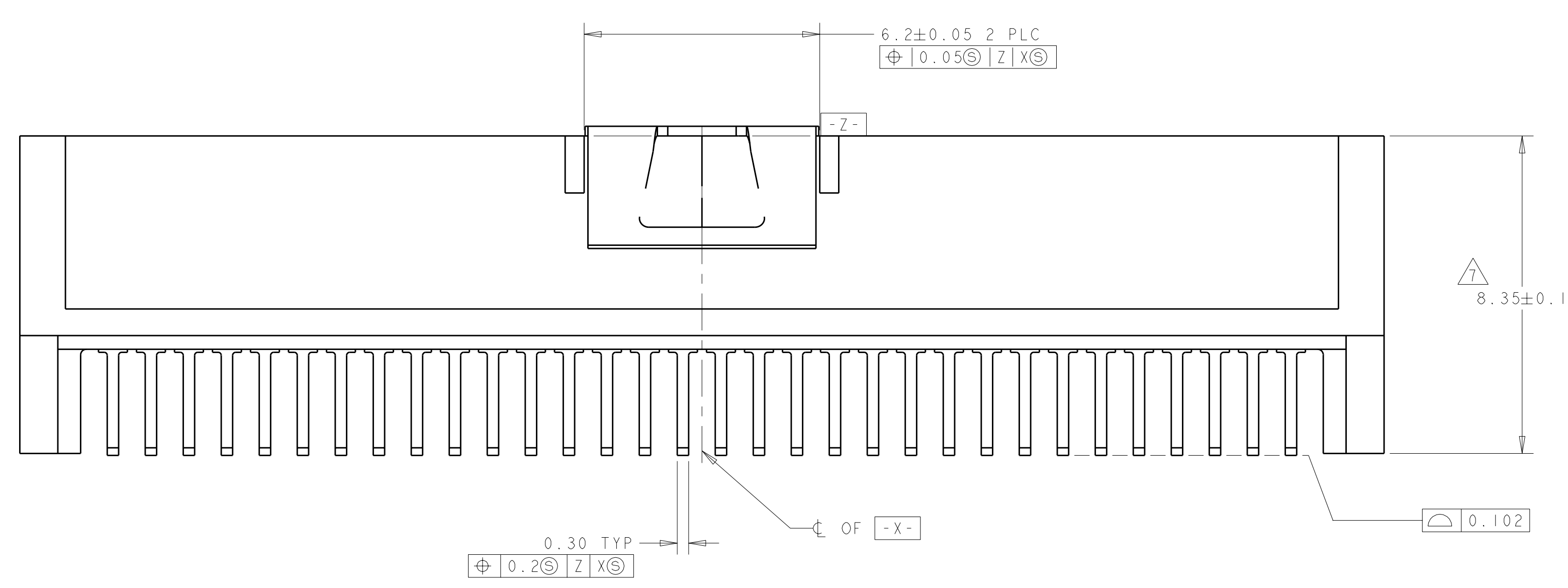
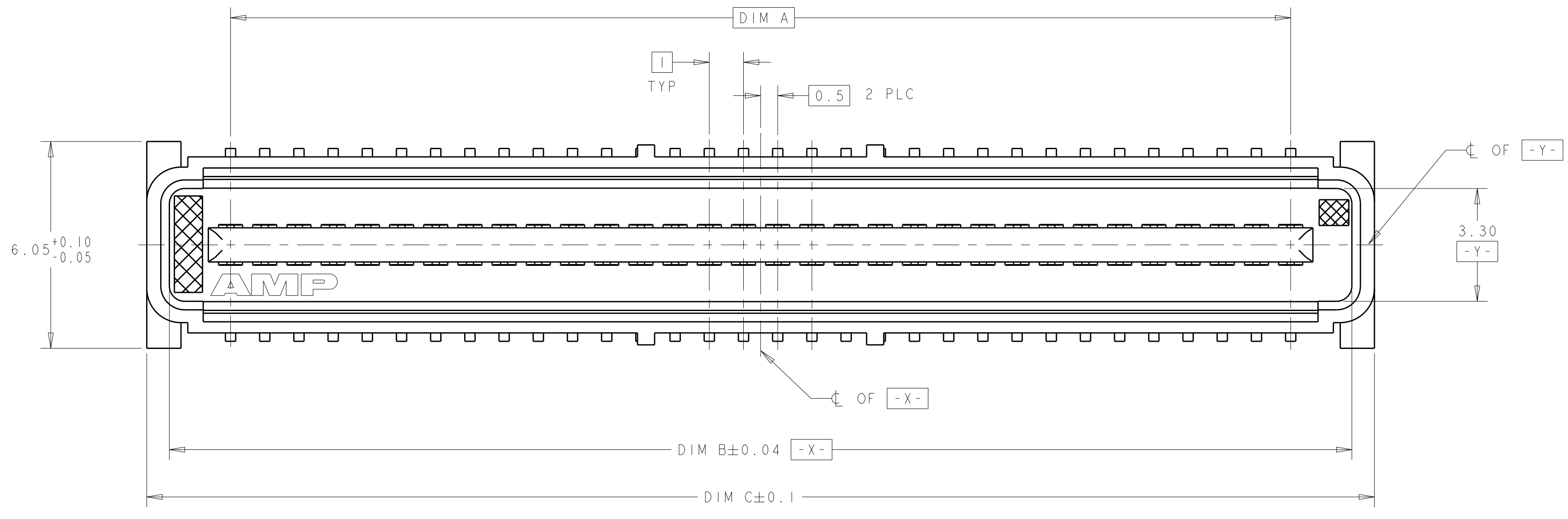

- 1. HOUSING MATERIAL: LIQUID CRYSTAL POLYMER COLOR: BLACK. CONTACT MATERIAL: PHOSPHOR BRONZE.
- 2. CONTACT FINISH: NICKEL UNDERPLATE ALL OVER, MATING SURFACES PLATED TO MEET PLI PERFORMANCE REQUIREMENTS OF INDUSTRY SPECIFICATION EIA-700AAAB, SOLDER TAILS PLATED TIN.
- 3. DATUM LOCATIONS AND BASIC DIMENSIONS TO BE ESTABLISHED BY THE CUSTOMER. CONSULT AMP ENGINEERING WHEN PLACING MULTIPLE CONNECTORS ON A PC BOARD.
- 4. PACKAGED IN TAPE ON REEL PER EIA-481.
- 5. VACUUM COVER DESIGNED FOR 4mm DIA. NOZZLE. VACUUM COVER TO BE REMOVED AFTER SOLDERING. VACUUM COVER REMOVED FROM SOME VIEWS FOR DIMENSIONAL CLARITY.
- 6. SHORTER SOLDER LANDS MAY BE USED PER EIA 700AAAB. HOWEVER 2.7 LENGTH ASSURES OPTIMUM SOLDER FILLET REGARDLESS OF MANUFACTURER OF CONNECTOR.
- 7. REFERRED TO AS DIM N IN EIA 700AAAB SPECIFICATION.
- 8. CORRUGATED REEL, HOLDS 400 CONNECTORS PER REEL 330.2[13.00] DIA REEL; 88.9[3.50] REEL CORE. PLASTIC REEL, HOLDS 250 CONNECTORS PER REEL 330.2[13.00] DIA REEL; 177.8[7.00] REEL CORE.
- 9. 5.5 MIN DIAMETER TARGET AREA FOR VACUUM PICK-UP.
- 10. CONTACT FINISH: 0.00381 MINIMUM MATTE TIN PER ASTM B 545 ON SOLDER AREA, 0.00127 MINIMUM GOLD PER ASTM B 488 ON MATING AREA, BOTH OVER 0.00127 MINIMUM NICKEL PER SAE-AMS-QQ-N-290 ON ENTIRE CONTACT.

FINISH	REEL QTY	DIM C	DIM B	DIM A	MATING CONNECTOR	STACK HEIGHTS	POS	PART NUMBER
								1-5120534-2
								1-5120534-2
								1-5120534-2
								1-5120534-1
								1-5120534-1
								1-5120534-1
								1-5120534-1
								1-5120534-1
								1-5120534-1
								1-5120534-3
								1-5120534-3
								1-5120534-3
								1-5120534-2
								1-5120534-2
								1-5120534-2
								1-5120534-1
								1-5120534-1
								1-5120534-1

THIS DRAWING IS A CONTROLLED DOCUMENT.

AMP TE Connectivity

DIMENSIONS: mm	TOLERANCES UNLESS OTHERWISE SPECIFIED:	DRAWN: B. CARBO	30SEP04
\pm 0.10	0.10	CHKD: R. WERTZ	30SEP04
\pm 0.03	0.03	APPD: R. WERTZ	30SEP04
\pm 0.003	0.003		
\pm 0.001	0.001		
ANGLES			
FINISH			

MATERIAL	SEE TABLE	WEIGHT		CUSTOMER DRAWING	SCALE	17:1	SHEET	1	OF	1	REV	B1
----------	-----------	--------	--	------------------	-------	------	-------	---	----	---	-----	----

PRODUCT SPEC
APPLICATION SPEC
SIZE CAGE CODE DRAWING NO. RESTRICTED TO
A100779C-5120534