



Chipsmall Limited consists of a professional team with an average of over 10 year of expertise in the distribution of electronic components. Based in Hongkong, we have already established firm and mutual-benefit business relationships with customers from,Europe,America and south Asia,supplying obsolete and hard-to-find components to meet their specific needs.

With the principle of “Quality Parts,Customers Priority,Honest Operation,and Considerate Service”,our business mainly focus on the distribution of electronic components. Line cards we deal with include Microchip,ALPS,ROHM,Xilinx,Pulse,ON,Everlight and Freescale. Main products comprise IC,Modules,Potentiometer,IC Socket,Relay,Connector.Our parts cover such applications as commercial,industrial, and automotives areas.

We are looking forward to setting up business relationship with you and hope to provide you with the best service and solution. Let us make a better world for our industry!



Contact us

Tel: +86-755-8981 8866 Fax: +86-755-8427 6832

Email & Skype: info@chipsmall.com Web: www.chipsmall.com

Address: A1208, Overseas Decoration Building, #122 Zhenhua RD., Futian, Shenzhen, China



LOC		DIST		REVISIONS			
F	L/R	DESCRIPTION	DATE	DRN	APVD		
0		RELEASED PER EC 0512-0287-04	22 JUN 05	AWF	AWF		

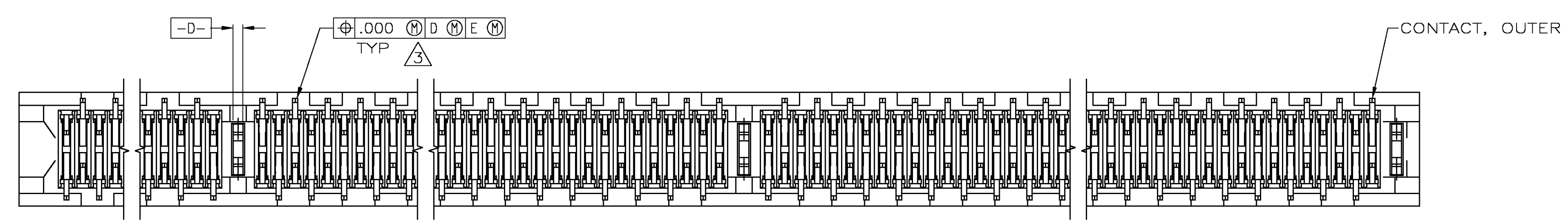
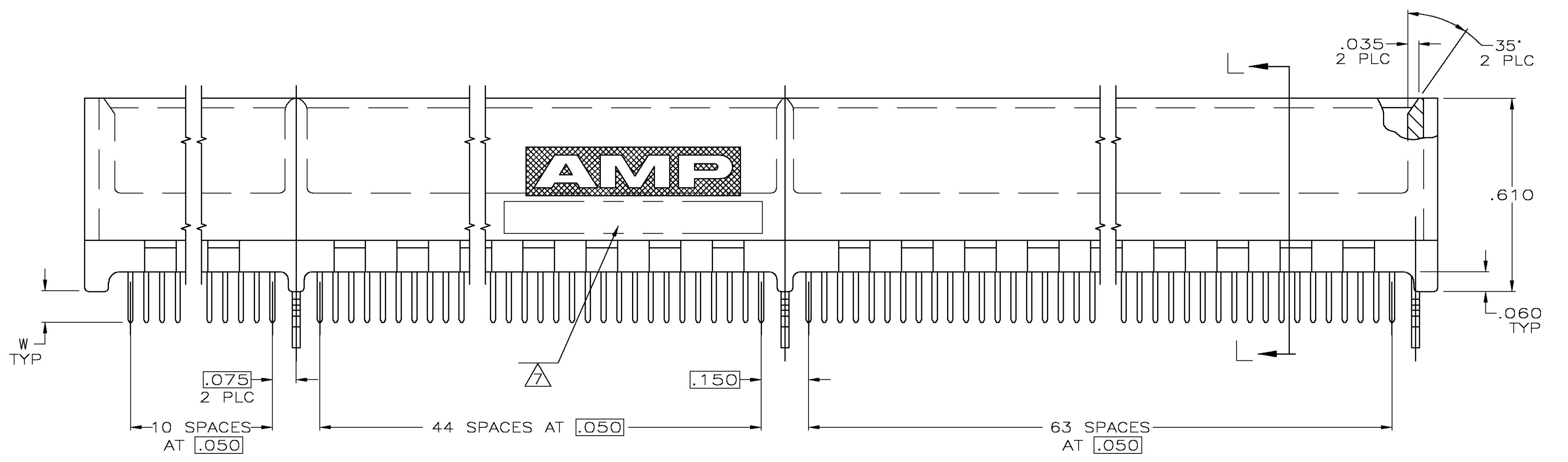
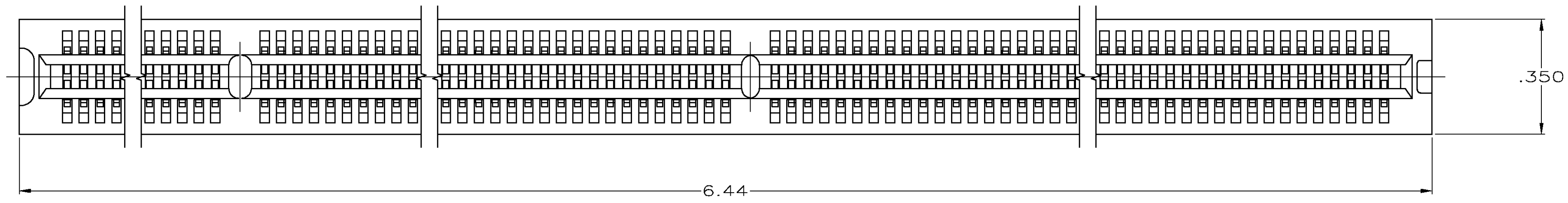

- ① HOUSING: HIGH TEMPERATURE THERMOPLASTIC. COLOR: BROWN.
- ② CONTACT: PHOSPHOR BRONZE.
- ③ METAL HOLD DOWN: BRASS
- ④ CONTACT FINISH: .000100 MIN NICKEL ALL OVER.
.000030 MIN GOLD OVER NICKEL IN CONTACT AREA.
.000100 MIN MATTE TIN OVER NICKEL ON SOLDER TAILS.
- ⑤ METAL HOLD DOWN FINISH: .000050 MIN NICKEL ALL OVER.
.000150 MIN MATTE TIN OVER NICKEL ALL OVER.
- ⑥ DISTANCE FROM CONTACT POINT TO BOTTOM OF CARD SLOT.
- ⑦ AMP PART NUMBER, DATE CODE AND CSA LOGO MARKED IN APPROXIMATE AREA SHOWN.

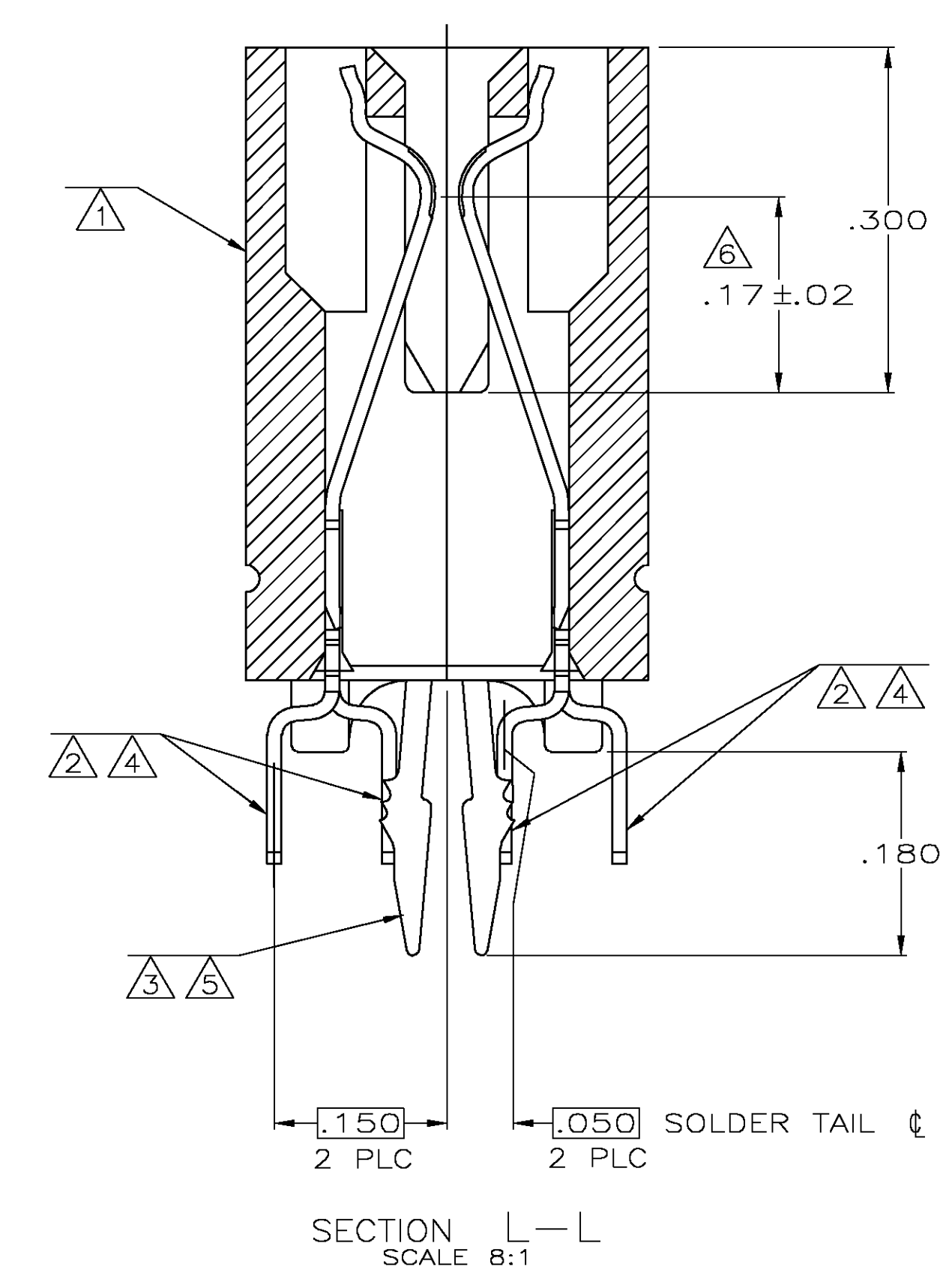

SEE SHEET 2 FOR HOLE PATTERN

.14	5145031-3
W	PART NUMBER

THIS DRAWING IS A CONTROLLED DOCUMENT.		DRN AL FRANTUM 22 JUN 05		Tyco Electronics Corporation Harrisburg, Pa 17105-3608	
DIMENSIONS: INCHES		CHK AL FRANTUM 22 JUN 05		NAME	
TOLERANCES UNLESS OTHERWISE SPECIFIED:		APVD	PRODUCT SPEC		
0 PLC ± -		108-14034		APPLICATION SPEC	
1 PLC ± .01		114-26012		RESTRICTED TO	
2 PLC ± .005		A1 00779		C=5145031	
3 PLC ± .005		CUSTOMER DRAWING		SCALE 4:1 SHEET 1 OF 2 REV 0	
4 PLC ± .005					
ANGLES ± 2					
FINISH					

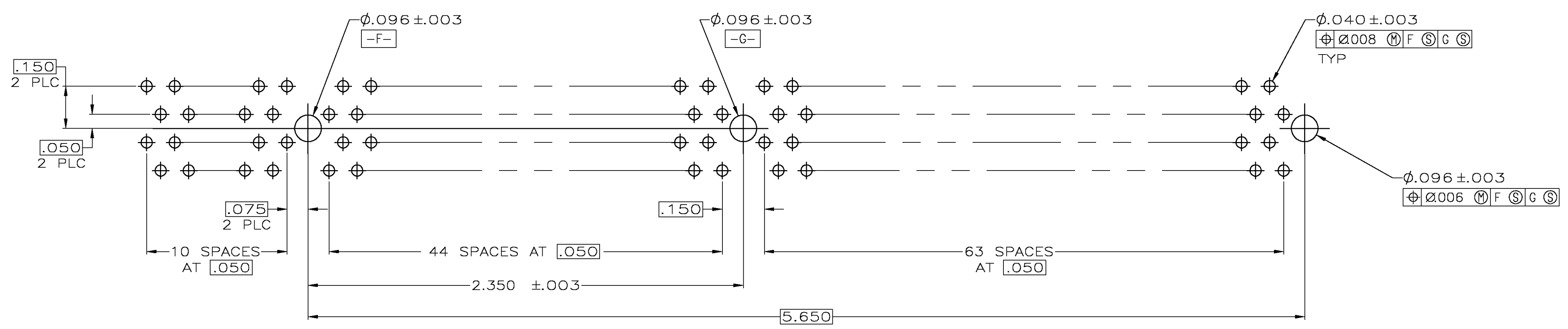

RECOMMENDED CONNECTOR MOUNTING HOLE PATTERN
 (CONNECTOR SIDE SHOWN)

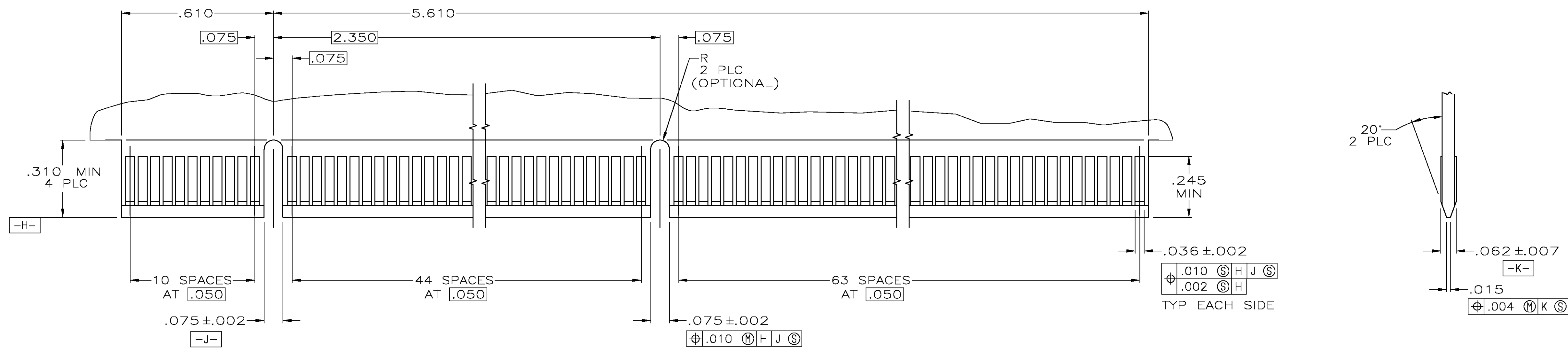

RECOMMENDED MATING BOARD EDGE CONFIGURATION

THIS DRAWING IS A CONTROLLED DOCUMENT.		DWN AL FRANTUM 22 JUN 05	 Tyco Electronics Corporation Harrisburg, Pa 17105-3608
DIMENSIONS: INCHES		CHK AL FRANTUM 22 JUN 05	
TOLERANCES UNLESS OTHERWISE SPECIFIED:		APVD	NAME
0 PLC ± - 1 PLC ± - 2 PLC ± .01 3 PLC ± .005 4 PLC ± - ANGLES ± - Z		PRODUCT SPEC 108-14034	CONNECTOR ASSEMBLY, 120 DUAL POSITION, .050 SERIES,
MATERIAL SEE SHEET 1		FINISH SEE SHEET 1	SIZE A1
		WEIGHT -	CAGE CODE 00779
			DRAWING NO 5145031
			RESTRICTED TO -
			CUSTOMER DRAWING
			SCALE 4:1 SHEET 2 OF 2 REV 0