



Chipsmall Limited consists of a professional team with an average of over 10 year of expertise in the distribution of electronic components. Based in Hongkong, we have already established firm and mutual-benefit business relationships with customers from,Europe,America and south Asia,supplying obsolete and hard-to-find components to meet their specific needs.

With the principle of “Quality Parts,Customers Priority,Honest Operation,and Considerate Service”,our business mainly focus on the distribution of electronic components. Line cards we deal with include Microchip,ALPS,ROHM,Xilinx,Pulse,ON,Everlight and Freescale. Main products comprise IC,Modules,Potentiometer,IC Socket,Relay,Connector.Our parts cover such applications as commercial,industrial, and automotives areas.

We are looking forward to setting up business relationship with you and hope to provide you with the best service and solution. Let us make a better world for our industry!



## Contact us

Tel: +86-755-8981 8866 Fax: +86-755-8427 6832

Email & Skype: info@chipsmall.com Web: www.chipsmall.com

Address: A1208, Overseas Decoration Building, #122 Zhenhua RD., Futian, Shenzhen, China



- ① HOUSING MATERIAL: GLASS-FILLED POLYMER.
- ② CONTACT MATERIAL: COPPER ALLOY.
- ③ PART NUMBER AND DATE CODE, IN THIS APPROXIMATE AREA, ON REVERSE SIDE.
- ④ ACTION PIN POSTS REQUIRE 1.57[.062] MINIMUM THICK PC BOARD. RECOMMENDED PC BOARD DRILLED HOLES ARE 1.15±0.025[.0453±0.010] DIAMETER WITH 0.02-0.08[.001-.003] COPPER AND 0.008[.0003] MINIMUM TIN-LEAD PLATING. FINISHED HOLE AFTER PLATING IS 0.94-1.09[.037-.043] DIAMETER.
- ⑤ CONTACT FINISH: DIN 41612 CLASS 2 IN CONTACT AREA. TIN PLATE ON POSTS.
- ⑥ TAIL LENGTH AFTER SEATING IN PC BOARD.
- ⑦ MARKING ON THIS SIDE.
- ⑧ CONTACT POINT AFTER SEATED IN PC BOARD.

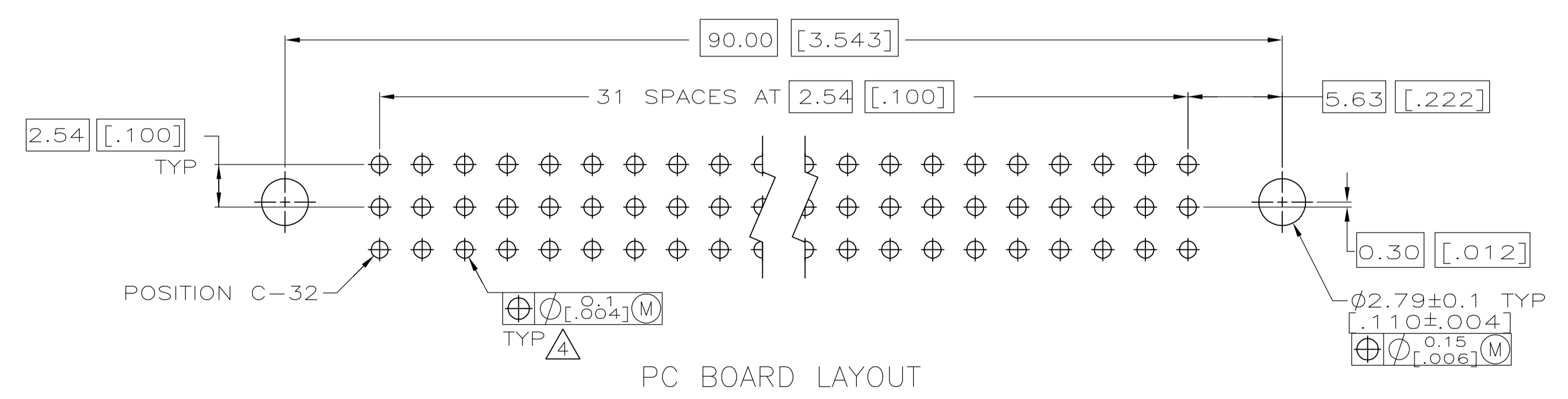
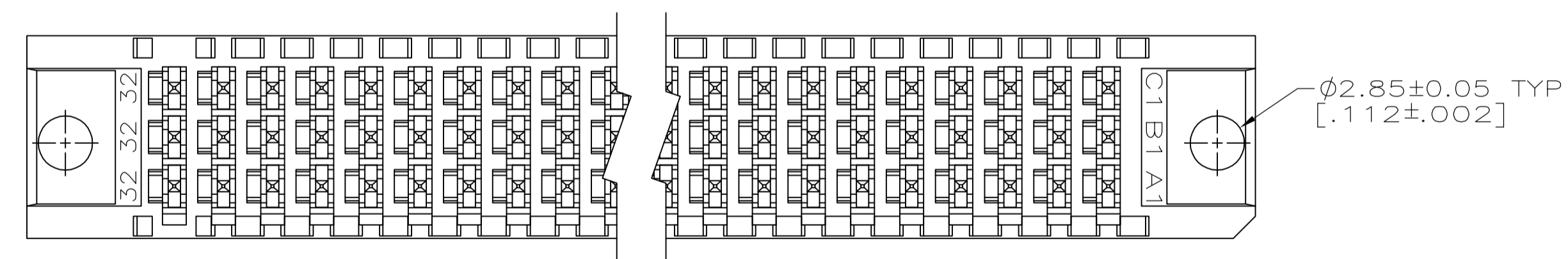
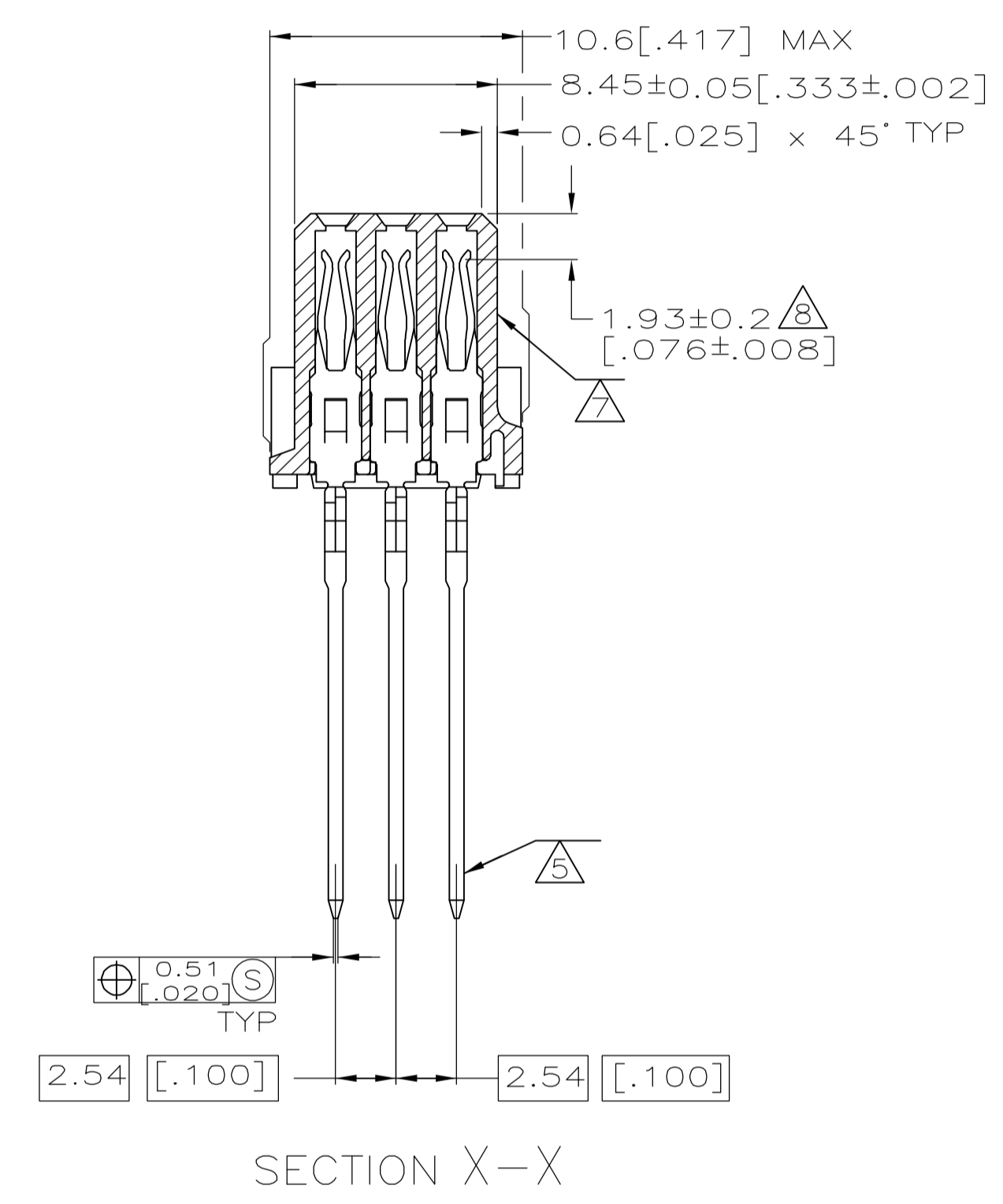
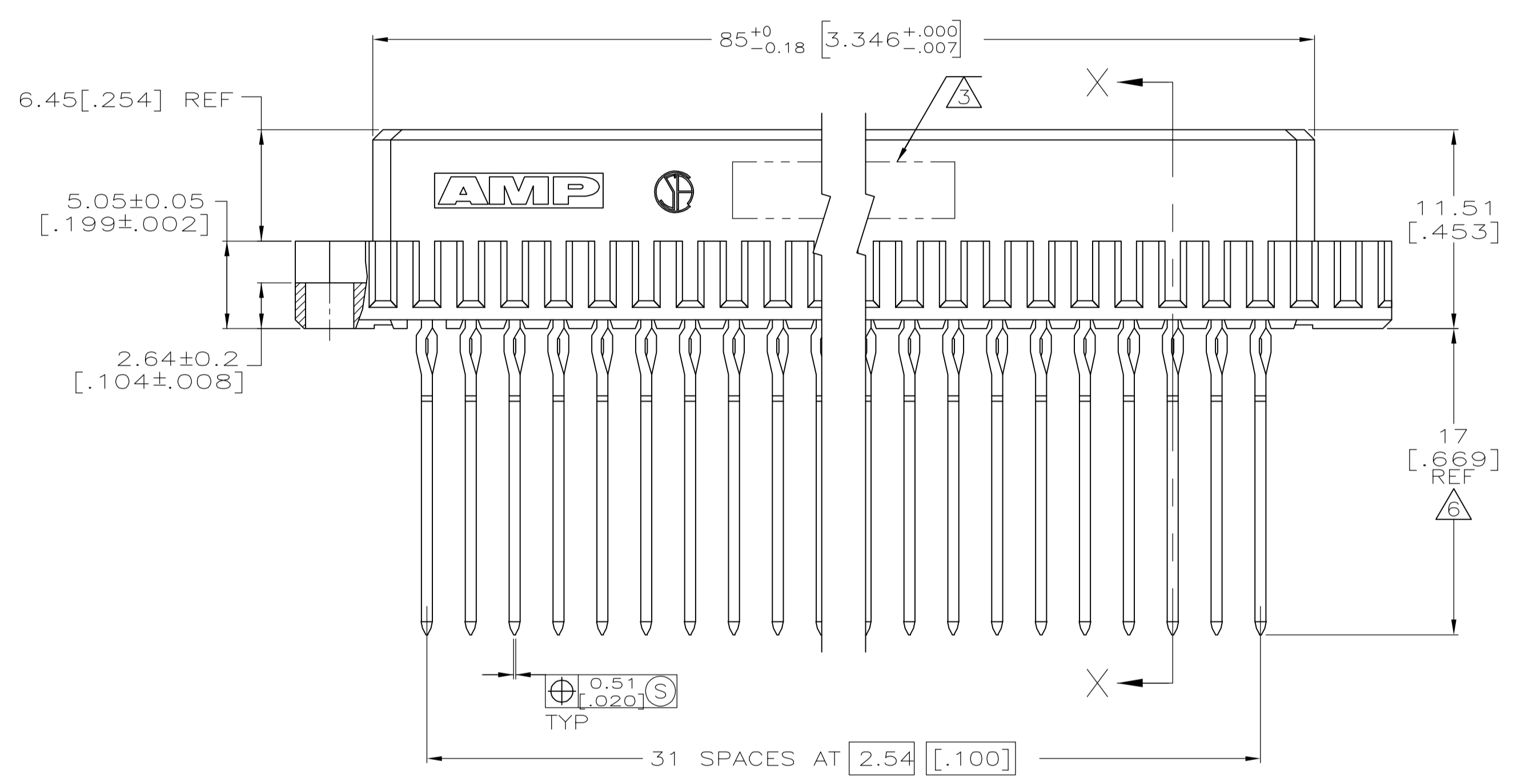
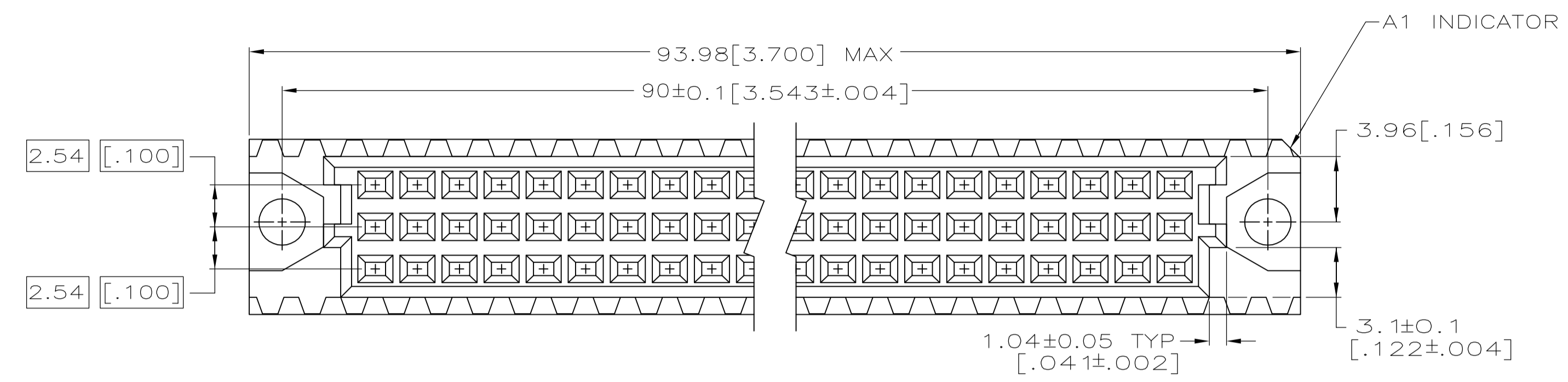

5148059-5  
PART NO

THIS DRAWING IS A CONTROLLED DOCUMENT.		DIN J. POLIGNONE 03JUN05		Tyco Electronics Corporation Harrisburg, PA 17105-3608	
DIMENSIONS: mm [INCHES]		CHK A. SHARPE 03JUN05		NAME	ASSEMBLY, RECEPTACLE, EUROCARD, TYPE C 96 POSITION, 18.06[.711] PRESS-FIT
TOLERANCES UNLESS OTHERWISE SPECIFIED:		APVD A. SHARPE 03JUN05	PRODUCT SPEC	SIZE	CAGE CODE DRAWING NO
0 PLC ± -	1 PLC ± -	APPLICATION SPEC	RESTRICTED TO	A1	00779C=5148059
2 PLC ± 0.13[.005]	3 PLC ± -	WEIGHT	CUSTOMER DRAWING	SCALE	4:1
4 PLC ± -	ANGLES ± 0° 30'			SHEET	1 OF 1
				REV	0