



Chipsmall Limited consists of a professional team with an average of over 10 year of expertise in the distribution of electronic components. Based in Hongkong, we have already established firm and mutual-benefit business relationships with customers from,Europe,America and south Asia,supplying obsolete and hard-to-find components to meet their specific needs.

With the principle of "Quality Parts,Customers Priority,Honest Operation,and Considerate Service",our business mainly focus on the distribution of electronic components. Line cards we deal with include Microchip,ALPS,ROHM,Xilinx,Pulse,ON,Everlight and Freescale. Main products comprise IC,Modules,Potentiometer,IC Socket,Relay,Connector.Our parts cover such applications as commercial,industrial, and automotives areas.

We are looking forward to setting up business relationship with you and hope to provide you with the best service and solution. Let us make a better world for our industry!



Contact us

Tel: +86-755-8981 8866 Fax: +86-755-8427 6832

Email & Skype: info@chipsmall.com Web: www.chipsmall.com

Address: A1208, Overseas Decoration Building, #122 Zhenhua RD., Futian, Shenzhen, China



Dialight

NEW!



Optopipe® Vertical Lightpipes

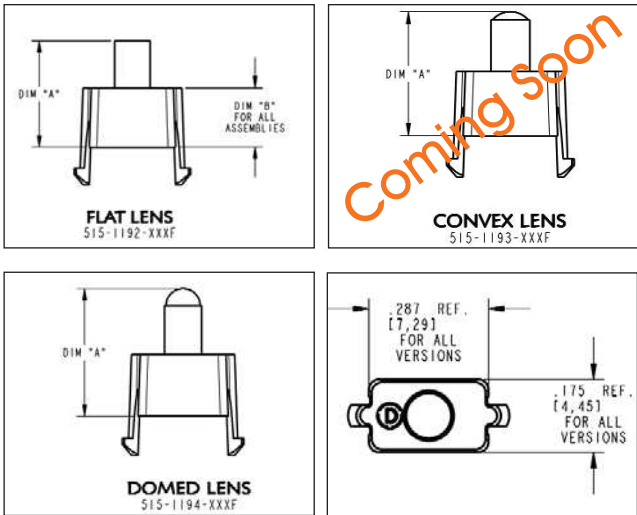

Features & Benefits:

- ▷ Six lengths varying from .250 to .550
- ▷ Three lens styles for optimal viewing angles; Flat, Domed, and Convex
- ▷ Designed for both single and multi-color LEDs
- ▷ Impervious to failure due to shock and vibration
- ▷ Up to 90% more efficient than traditional light sources when delivering monochromatic light
- ▷ Low-voltage and minimal power consumption
- ▷ Light is produced through photonic emission, not as a by-product of a radiating heat source
- ▷ Molded from RoHS compliant UL94-V0 Water Clear Polycarbonate with an oxygen index of 35%.
- ▷ Designed to be used with Dialight surface mount LEDs 597-XXXX-207F. See page 17 for LED operating characteristics

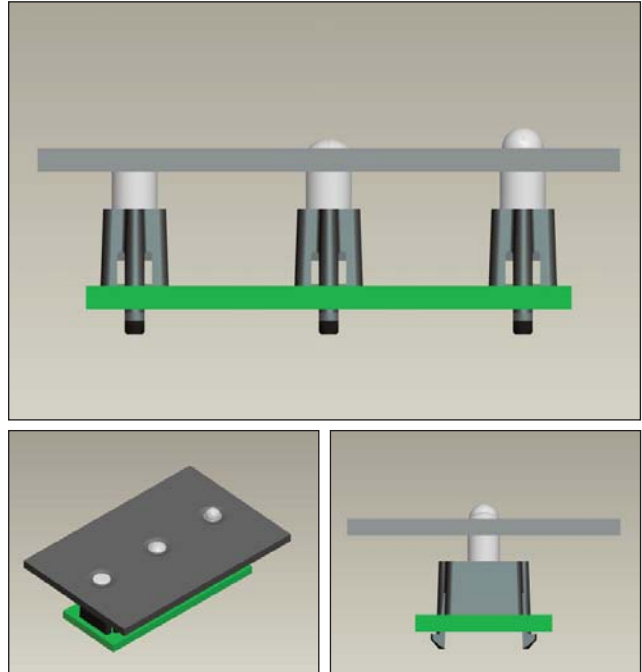

515-119 X-XXXX-F

Length in (mm)
see dim A
Lens Shape

Order Codes

Part Number	DIM "A" in (mm)	Lens Shape
515-1192-0250F	250 (6,35)	Flat
515-1192-0550F	550 (13,97)	Flat
515-1194-0300F	300 (7,62)	Domed
515-1194-0350F	350 (8,89)	Domed
515-1194-0354F	354 (8,99)	Domed
515-1194-0450F	450 (11,43)	Domed

Longer versions available on request, consult factory

