



Chipsmall Limited consists of a professional team with an average of over 10 year of expertise in the distribution of electronic components. Based in Hongkong, we have already established firm and mutual-benefit business relationships with customers from,Europe,America and south Asia,supplying obsolete and hard-to-find components to meet their specific needs.

With the principle of "Quality Parts,Customers Priority,Honest Operation,and Considerate Service",our business mainly focus on the distribution of electronic components. Line cards we deal with include Microchip,ALPS,ROHM,Xilinx,Pulse,ON,Everlight and Freescale. Main products comprise IC,Modules,Potentiometer,IC Socket,Relay,Connector.Our parts cover such applications as commercial,industrial, and automotives areas.

We are looking forward to setting up business relationship with you and hope to provide you with the best service and solution. Let us make a better world for our industry!



## Contact us

Tel: +86-755-8981 8866 Fax: +86-755-8427 6832

Email & Skype: info@chipsmall.com Web: www.chipsmall.com

Address: A1208, Overseas Decoration Building, #122 Zhenhua RD., Futian, Shenzhen, China



THIS DRAWING IS UNPUBLISHED. RELEASED FOR PUBLICATION  
 © COPYRIGHT - BY - ALL RIGHTS RESERVED.

LOC DY	DIST -	REVISIONS		
P	LTR	DESCRIPTION	DATE	DWN RK
		B1 REVISED PER ECO-11-005139	19MAR11	APVD HMR

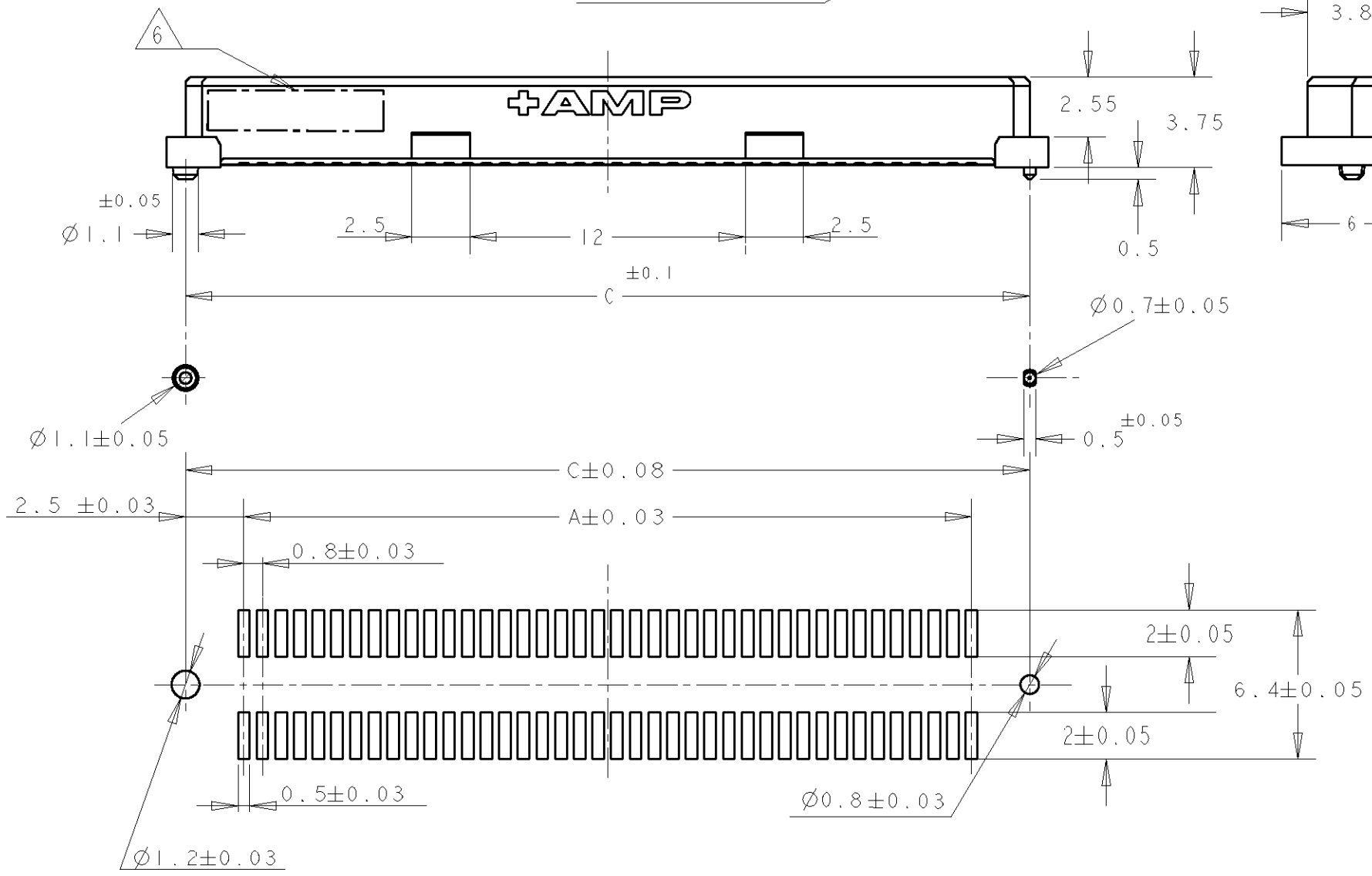
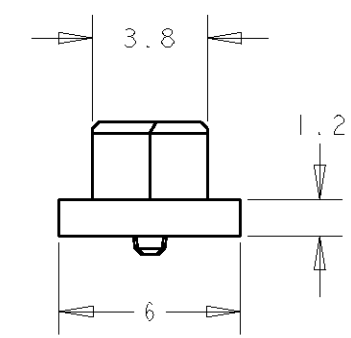
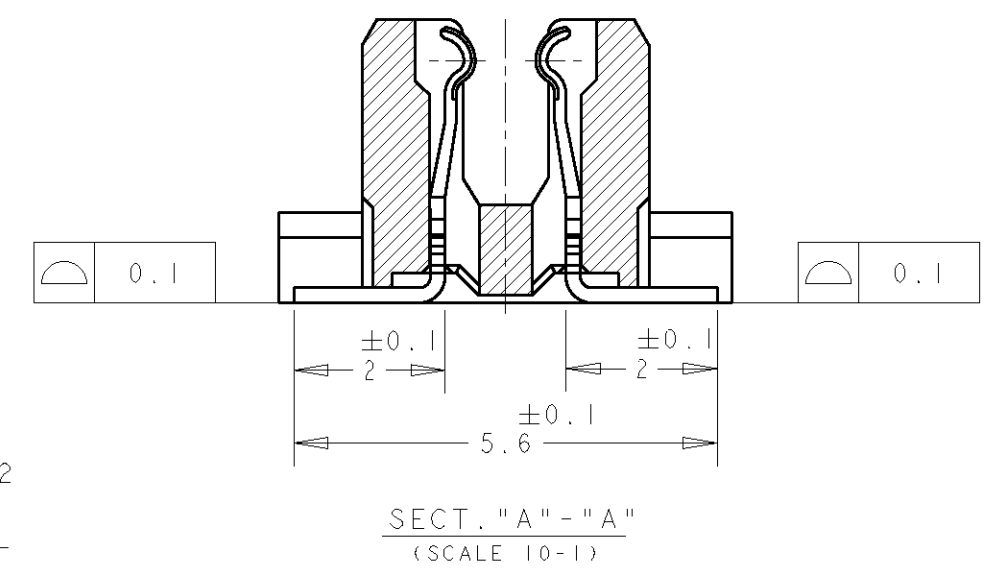
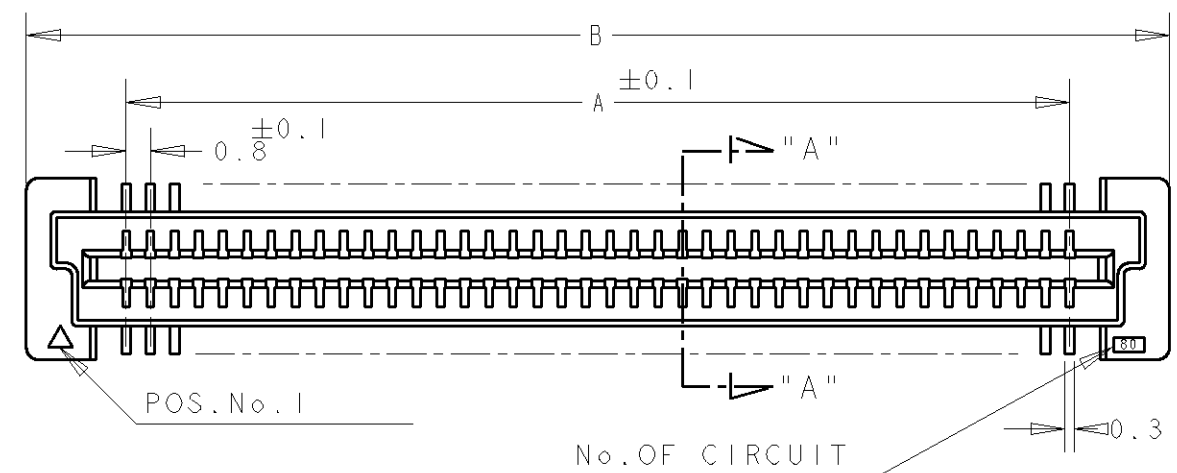

NOTES:

- 1. MATERIAL: HOUSING: L.C.P (HIGH TEMP THERMOPLASTIC) UL 94V-0, NATURAL. CONTACT: COPPER ALLOY.
- 2. FINISH: CONTACT AREA: 0.0002 MIN GOLD ON 0.0013 MIN ALL OVER NICKEL. SOLDERING AREA: 0.002 MIN MATTE TIN.
- 3. POSITION SERIES: SEE TABLE.
- 4. CONN STACK HEIGHT COMBINE OF PLUG "Y" H VS REC "X" H. STACK HEIGHT = Y + X - 5
- 5. FINISH: CONTACT AREA: 0.00038 MIN GOLD ON 0.0013 MIN ALL OVER NICKEL. SOLDERING AREA: 0.002 MIN MATTE TIN.
- 6. DATE CODE MARKING.

P/N SEE SHEET 2 OF 2.

RECOMMENDED P.C. BOARD LAYOUT

DOWNSIDE: SK LEAW 17MAY2004		TE Connectivity	
CHECKED: ERIC TNG			
APPROVED: SEIFONG		NAME: RECEPTACLE ASSEMBLY 5H TYPE (0.5 BOSS LENGTH) FOR FH0.8MM PITCH B-T-B CONNECTOR	
DIMENSIONS: mm		PRODUCT SPEC: 108-5390	
TOLERANCES UNLESS OTHERWISE SPECIFIED:		APPLICATION SPEC: 114-5254	
0 PLC ±0.3		WEIGHT: -	
1 PLC ±0.25		SIZE: A3	
2 PLC ±0.2		CAGE CODE: 00779	
3 PLC ±0.2		DRAWING NO: C=5177983	
4 PLC ±0.2		SCALE: 4:1	
ANGLES ±3°		SHEET: 1 OF 2	
MATERIAL: SEE P/N TABLE		REV: B1	
FINISH: SEE P/N TABLE		CUSTOMER DRAWING	

THIS DRAWING IS UNPUBLISHED. RELEASED FOR PUBLICATION  
 © COPYRIGHT BY ALL RIGHTS RESERVED.

LOC DY	DIST -	REVISIONS		
P	LTR	DESCRIPTION	DATE	DWN -
		SEE SHEET 1 OF 2	-	APVD -

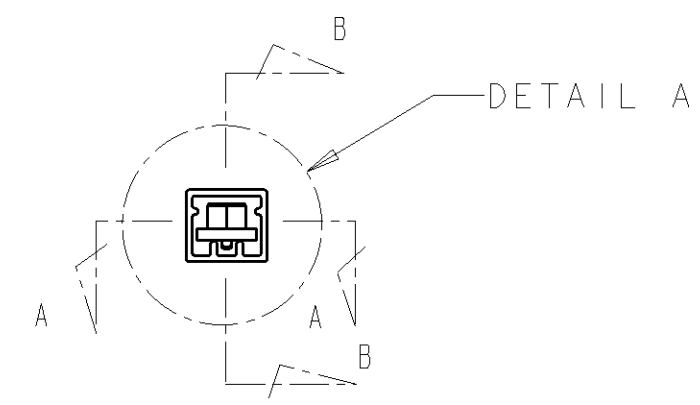
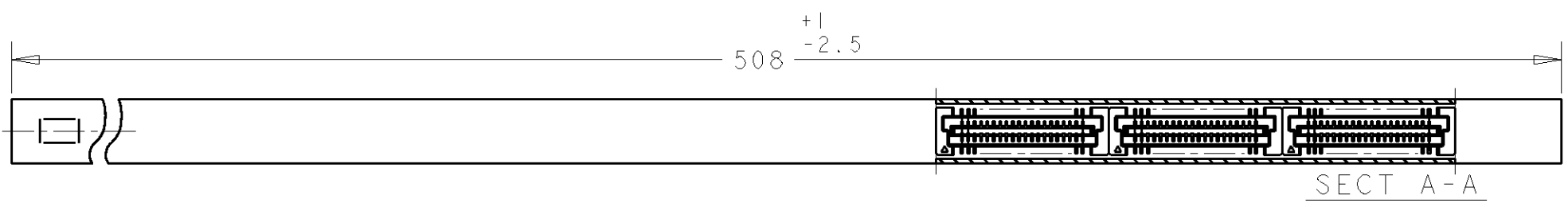

REFERENCE PICTURE OF TUBE PACK

SECT B-B

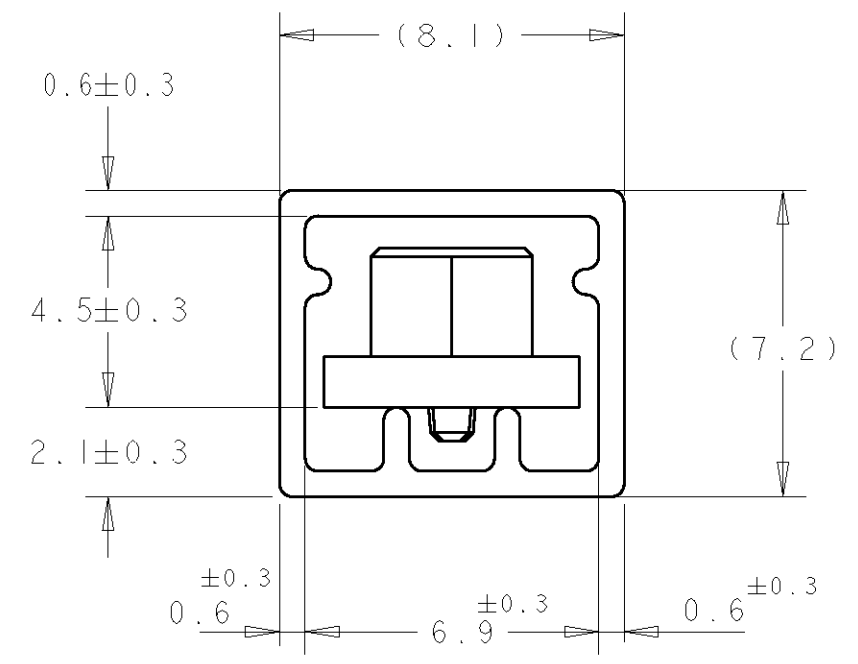

DETAIL A

5	5	84.2	85.8	79.2	200	2-	-0
	6	76.2	77.8	71.2	180	1-	-9
	6	68.2	69.8	63.2	160	1-	-8
	7	60.2	61.8	55.2	120	1-	-6
	9	52.2	53.8	47.2	120	1-	-5
	10	44.2	45.8	39.2	100	1-	-4
	12	36.2	37.8	31.2	80	1-	-3
	16	28.2	29.8	23.2	60	1-	-2
	22	20.2	21.8	15.2	40	1-	-1
	2	5	84.2	85.8	79.2	200	1-
6		76.2	77.8	71.2	180		-9
6		68.2	69.8	63.2	160		-8
7		60.2	61.8	55.2	140		-6
9		52.2	53.8	47.2	120		-5
10		44.2	45.8	39.2	100		-4
	12	36.2	37.8	31.2	80		-3
	16	28.2	29.8	23.2	60		-2
	22	20.2	21.8	15.2	40		-1
FINISH	QTY	C	B	A	POS	CONN P/N	

DWN SK LEAW 17MAY2004		TE Connectivity	
CHK ERIC TNG		NAME RECEPTACLE ASSEMBLY 5H TYPE	
APVD SEIFONG		(0.5 BOSS LENGTH) FOR FH0.8MM PITCH	
PRODUCT SPEC 108-5390		B-T-B CONNECTOR	
APPLICATION SPEC 114-5254		SIZE A3	CAGE CODE 00779
MATERIAL SEE NOTE 1		DRAWING NO C=5177983	
FINISH SEE P/N TABLE		SCALE -	SHEET 2 OF 2
CUSTOMER DRAWING		REV B1	