



Chipsmall Limited consists of a professional team with an average of over 10 year of expertise in the distribution of electronic components. Based in Hongkong, we have already established firm and mutual-benefit business relationships with customers from,Europe,America and south Asia,supplying obsolete and hard-to-find components to meet their specific needs.

With the principle of "Quality Parts,Customers Priority,Honest Operation,and Considerate Service",our business mainly focus on the distribution of electronic components. Line cards we deal with include Microchip,ALPS,ROHM,Xilinx,Pulse,ON,Everlight and Freescale. Main products comprise IC,Modules,Potentiometer,IC Socket,Relay,Connector.Our parts cover such applications as commercial,industrial, and automotives areas.

We are looking forward to setting up business relationship with you and hope to provide you with the best service and solution. Let us make a better world for our industry!



## Contact us

Tel: +86-755-8981 8866 Fax: +86-755-8427 6832

Email & Skype: info@chipsmall.com Web: www.chipsmall.com

Address: A1208, Overseas Decoration Building, #122 Zhenhua RD., Futian, Shenzhen, China



THIS DRAWING IS UNPUBLISHED. RELEASED FOR PUBLICATION SEP, 2004.  
 © COPYRIGHT 2004 BY TYCO ELECTRONICS CORPORATION. ALL INTERNATIONAL RIGHTS RESERVED.

LOC	DIST	REVISIONS			DATE	DWN	APVD
J	/	P	LTR	DESCRIPTION			
		A		REVISED ECR-09-015097	05OCT09	T.T	T.M

-1: AS SHOWN

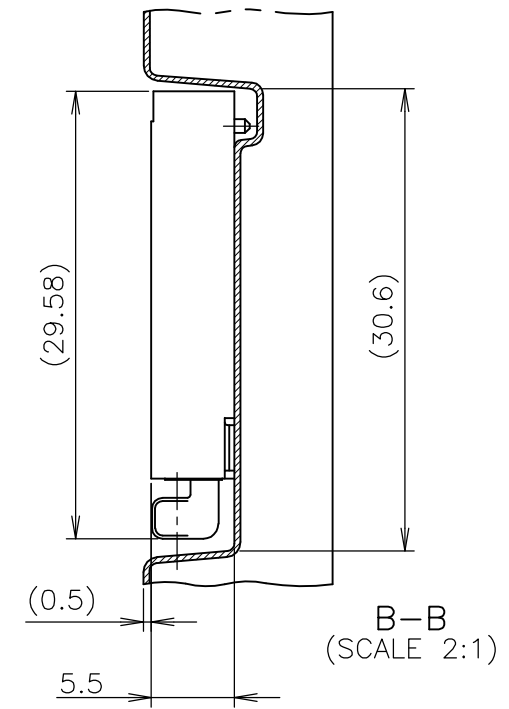
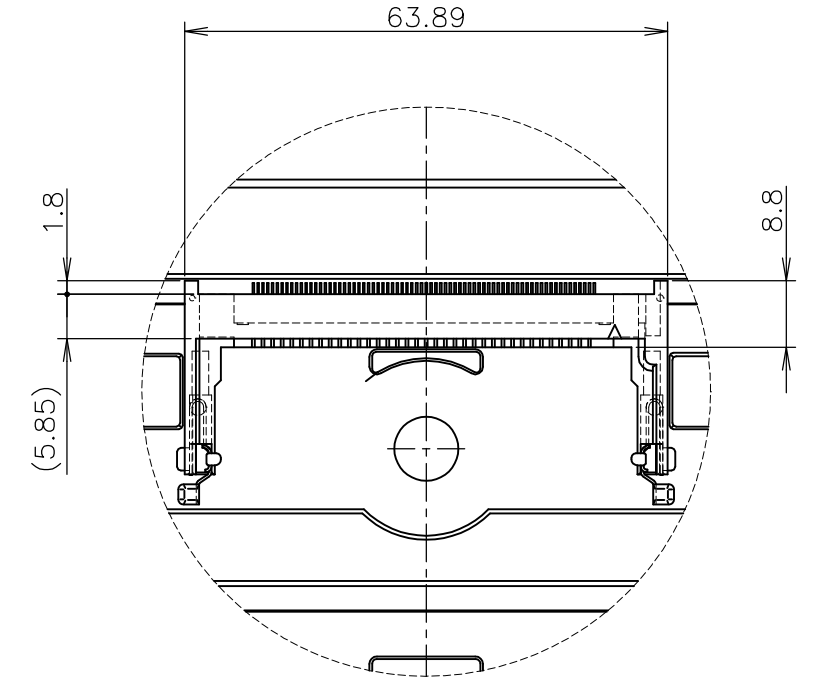
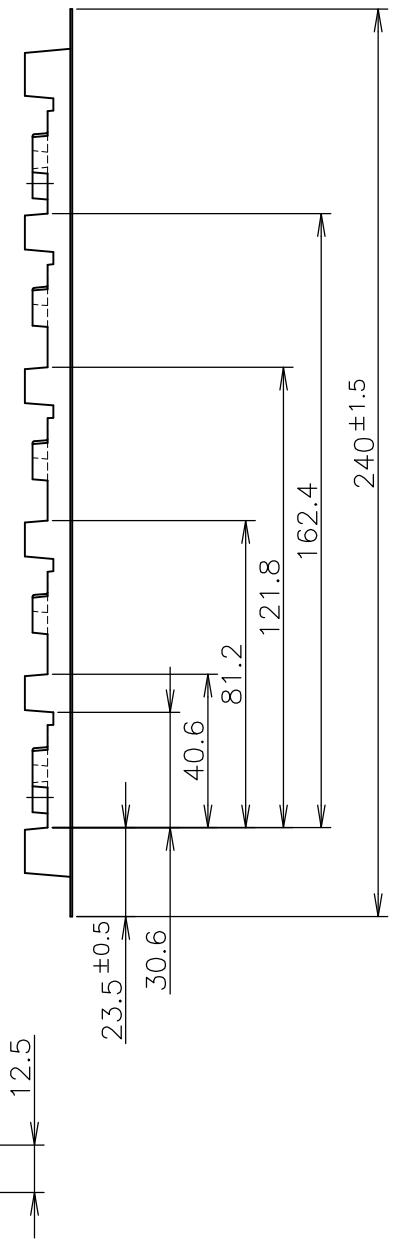
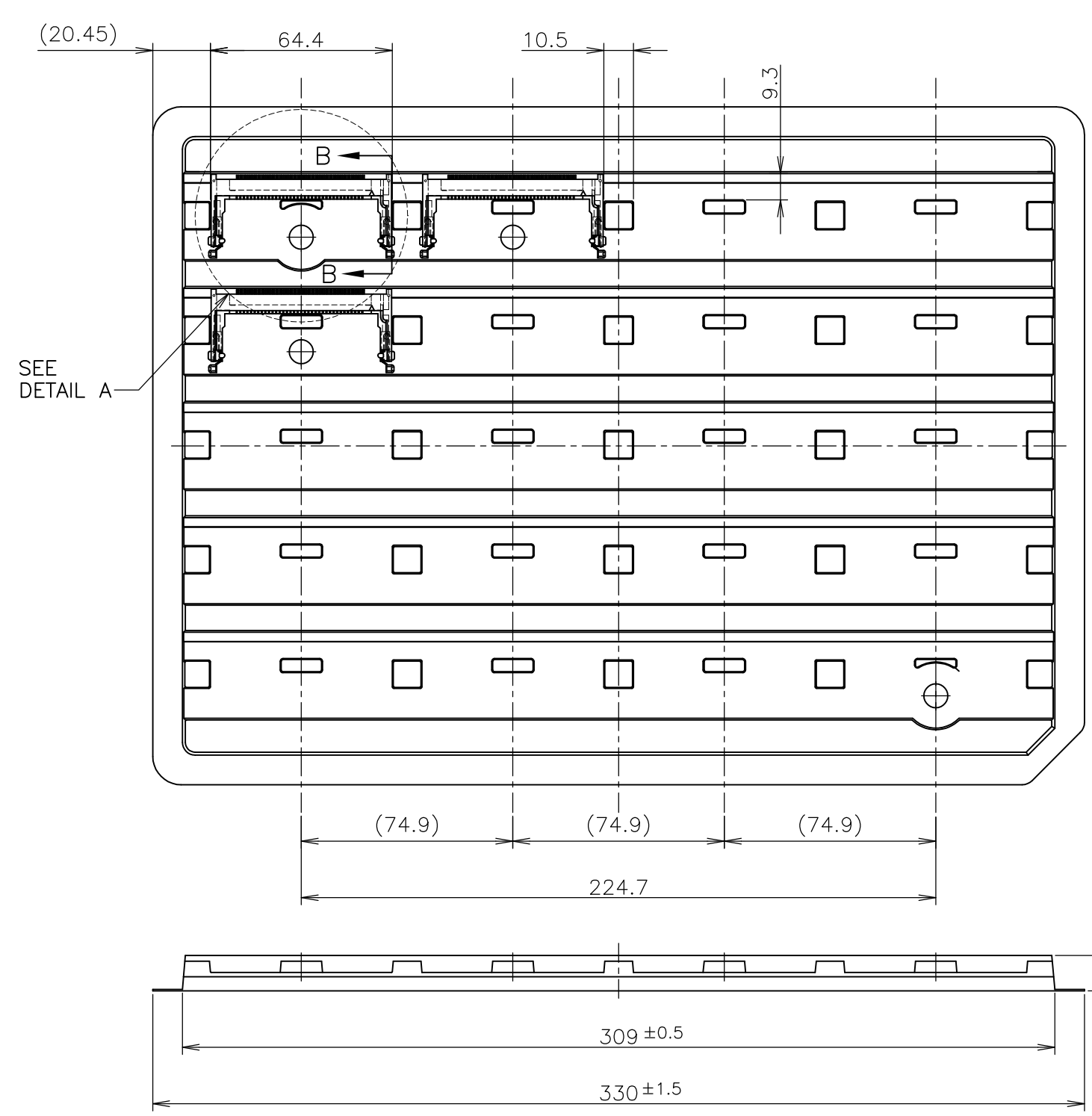

THIS DRAWING IS A CONTROLLED DOCUMENT.		DWN T.KAWAMAE 24SEP2004	Tyco Electronics Corporation Kawasaki, Japan	
DIMENSIONS: 単位: 耗 mm		CHK I.ENOMOTO 24SEP2004	NAME 名称	
TOLERANCES UNLESS OTHERWISE SPECIFIED: 一般公差		APVD I.ENOMOTO 24SEP2004	SEMI HARD TRAY ASSY MIII SOCKET 72 POS	
0 PLC ± - 1 PLC ± - 2 PLC ± - 3 PLC ± - 4 PLC ± - ANGLES ± -		PRODUCT SPEC 製品規格 108-5403	SIZE A3	CAGE CODE 00779
GENERAL TOLERANCE 一般公差		APPLICATION SPEC 取付適用規格	DRAWING NO 番号 G-5179707	RESTRICTED TO 番号
10 ≥ : ±0.2 30 ≥ > 10: ±0.25 100 ≥ > 30: ±0.3 ANGLES: ±3'		WEIGHT	SCALE 尺度 1:2	SHEET 1 OF 3
MATERIAL 材料	FINISH 仕上	CUSTOMER DRAWING		REV A

REMARKS	QTY	POS	PART NO.
3.3V, Au PL.	20	72	5179707-1

THIS DRAWING IS UNPUBLISHED. RELEASED FOR PUBLICATION SEP. 2004.  
 © COPYRIGHT 2004 BY TYCO ELECTRONICS CORPORATION. ALL INTERNATIONAL RIGHTS RESERVED.

LOC	DIST	REVISIONS					
J	/	P	LTR	DESCRIPTION	DATE	DWN	APVD
		-		SEE SHEET 1	-	-	-

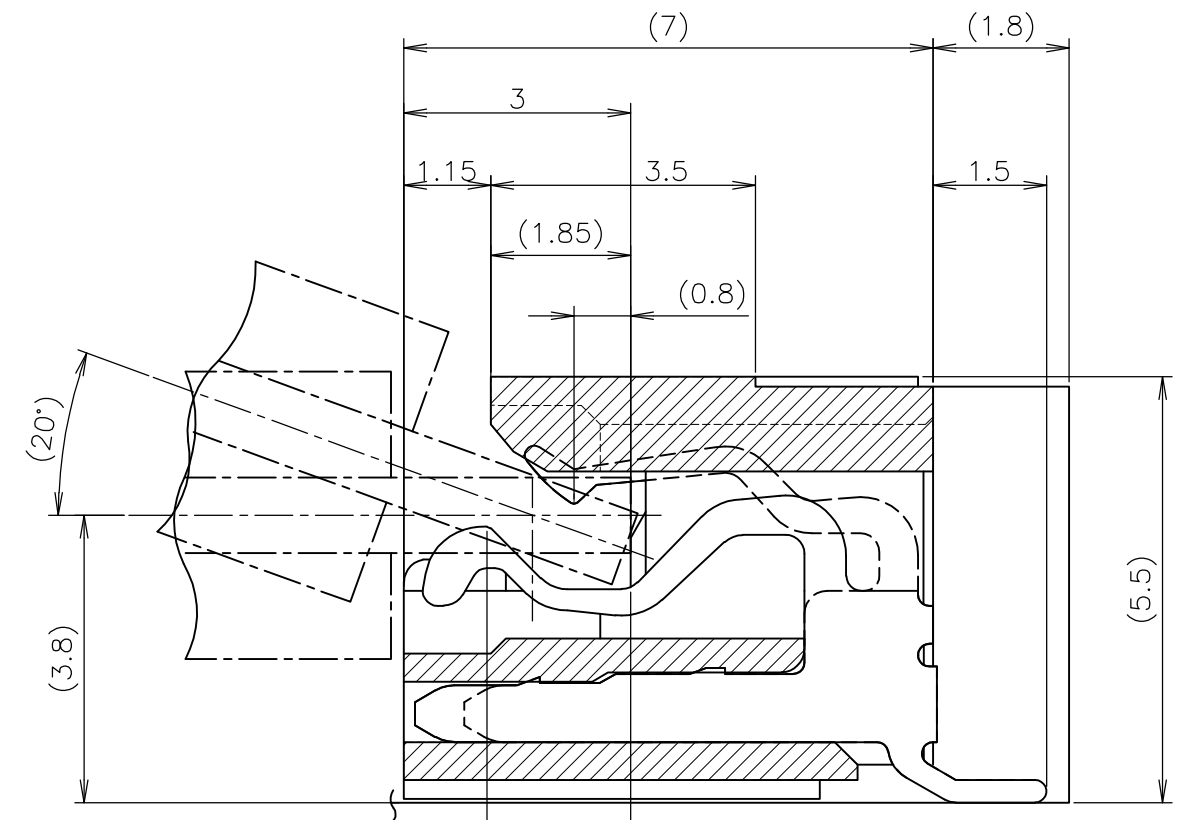
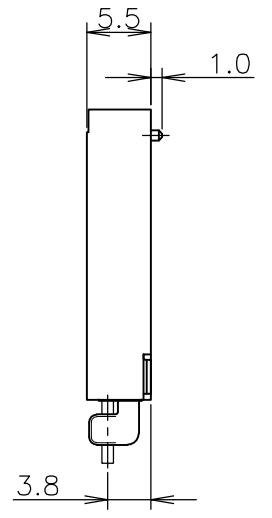
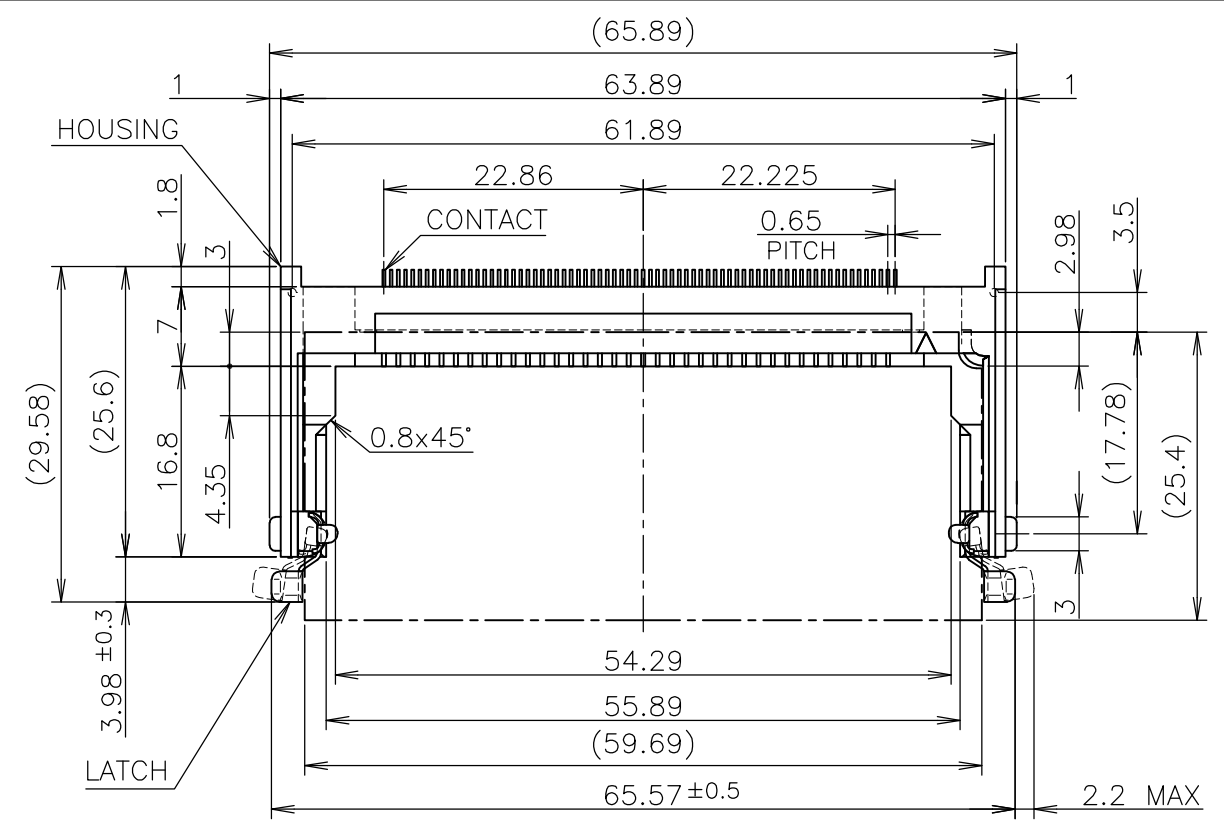

D-D  
(SCALE 10:1)

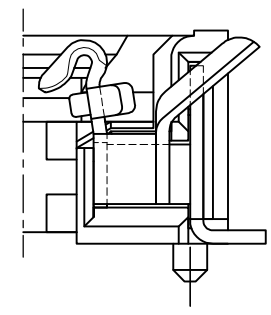
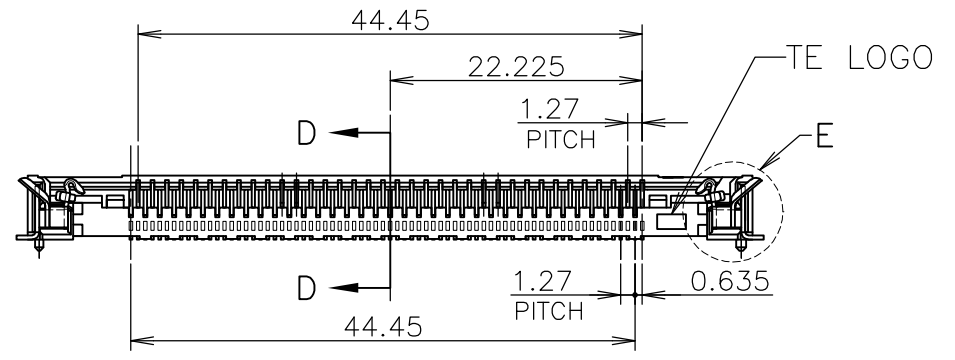

DETAIL E  
(SCALE 5:1)

- 1 MATERIAL & FINISH  
 HOUSING: GLASS FILLED LCP, NATURAL  
 CONTACT: COPPER ALLOY  
 FINISH...SEE NOTES  
 LATCH: COPPER ALLOY. TIN PL.  
 CONTACT PLATING (Au PL. TYPE)  
 Au (0.3um) PL. AT CONTACT,  
 TIN PL. AT TINE OVER Ni PL.  
 TOLERANCE: NON CUMULATIVE.

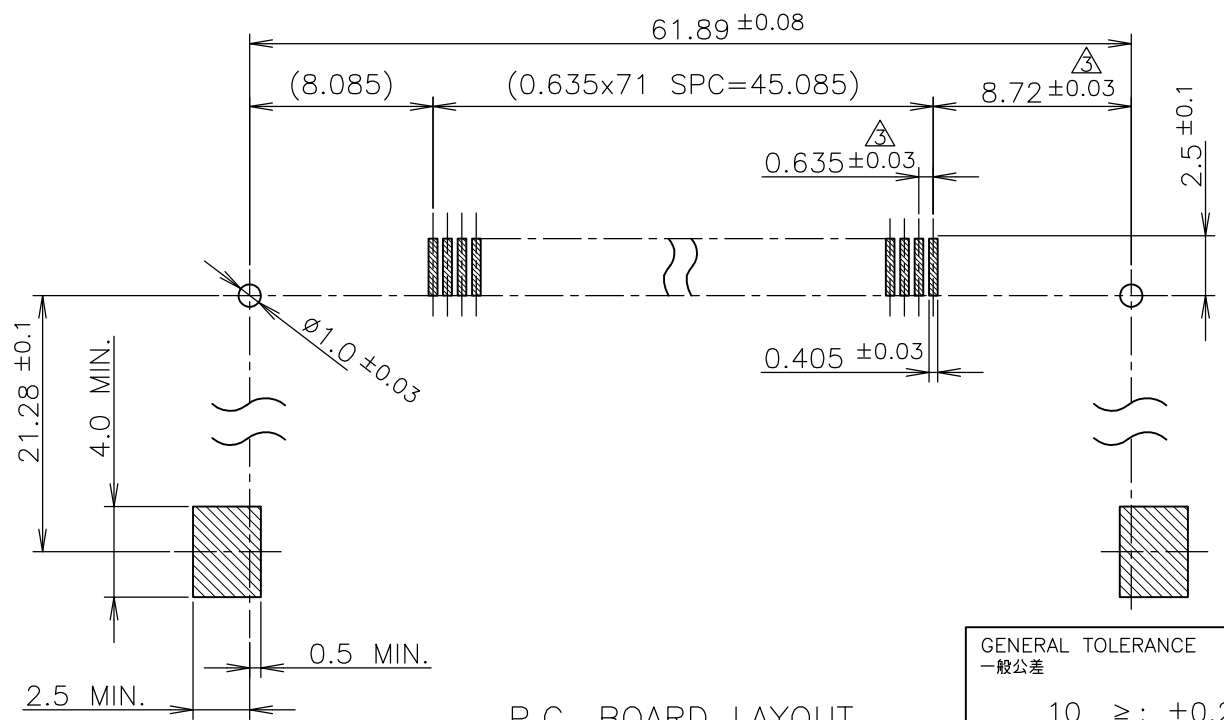

P.C. BOARD LAYOUT  
(CONNECTOR MOUNT SIDE)

GENERAL TOLERANCE  
一般公差

10 ≥	±0.2
30 ≥ > 10	±0.25
100 ≥ > 30	±0.3
ANGLES	±3°

THIS DRAWING IS A CONTROLLED DOCUMENT.		DWN		Tyco Electronics		Tyco Electronics Corporation	
DIMENSIONS: 単位: 耗 mm		TOLERANCES UNLESS OTHERWISE SPECIFIED: 一般公差		NAME 名称		Kawasaki, Japan	
0 PLC ± -		1 PLC ± -		PRODUCT SPEC 製品規格		SEMI HARD TRAY ASSY	
2 PLC ± -		3 PLC ± -		APPLICATION SPEC 取付適用規格		MIII SOCKET 72 POS	
4 PLC ± -		ANGLES ± -		FINISH 仕上		SIZE	
MATERIAL 材料		CUSTOMER DRAWING		WEIGHT		CAGE CODE	
				A3		00779	
				DRAWING NO 番号		RESTRICTED TO	
				G-5179707		-	
				SCALE 尺度		SHEET	
				NTS		2 OF 3	
				REV		A	

THIS DRAWING IS UNPUBLISHED. RELEASED FOR PUBLICATION SEP, 2004.  
 © COPYRIGHT 2004 BY TYCO ELECTRONICS CORPORATION. ALL INTERNATIONAL RIGHTS RESERVED.

LOC	DIST	REVISIONS					
J	/	P	LTR	DESCRIPTION	DATE	DWN	APVD
		-		SEE SHEET 1	-	-	-

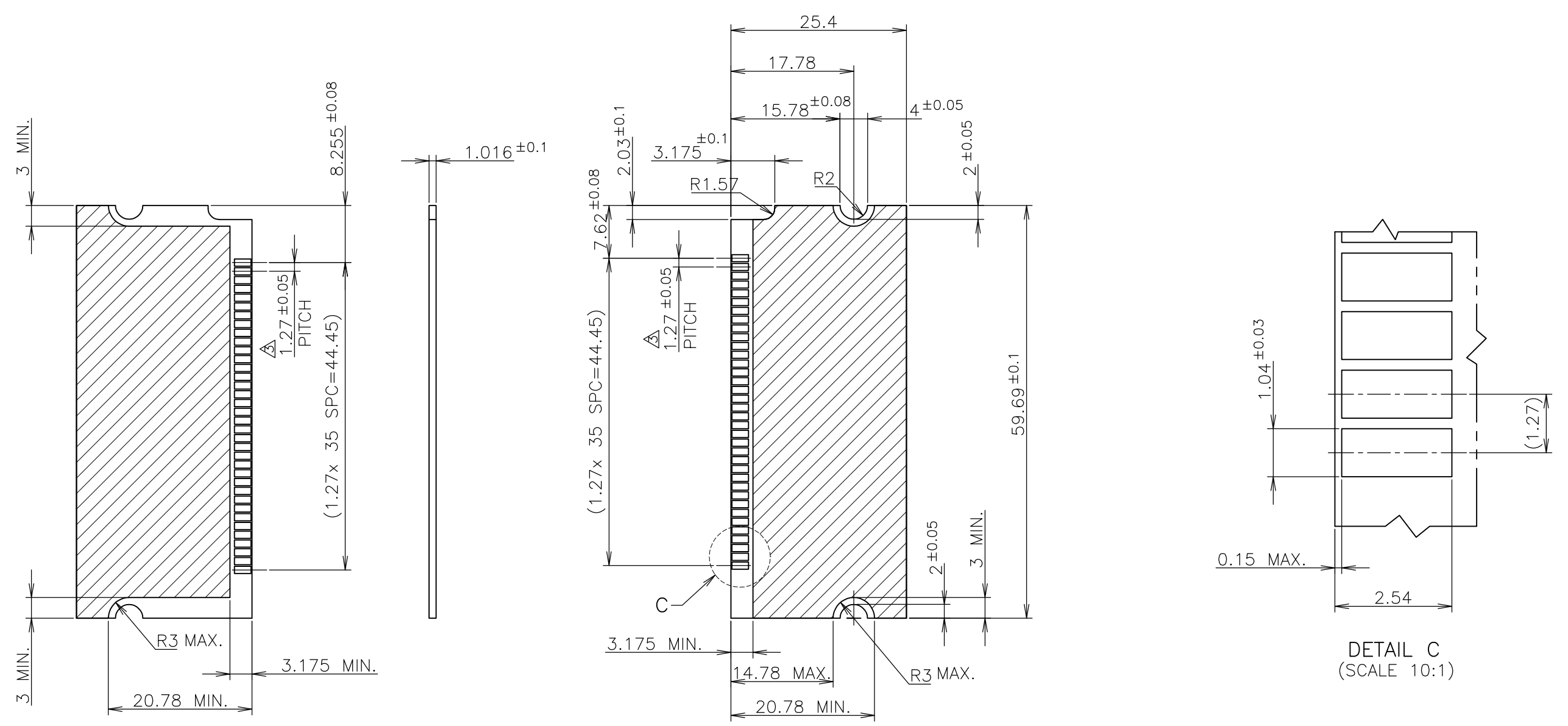

COMPONENT AREA

RECOMMENDED DIMENSIONS OF SMALL OUTLINE SIMM P.C. BOARD

GENERAL TOLERANCE  
 一般公差  
 10 ≥ : ±0.2  
 30 ≥ > 10: ±0.25  
 100 ≥ > 30: ±0.3  
 ANGLES: ±3°

THIS DRAWING IS A CONTROLLED DOCUMENT.		DWN		Tyco Electronics Corporation	
DIMENSIONS: 単位: 耗 mm		CHK		Tyco Electronics Kawasaki, Japan	
TOLERANCES UNLESS OTHERWISE SPECIFIED: 一般公差		APVD		NAME 名称	
0 PLC ± - 1 PLC ± - 2 PLC ± - 3 PLC ± - 4 PLC ± - ANGLES ± -		PRODUCT SPEC 製品規格 108-5403		SEMI HARD TRAY ASSY MIII SOCKET 72 POS	
MATERIAL 材料		FINISH 仕上		APPLICATION SPEC 取付適用規格	
		WEIGHT		SIZE CAGE CODE DRAWING NO 番号	
		CUSTOMER DRAWING		A3 00779 C-5179707	
		SCALE 尺度 NTS		RESTRICTED TO	
		SHEET 3 OF 3		REV A	