



Chipsmall Limited consists of a professional team with an average of over 10 year of expertise in the distribution of electronic components. Based in Hongkong, we have already established firm and mutual-benefit business relationships with customers from,Europe,America and south Asia,supplying obsolete and hard-to-find components to meet their specific needs.

With the principle of "Quality Parts,Customers Priority,Honest Operation,and Considerate Service",our business mainly focus on the distribution of electronic components. Line cards we deal with include Microchip,ALPS,ROHM,Xilinx,Pulse,ON,Everlight and Freescale. Main products comprise IC,Modules,Potentiometer,IC Socket,Relay,Connector.Our parts cover such applications as commercial,industrial, and automotives areas.

We are looking forward to setting up business relationship with you and hope to provide you with the best service and solution. Let us make a better world for our industry!



Contact us

Tel: +86-755-8981 8866 Fax: +86-755-8427 6832

Email & Skype: info@chipsmall.com Web: www.chipsmall.com

Address: A1208, Overseas Decoration Building, #122 Zhenhua RD., Futian, Shenzhen, China



NOTES:

1. SUGGESTED MOUNTING HOLE = $\phi.147 \pm .001$
2. MAX REFLOW IS 245°C FOR 5 SEC.

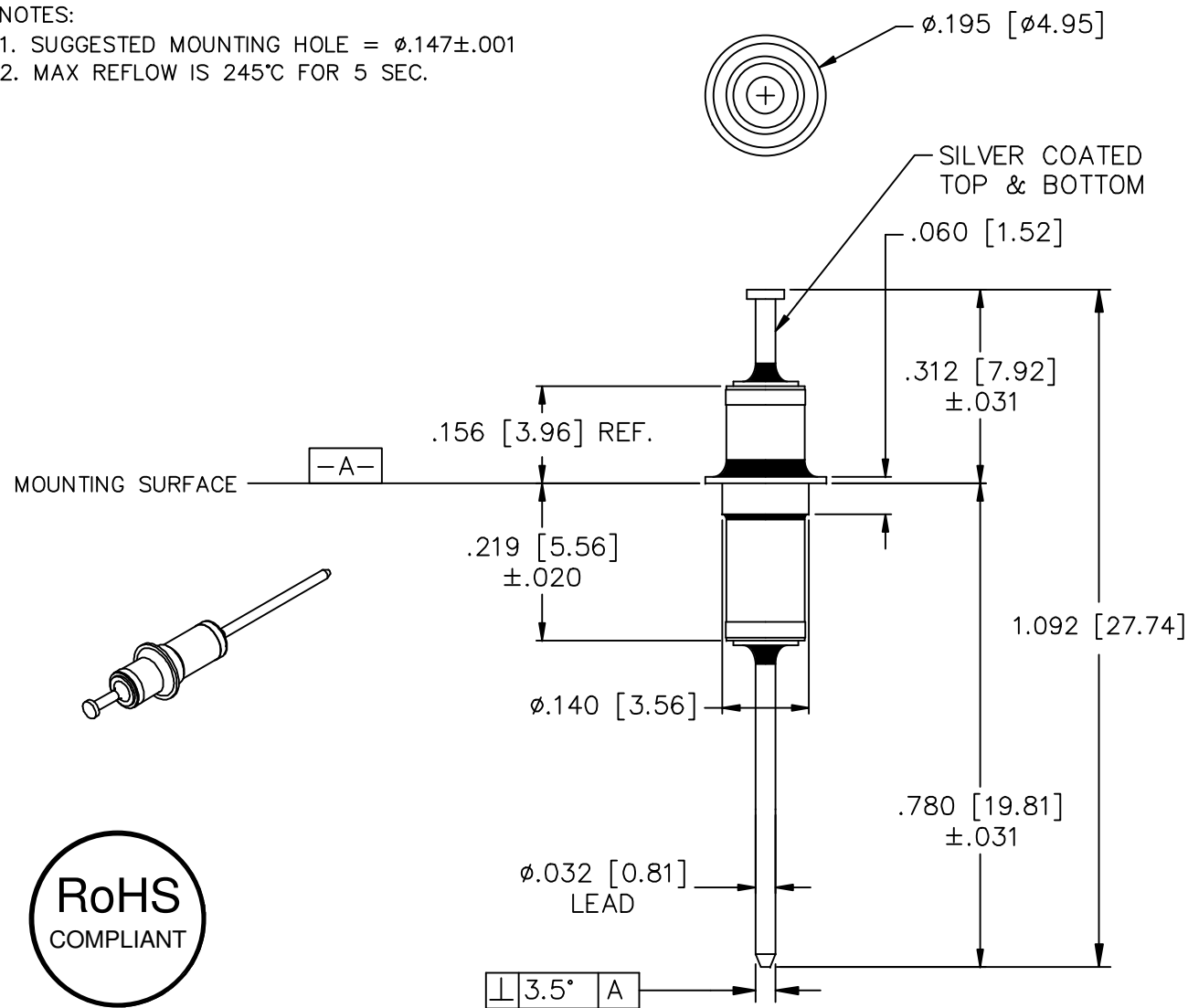

LEAD FINISH: SILVER	
EYELET FINISH: SILVER	
CAPACITANCE	22nF GMV
TEMP. RANGE	-55°C TO 125°C
CURRENT	10 AMP MAX.
WORKING VOLTAGE	85°C -- VDC MAX. 125°C 70 VDC MAX.
D.C. RESISTANCE	.01ohms MAX.
MIN. I.L. PER MIL-STD-220 AT 25°C NO LOAD	
FREQ. MHz	I.L. (db)
1	7
10	25
30	60
100	70
300	70
1 GHz	70

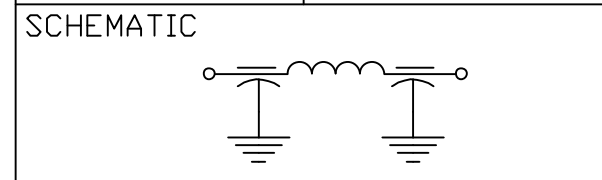

MARKING:
 PART: NONE
 BAG:
 51F-750-302
 DATE CODE
 QTY./BAG (200 MAX.)

									03										REV. N/D.	TOLERANCES UNLESS OTHERWISE SPECIFIED
									03										CHANGE NOTICE	Fractions $\pm 1/64$
									REDRAWN											Dec. .xx±
									CN #25162											Dec. .xxx±.005
									CN 30515-CPD	02										Angles $\pm 0^{\circ} 30'$
									CN 26049-CPD	01										CODE IDENT. NO. OLSP2
									CN 18049-CPD	00										

		FAIRVIEW PENNSYLVANIA	
Date 3-28-17	SOLDER MNT. FILTER		
ENGR. B.DEVINE	51F-750-302		
DO NOT SCALE			