



Chipsmall Limited consists of a professional team with an average of over 10 year of expertise in the distribution of electronic components. Based in Hongkong, we have already established firm and mutual-benefit business relationships with customers from,Europe,America and south Asia,supplying obsolete and hard-to-find components to meet their specific needs.

With the principle of “Quality Parts,Customers Priority,Honest Operation,and Considerate Service”,our business mainly focus on the distribution of electronic components. Line cards we deal with include Microchip,ALPS,ROHM,Xilinx,Pulse,ON,Everlight and Freescale. Main products comprise IC,Modules,Potentiometer,IC Socket,Relay,Connector.Our parts cover such applications as commercial,industrial, and automotives areas.

We are looking forward to setting up business relationship with you and hope to provide you with the best service and solution. Let us make a better world for our industry!



## Contact us

Tel: +86-755-8981 8866 Fax: +86-755-8427 6832

Email & Skype: info@chipsmall.com Web: www.chipsmall.com

Address: A1208, Overseas Decoration Building, #122 Zhenhua RD., Futian, Shenzhen, China



### GENERAL DESCRIPTION

The MTTC-1410 Thermoelectric Temperature Controller is a precision instrument that utilizes Pulse Width Modulation (PWM) control technology to provide accurate temperature control of thermoelectric devices. The MTTC-1410 is a bi directional controller with selectable voltage output and a full “H” bridge capable of load currents of up to ten amperes. The unit’s LED front control panel can be used to adjust the setpoint temperature, to view the current temperature, or to fine-tune the control parameters for higher accuracy or faster response.

### SPECIFICATIONS AND FEATURES

- Input Power: 110(1.5A)/220VAC(0.8A), 50~60Hz
- Range of selectable DC output voltages: 3, 7, 12, and 14 VDC (PWM)
- Maximum Output Current: 10A
- Control temperature range: -100°C to 200°C
- Control stability: 0.1°C/24h
- Temperature sensor: 2 wire Pt1000 RTD (included)
- Control output: Proportional control with automatic reset and rate (PID), 500 Hz Pulse Width Modulation (PWM)
- Dimensions: 15cm (5.9”) x 12.5cm (4.9”) x 26cm (10.2”)
- 3.5 digit LED display, 4 button user interface
- Extra terminals for constant 12VDC fan operation (up to 1 Ampere)

Available ranges for settings			
Item	Display	Range	Units
Setpoint	88.8 <sup>1</sup>	-100.0 <sup>2</sup> – 199.9	°C
Proportional band	P000 <sup>1</sup>	0 – 20	%
Integral (reset time)	A000 <sup>1</sup>	0 – 250	Seconds
Derivative (rate time)	D000 <sup>1</sup>	0 – 100	Seconds
Calibration offset	C00.0 <sup>1</sup>	-5.0 – 5.0	°C

<sup>1</sup> Number shown only as an example of the display.

<sup>2</sup> -100.0°C will show as “-00.0” in the display.

### global solutions: local support.™

Americas: +1.888.246.9050

Europe: +46.31.704.67.57

Asia: +86.755.2714.1166

CLV-customerservice@lairdtech.com

[www.lairdtech.com/thermal](http://www.lairdtech.com/thermal)

# MTTC-1410

Temperature Controller

## USER MANUAL

### PRODUCT HANDLING

**Do not operate this unit before reading this manual.**

The MTTC-1410 was designed, built, and packaged to withstand the shock and vibration normally associated with shipment by common carriers. Occasionally, improper handling during shipment, such as excessive vibration, crushing, etc., will cause damage to the product. Therefore, a thorough inspection should be provided upon receipt of all shipments. Any packaging tears, dents, scratches, or loose objects are signs of damage and should be noted on the Freight Bill. Packages should be opened promptly and units inspected for concealed damage. If damage is found, an immediate claim must be filed with the freight carrier and an inspection requested. Retain all packing materials. Laird Technologies cannot be responsible for the Consignee's failure to file a timely freight claim.

### WARNING

#### Electrical Shock Hazard

- A. ENSURE THAT THERE IS A CIRCUIT BREAKER ON THE LINE AND THAT IT COMPLIES WITH UNIT'S ELECTRICAL REQUIREMENTS.
- B. PLUG UNIT INTO GROUNDED ELECTRICAL OUTLET ONLY.
- C. IF THE ELECTRICAL SUPPLY CORD IS DAMAGED, IT MUST BE REPLACED BY A CORD WITH AN EQUAL OR HIGHER RATING.
- D. UNPLUG THE POWER CORD BEFORE TURNING THE REAR PANEL VOLTAGE ADJUSTMENT KNOB OR CHANGING THE FUSE.

Failure to follow the above precautions could result in electrical shock, fire, personal injury, or damage to the unit, and will void the warranty.

### GETTING STARTED

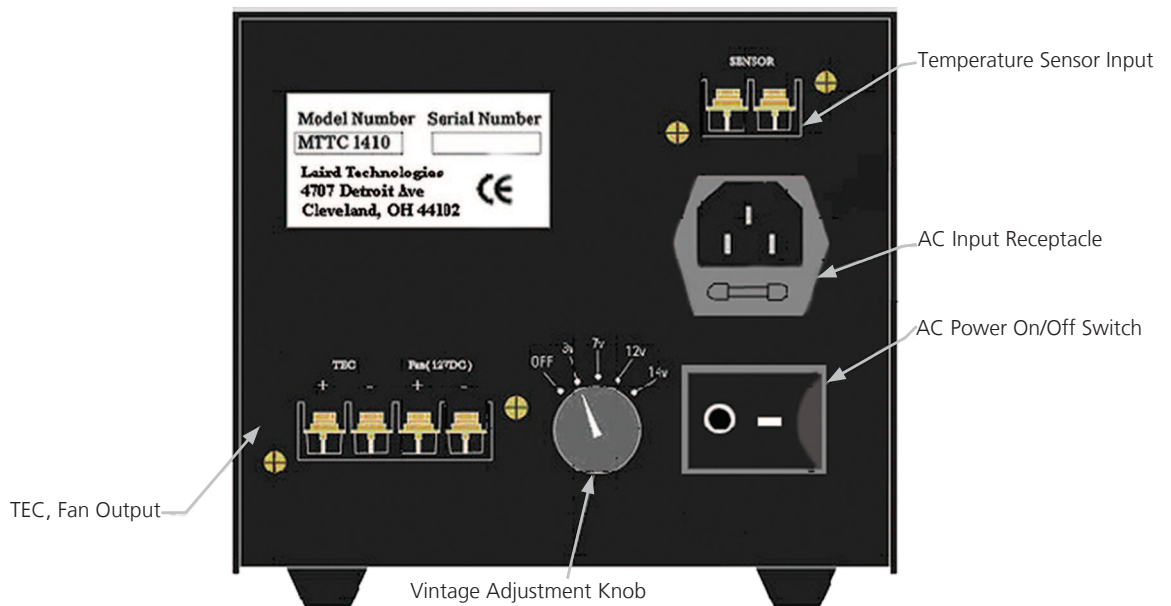

**Figure 1 - Rear Panel**

1. Connect a Pt1000 RTD temperature sensor (provided) to the screw terminals in upper right corner of rear panel (see Fig.1).
2. Plug the AC power cord into the input receptacle at the left of the rear panel.
3. Turn power switch to "ON".

## MTTC-1410

Temperature Controller

### USER MANUAL

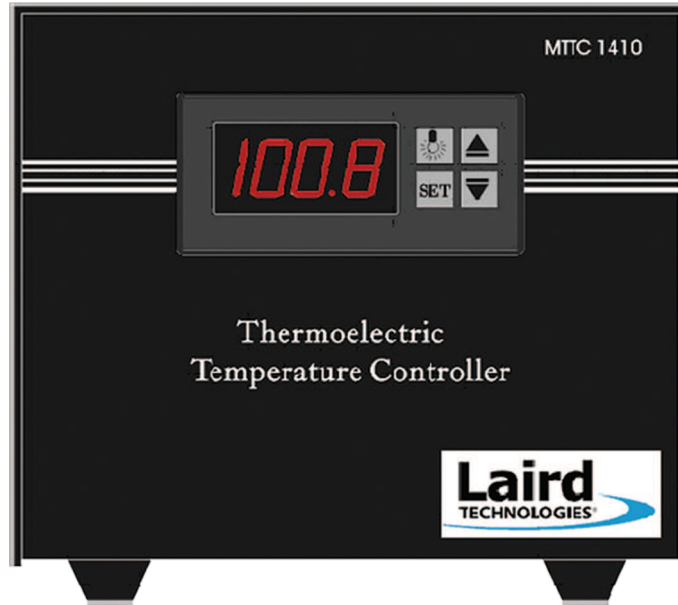

Figure 2 - Front Panel

4. At the user interface in the front (Figures 2 & 3), adjust the setpoint and, if desired, the tuning parameters or calibration offset (see the Controller Adjustment section on the next pages for specific instructions).
5. Back at the rear panel, turn the AC power switch to "OFF", and disconnect the power cord plug from the receptacle
6. Connect your Thermoelectric Cooler (TEC) to the screw terminals located in the lower left corner. Polarity is critical here; if you are not certain of the TEC's polarity, please contact Laird Technologies.
7. If you have a 12VDC fan, connect it to the screw terminals for the fan.
8. Using the voltage adjustment knob, select the peak pulse voltage. In almost all cases, this voltage should be less than or equal to the "Vmax" rating of the TEC. There are other technical considerations based on heat sinking and temperature that may affect your choice of voltage. If you are not certain of what voltage to choose, please contact Laird Technologies.
9. Re connect the power cord, and turn the AC switch to "ON".

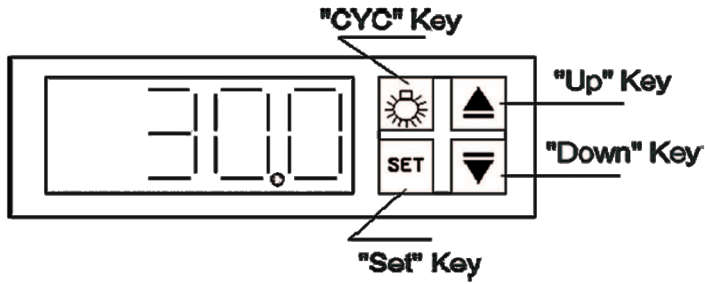

Figure 3 - User Interface

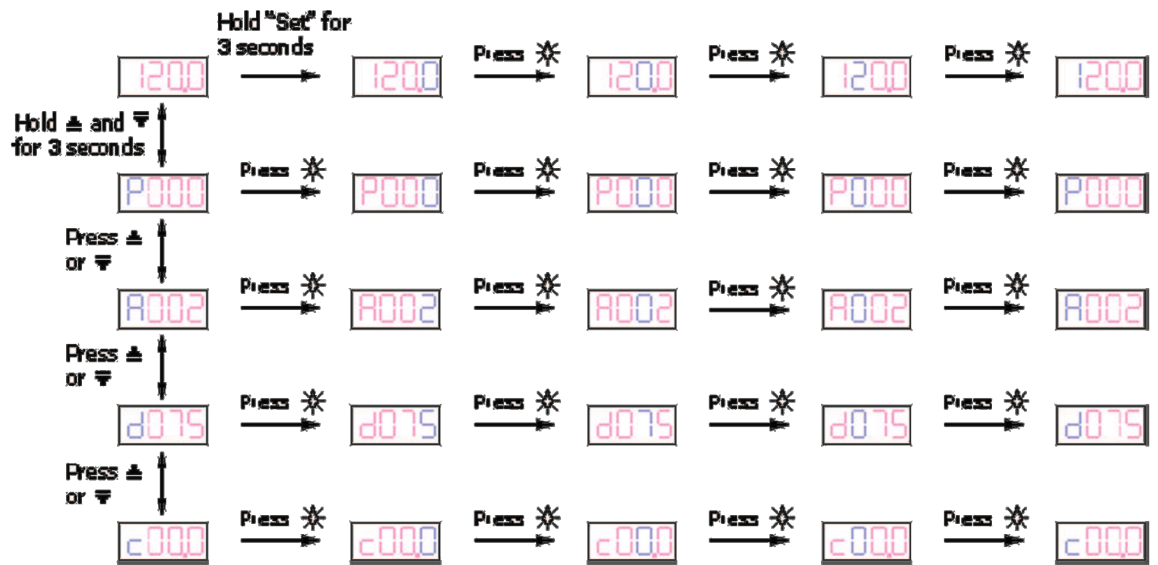

Figure 4 - Functions Menu

In Figure 4, red represents solidly lit digits, while blue represents a blinking digit. The value of a blinking digit can be changed by pressing the "Up" or "Down" keys. Pressing the cycle key ("CYC") changes the position of the blinking digit one step to the left.

- Selecting the setpoint temperature.

Press and hold the "Set" button for 3 seconds. The setpoint temperature will be displayed. Use the "CYC" key to select a digit, and then push either the "Up" or the "Down" key to change the value of the blinking digit. After choosing the set point, press "Set" once more to enter the setpoint temperature. (The "Set" button must be pressed to store the new setpoint; otherwise, the controller will revert to the previous setpoint.)

- Changing PID terms and the calibration offset value.

Press and hold both the "Up" and "Down" buttons for 3 seconds. The Proportional band adjustment will be displayed. Use the "Up" or "Down" keys to scroll through the selection list to select which item is to be adjusted (Proportional band, Integral Time, Derivative Action, Calibration Offset). Press "CYC" to select the digit to be changed, and then push "Up" or "Down" key to change the value of blinking digit. Press "Set" once more to enter the new values. (The "Set" button must be pressed to store the new values; otherwise, the controller will revert to the previous values.)

# MTTC-1410

Temperature Controller

## USER MANUAL

### SERVICEABILITY

No special maintenance is required when using the MTTC-1410. Do not attempt to open the unit. There are no user serviceable internal parts. Opening the unit will void the warranty and could result in injury.

All returns must be assigned a Return Materials Authorization number (RMA#) in advance. Returns received without an RMA# may be refused. In the event that a return is required, the Customer should call Laird Technologies' Customer Service Department at 216-939-2300. The Customer will be asked to fill out an RMA form so that an RMA# can be issued. All returns must be securely packed to prevent shipping damage and must be clearly marked with the RMA# on the box. Consignor shall pay freight charges on all returns.

### WARRANTY

Laird Technologies' MTTC controller adheres to the highest quality standards and is free from defects in material, components, and workmanship. This warranty covers repair or replacement of product, performed by Laird Technologies or by a Laird Technologies authorized agent only, for a period of one (1) year from date of shipment. Customer is responsible for shipping product to Laird Technologies freight prepaid. Laird Technologies in turn will return the warranted product to customer freight prepaid, if within the period specified above. Warranty coverage is in effect when the following operating conditions are continuously satisfied:

- Operating Temperature Range is kept within 18°C (60°F) to 40°C (104°F).
- Line Voltage variation is kept within plus or minus 10% of nameplate rating.
- Applied loads cannot be such that 10 Amperes is ever exceeded on the TEC terminals, or that 1 Ampere is ever exceeded on the 12VDC fan terminals.

In addition, the following criteria must be met:

- Electrical installation and grounding must comply with local electrical and safety codes.
- Recirculating Chiller must be used in the environment for which it is designed.
- Customer cannot abuse or mishandle the product in any way. Any modifications to the original unit will also void warranty.
- Compliance to User's Manual or any other instructional guide provided by Laird Technologies for the product.

This warranty does not cover the following:

- Applications where product is being misapplied. This includes inappropriate selection of Temperature Controller for the environment and conditions in which it is to be used.
- Damages caused by shipping carrier or any other accident after product has left Laird Technologies. Shipping claims are the responsibility of the customer and are to be completed in a timely manner.
- Reimbursement of labor for installation or removal of warranted product, or for parts and labor resulting from repairs performed by any other source besides Laird Technologies.

This is the complete warranty and is in lieu of any other warranty expressed or implied, including but not limited to any implied warranty of merchantability or fitness for a particular purpose. Laird Technologies will in no way be liable for incidental or consequential damage whatsoever or for any other claims by the customer for damages in connection with Laird Technologies products, even if advised in advance of the possibility of such damage.

THR-UM-MTTC-1410 0310

Any information furnished by Laird Technologies, Inc. and its agents is believed to be accurate and reliable. All specifications are subject to change without notice. Responsibility for the use and application of Laird Technologies materials rests with the end user, since Laird Technologies and its agents cannot be aware of all potential uses. Laird Technologies makes no warranties as to the fitness, merchantability or suitability of any Laird Technologies materials or products for any specific or general uses. Laird Technologies shall not be liable for incidental or consequential damages of any kind. All Laird Technologies products are sold pursuant to the Laird Technologies' Terms and Conditions of sale in effect from time to time, a copy of which will be furnished upon request. © Copyright 2010 Laird Technologies, Inc. All Rights Reserved. Laird, Laird Technologies, the Laird Technologies Logo, and other marks are trade marks or registered trade marks of Laird Technologies, Inc. or an affiliate company thereof. Other product or service names may be the property of third parties. Nothing herein provides a license under any Laird Technologies or any third party intellectual property rights.