



Chipsmall Limited consists of a professional team with an average of over 10 year of expertise in the distribution of electronic components. Based in Hongkong, we have already established firm and mutual-benefit business relationships with customers from,Europe,America and south Asia,supplying obsolete and hard-to-find components to meet their specific needs.

With the principle of “Quality Parts,Customers Priority,Honest Operation,and Considerate Service”,our business mainly focus on the distribution of electronic components. Line cards we deal with include Microchip,ALPS,ROHM,Xilinx,Pulse,ON,Everlight and Freescale. Main products comprise IC,Modules,Potentiometer,IC Socket,Relay,Connector.Our parts cover such applications as commercial,industrial, and automotives areas.

We are looking forward to setting up business relationship with you and hope to provide you with the best service and solution. Let us make a better world for our industry!



## Contact us

Tel: +86-755-8981 8866 Fax: +86-755-8427 6832

Email & Skype: info@chipsmall.com Web: www.chipsmall.com

Address: A1208, Overseas Decoration Building, #122 Zhenhua RD., Futian, Shenzhen, China



## ATC 520L Broadband Multilayer Capacitors

### Features:

- EIA 0402 Case Size
- Operating Frequency  
160 KHz to 16 GHz
- Insertion Loss: 1 dB max.
- Low Loss X7R Dielectric
- Solderable SMT Terminations

ATC, the industry leader, is introducing the new 520L Series Multilayer Broadband Capacitor. This device provides low insertion loss performance over multiple octaves of frequency spectrum. The 520L capacitor is compatible with high speed automated pick and place SMT manufacturing.

The 520L is ideal for broadband DC blocking, coupling, bypassing, and feedback applications in optical communications systems and equipment using high-speed digital logic.



### Advantages:

- Broadband Performance
- Low Insertion Loss
- Flat Frequency Response
- Excellent Return Loss through 16 GHz
- Unit-to-Unit Performance Repeatability
- Rugged Ceramic Construction

### 520L Insertion Loss (S21)

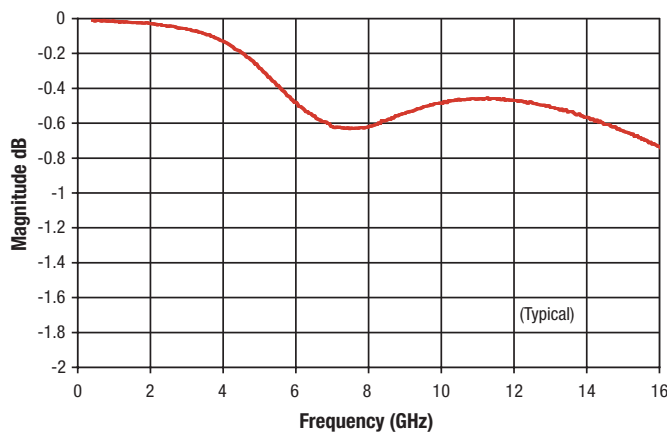

### 520L Return Loss (S11)

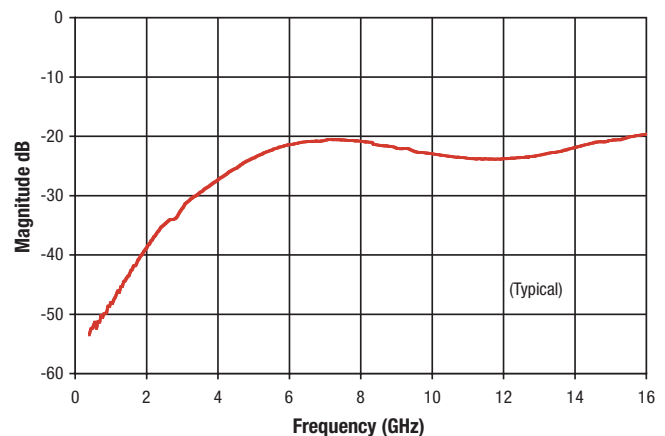

### ATC 520L Data Sheet Test Condition Description

All testing performed on 10-mil-thick Rogers RO4350 microstrip board, with the UUT subtending a 24 mil gap in a 22-mil-wide center trace (nominal 50-ohm characteristic impedance). Measurements were made using an Anritsu 3680K Universal Test Fixture and an HP8722D Vector Network Analyzer having a four-receiver architecture. Measurements have been de-embedded to the edges of the UUT using a standard TRL calibration procedure.



**AMERICAN**  
ATC North America  
sales@atceramics.com

**TECHNICAL**  
ATC Europe  
sales@atceramics.com

**CERAMICS**  
ATC Asia  
sales@atceramics-asia.com

**THE ENGINEERS' CHOICE®**  
ISO 9001 REGISTERED COMPANY

**THE ENGINEERS' CHOICE™**

**www.atceramics.com**

# ATC 520L BROADBAND MULTILAYER CAPACITORS

## Electrical Specifications:

- Capacitance: 10 nF
- Rated Voltage: 16 WVDC
- Dielectric Withstanding Voltage (DWV):  
250% of rated WVDC for 5 secs.
- Operating Temperature Range: -55°C to +125°C
- Temperature Coefficient of Capacitance (TCC):  
±15% (-55°C to +125°C)
- Maximum DF: 3% @ 1KHz
- Insulation Resistance:  
10<sup>11</sup> Ω min. @ +25°C @ rated WVDC  
10<sup>10</sup> Ω min. @ +125°C @ rated WVDC

## Life Test:

- MIL-STD-202, Method 108, for 2000 hours, @ 125 °C with 200% WVDC applied

## Mechanical Dimensions

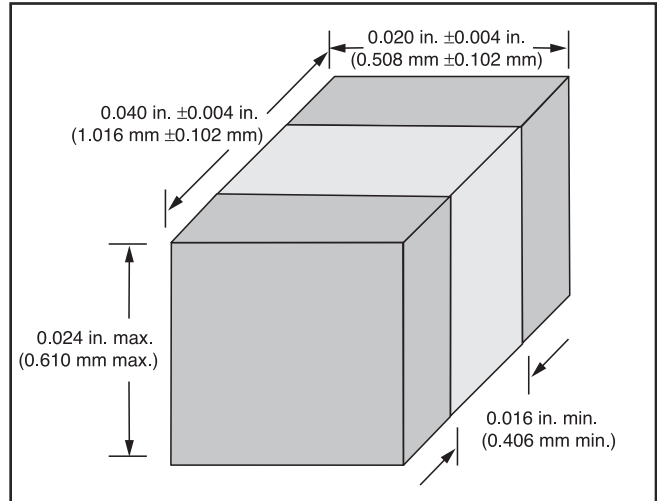

## ATC 520 Series Part Number Code

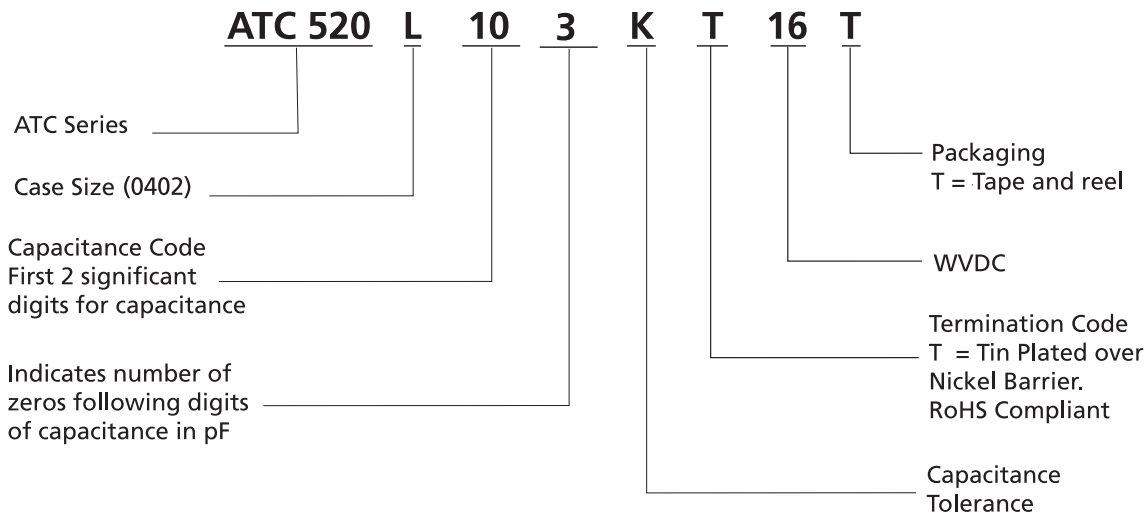

The above part number refers to a 520 Series (case size L) 10 nF capacitor, K tolerance (±10%), with T termination (tin plated over nickel barrier, RoHS compliant), 16 WVDC, tape and reel packaging.

ATC accepts orders for our parts using designations **with** or **without** the "ATC" prefix. Both methods of defining the part number are equivalent, i.e., part numbers referenced with the "ATC" prefix are interchangeable to parts referenced without the "ATC" prefix. Customers are free to use either in specifying or procuring parts from American Technical Ceramics.

For additional information and catalogs contact your ATC representative or call direct at (+1-631) 622-4700. Consult factory for additional performance data.

*Sales of ATC products are subject to the terms and conditions contained in American Technical Ceramics Corp. Terms and Conditions of Sale (ATC document #001-992 Rev. B 12/05). Copies of these terms and conditions will be provided upon request. They may also be viewed on ATC's website at [www.atceramics.com/productfinder/default.asp](http://www.atceramics.com/productfinder/default.asp). Click on the link for Terms and Conditions of Sale.*

*ATC has made every effort to have this information as accurate as possible. However, no responsibility is assumed by ATC for its use, nor for any infringements of rights of third parties which may result from its use. ATC reserves the right to revise the content or modify its product line without prior notice.*

© 2003 American Technical Ceramics. All Rights Reserved.

ATC 001-988 Rev. B; 10/06



**AMERICAN**

ATC North America  
sales@atceramics.com

**TECHNICAL**

ATC Europe  
sales@atceramics.com

**CERAMICS**

ATC Asia  
sales@atceramics-asia.com



THE ENGINEERS' CHOICE™

www.atceramics.com