



Chipsmall Limited consists of a professional team with an average of over 10 year of expertise in the distribution of electronic components. Based in Hongkong, we have already established firm and mutual-benefit business relationships with customers from,Europe,America and south Asia,supplying obsolete and hard-to-find components to meet their specific needs.

With the principle of "Quality Parts,Customers Priority,Honest Operation,and Considerate Service",our business mainly focus on the distribution of electronic components. Line cards we deal with include Microchip,ALPS,ROHM,Xilinx,Pulse,ON,Everlight and Freescale. Main products comprise IC,Modules,Potentiometer,IC Socket,Relay,Connector.Our parts cover such applications as commercial,industrial, and automotives areas.

We are looking forward to setting up business relationship with you and hope to provide you with the best service and solution. Let us make a better world for our industry!



Contact us

Tel: +86-755-8981 8866 Fax: +86-755-8427 6832

Email & Skype: info@chipsmall.com Web: www.chipsmall.com

Address: A1208, Overseas Decoration Building, #122 Zhenhua RD., Futian, Shenzhen, China



REVISONS		DATE	OWN	APPRO
AF	50			
G	REL PER 063A-0546-02	09SEP02	JR	ND

1 USE WITH TERMINAL PART NUMBER: 1217608-1.

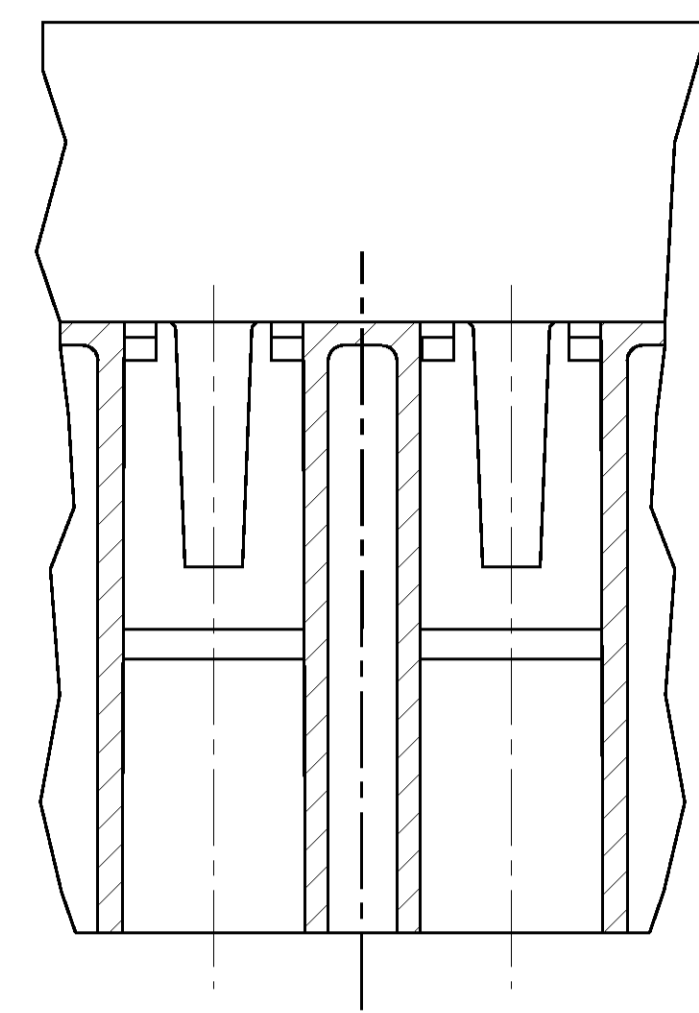

SECTION B-B
WITH ENTIRE REAR VIEW

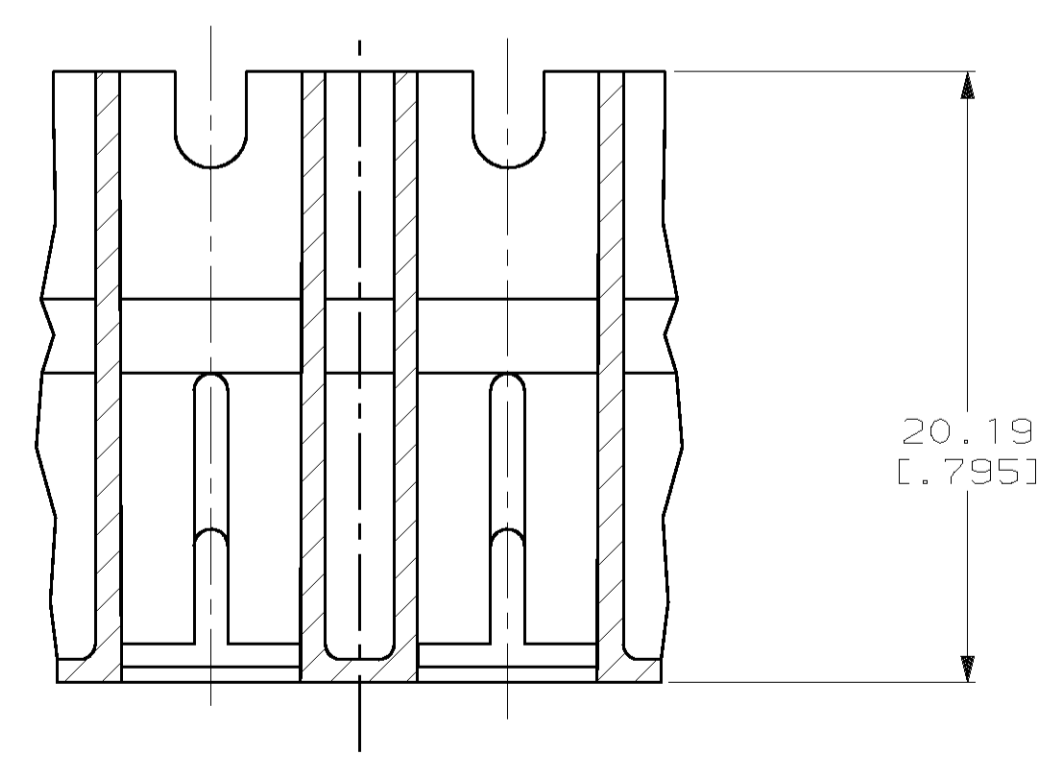
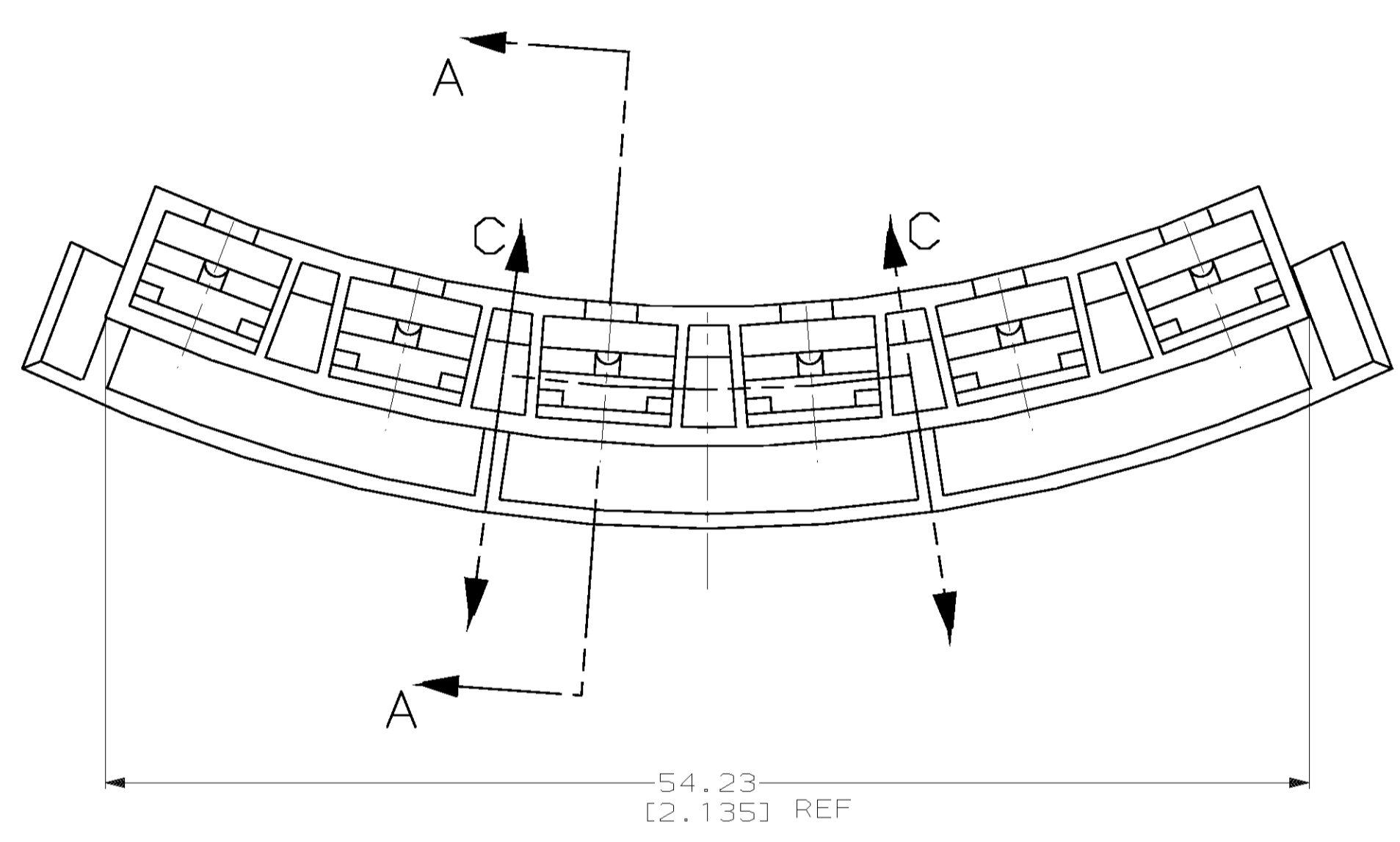

SECTION C-C

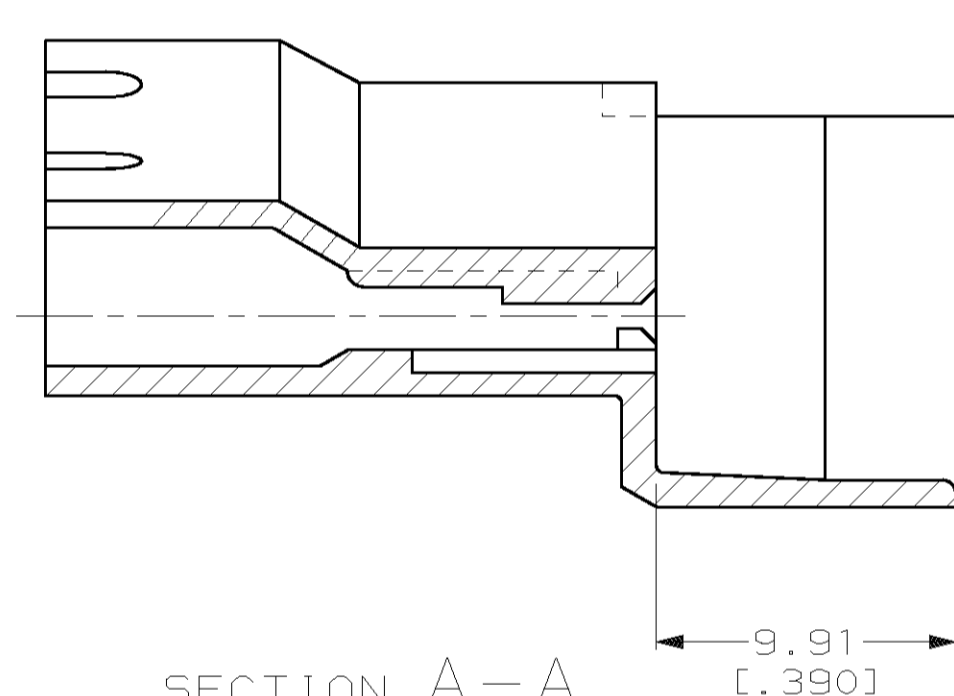

SECTION A-A

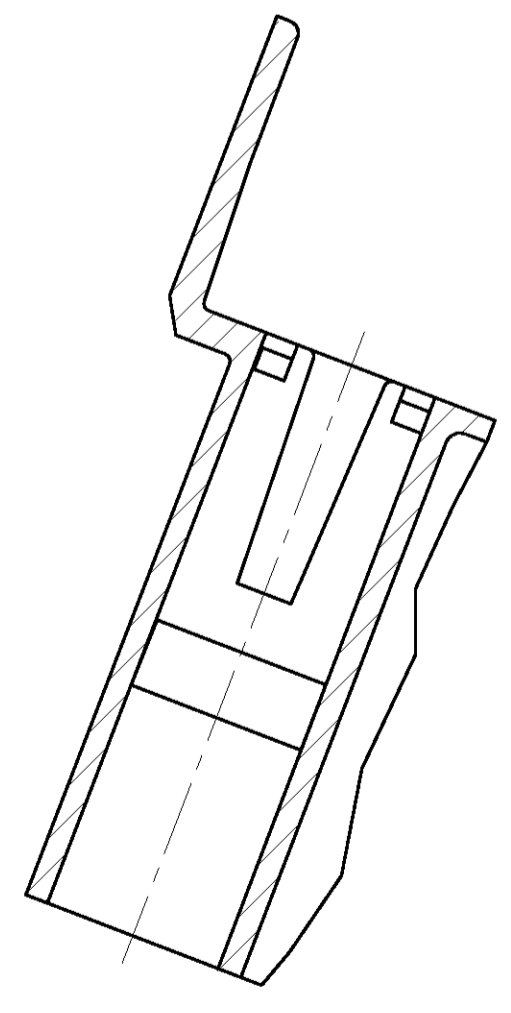
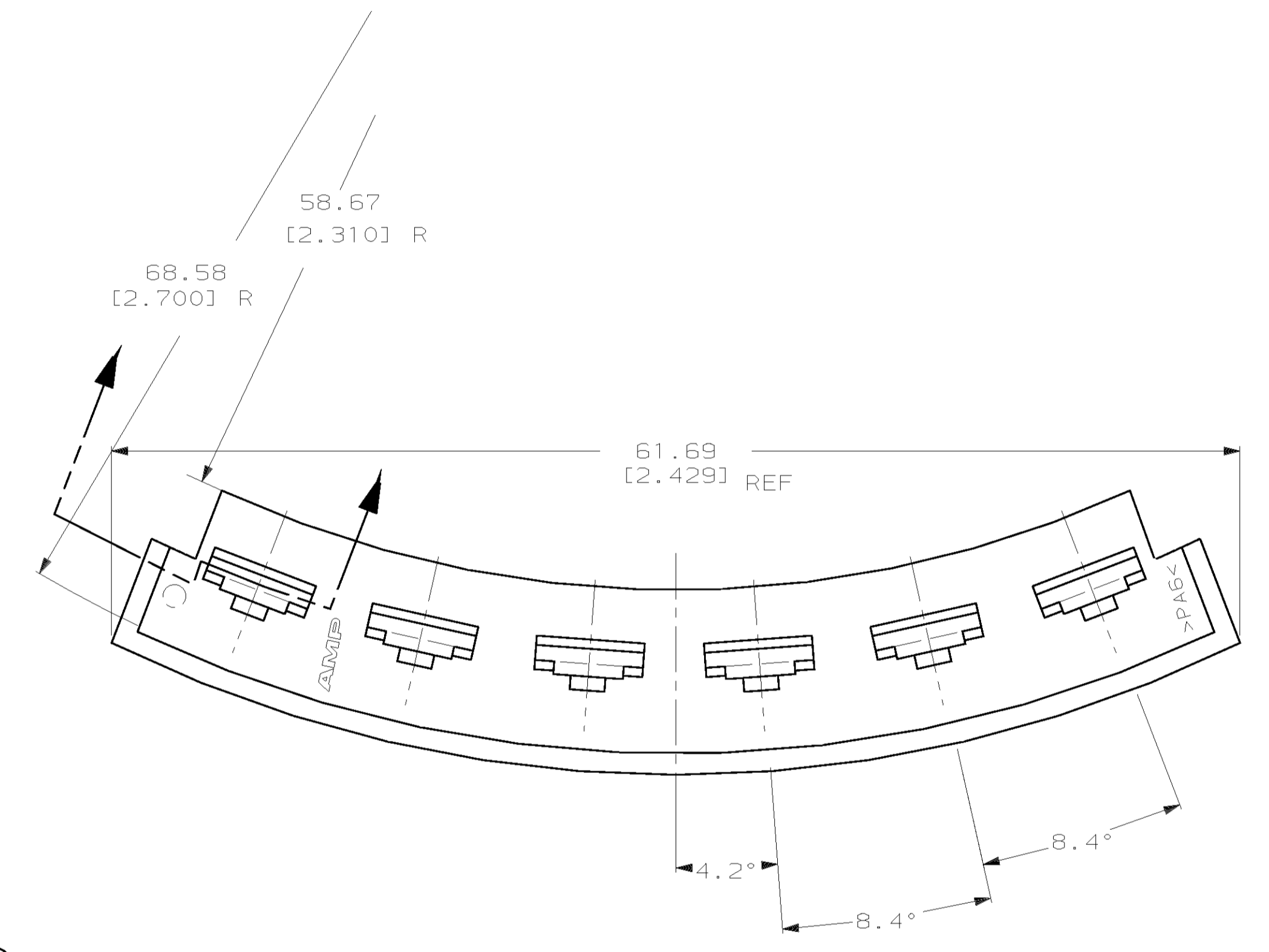

521381-1
PART NUMBER

THIS DRAWING IS A CONTROLLED DOCUMENT.		DWN MICHAEL S. FECHER 13FEB2001	AMP Incorporated Harrisburg, PA 17105-3608
DIMENSIONS: mm [INCHES]		CHK KURT A. RANDOLPH 13FEB2001	
TOLERANCES UNLESS OTHERWISE SPECIFIED:		NAME KURT A. RANDOLPH	HOUSING, RECEPTACLE, FASTIN-FASTON™ 6 POSITION, 4.75 [0.187] SERIES
0 PLC ±-		PRODUCT SPEC	
1 PLC ±-		APPLICATION SPEC	SIZE A1
2 PLC ±0.25 [0.010]		WEIGHT	SCALE CODE DRAWING NO 00779 C-521381
3 PLC ±-		CUSTOMER DRAWING	RESTRICTED TO
4 PLC ±-		SCALE 4:1	SHEET 1 OF 1
ANGLES ±1°		REV G	