



Chipsmall Limited consists of a professional team with an average of over 10 year of expertise in the distribution of electronic components. Based in Hongkong, we have already established firm and mutual-benefit business relationships with customers from,Europe,America and south Asia,supplying obsolete and hard-to-find components to meet their specific needs.

With the principle of “Quality Parts,Customers Priority,Honest Operation,and Considerate Service”,our business mainly focus on the distribution of electronic components. Line cards we deal with include Microchip,ALPS,ROHM,Xilinx,Pulse,ON,Everlight and Freescale. Main products comprise IC,Modules,Potentiometer,IC Socket,Relay,Connector.Our parts cover such applications as commercial,industrial, and automotives areas.

We are looking forward to setting up business relationship with you and hope to provide you with the best service and solution. Let us make a better world for our industry!



Contact us

Tel: +86-755-8981 8866 Fax: +86-755-8427 6832

Email & Skype: info@chipsmall.com Web: www.chipsmall.com

Address: A1208, Overseas Decoration Building, #122 Zhenhua RD., Futian, Shenzhen, China



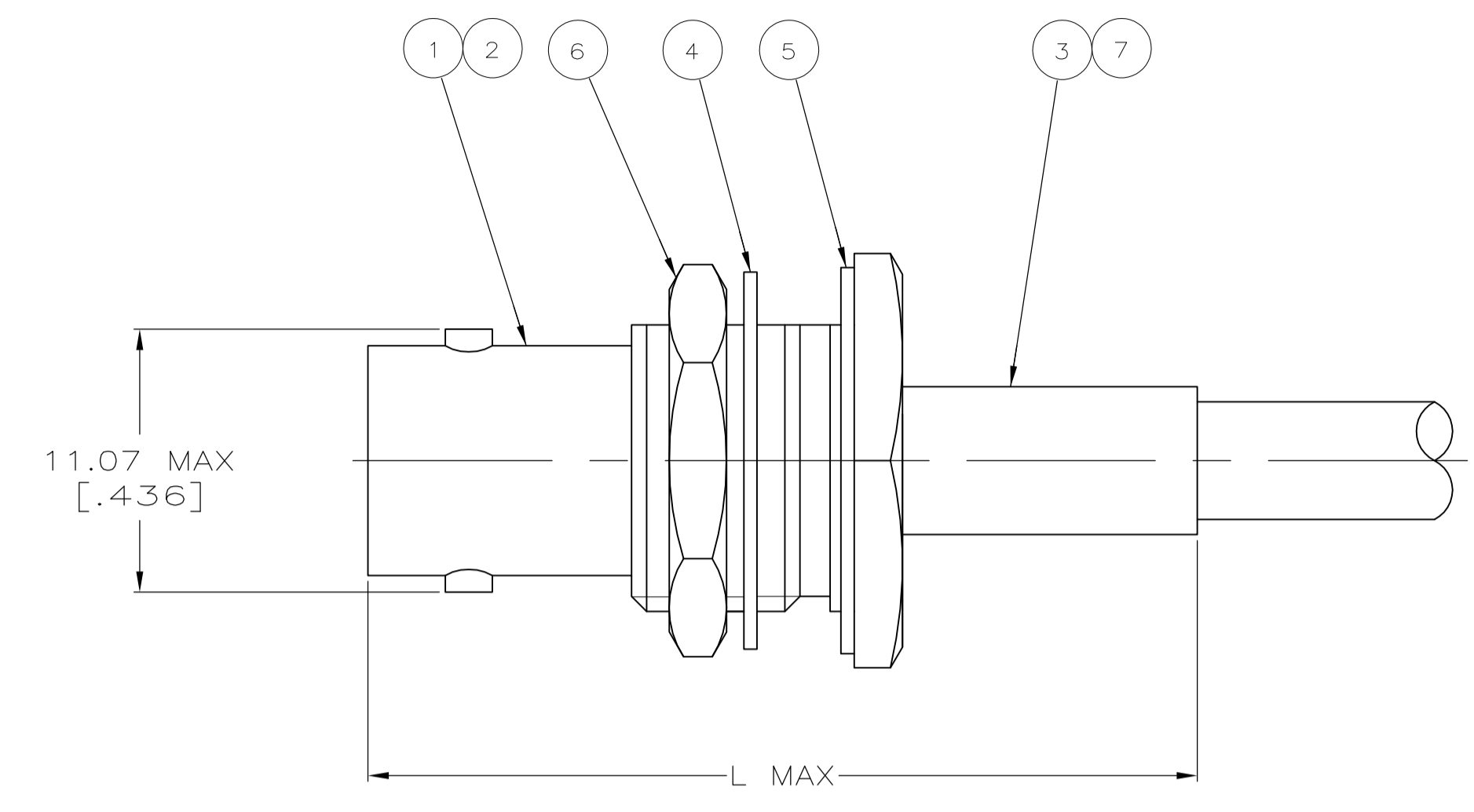

1. MAXIMUM PANEL THICKNESS = 6.10 [.240]
2. USE INSTRUCTION SHEET 408-1914-03

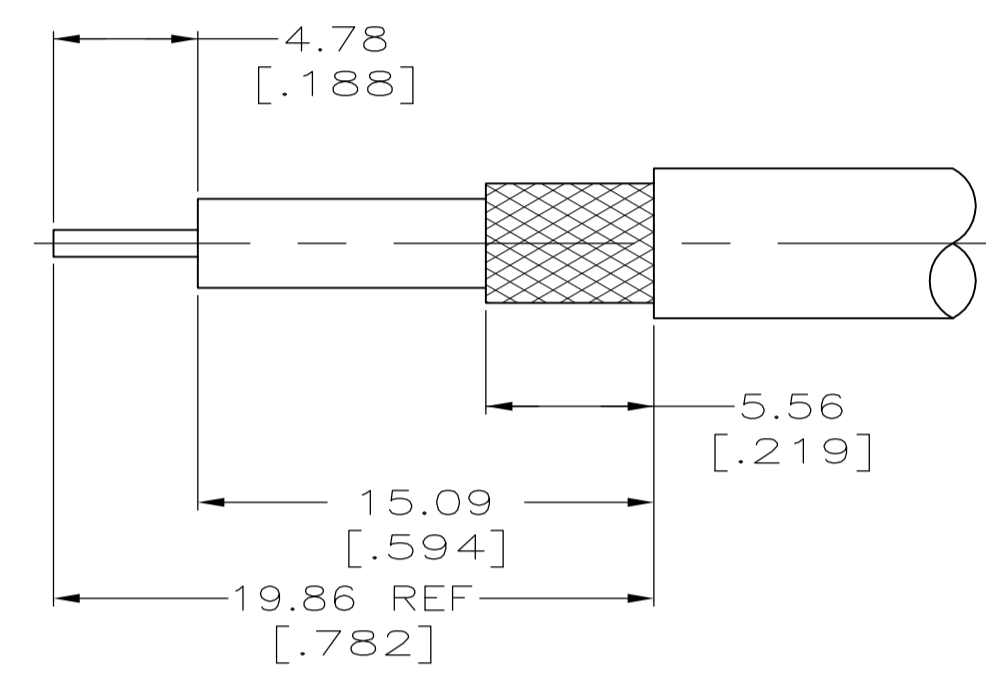

RECOMMENDED PANEL CUTOUT

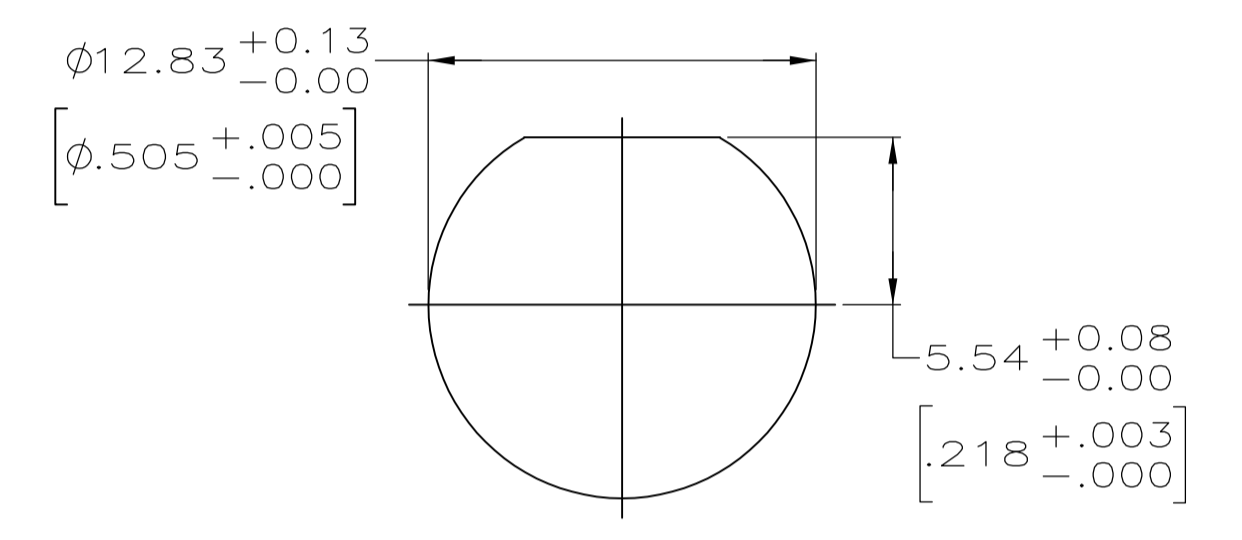

RECOMMENDED PANEL CUTOUT

34.93	[1.375]	RD-316 DOUBLE BRAIDED	-	69477-2	21427-4	1-329631-2	1-329632-2	329633	9-329049-0	1-331368-2	1-331786-6	1-5225398-5
34.93	[1.375]	RG-179/U & 187/U CABLE	.557 OZ	220009-1	21427-4	1-329631-2	1-329632-2	329633	9-328666-0	1-331368-4	1-331786-6	5225398-8
34.93	[1.375]	RG-174/U & 188/U	.582 OZ	220009-1	21427-4	1-329631-2	1-329632-2	329633	9-328666-0	1-331368-2	1-331786-6	5225398-7
38.10	[1.500]	RG-142/U,142A/U & 142B/U	-	220189-3	-	1-329631-2	1-329632-2	329633	9-225382-0	1-331369-7	1-331786-4	5225398-6
38.10	[1.500]	RG55/U,55A/U,55B/U & 223/U	.568 OZ	69478-1	-	1-329631-2	1-329632-2	329633	9-225382-0	1-331369-6	1-331786-4	5225398-3
34.93	[1.375]	RG-58/U,58A/U,58B/U & 58C/U	.582 OZ	69478-1	-	1-329631-2	1-329632-2	329633	9-50427-1	1-331369-6	1-331786-4	5225398-1
L		CABLE	WEIGHT	CRIMP TOOL	⑦ BUSHING QTY=1	⑥ JAM NUT QTY=1	⑤ LOCK WASHER QTY=1	④ GASKET QTY=1	③ FERRULE QTY=1	② CONTACT QTY=1	① JACK ASSEMBLY QTY=1	PART NUMBER

THIS DRAWING IS A CONTROLLED DOCUMENT.

DIMENSIONS: mm [INCHES]	TOLERANCES UNLESS OTHERWISE SPECIFIED:	0 PLC ± -	1 PLC ± -	2 PLC ± 0.41 [016]	3 PLC ± -	4 PLC ± -	ANGLES ± -	MATERIAL -	FINISH -
----------------------------	--	-----------	-----------	--------------------	-----------	-----------	------------	------------	----------

APVD	J. LIPPERT	31JAN2005	NAME
APVD	A. FERNANDEZ-DUCKS	31JAN2005	NAME

STE TE Connectivity

JACK, BULKHEAD, BNC

SIZE: A1 00779 C=5225398

CUSTOMER DRAWING SCALE: 4:1 SHEET: 1 OF 1 REV: P