



Chipsmall Limited consists of a professional team with an average of over 10 year of expertise in the distribution of electronic components. Based in Hongkong, we have already established firm and mutual-benefit business relationships with customers from,Europe,America and south Asia,supplying obsolete and hard-to-find components to meet their specific needs.

With the principle of “Quality Parts,Customers Priority,Honest Operation,and Considerate Service”,our business mainly focus on the distribution of electronic components. Line cards we deal with include Microchip,ALPS,ROHM,Xilinx,Pulse,ON,Everlight and Freescale. Main products comprise IC,Modules,Potentiometer,IC Socket,Relay,Connector.Our parts cover such applications as commercial,industrial, and automotives areas.

We are looking forward to setting up business relationship with you and hope to provide you with the best service and solution. Let us make a better world for our industry!



## Contact us

Tel: +86-755-8981 8866 Fax: +86-755-8427 6832

Email & Skype: info@chipsmall.com Web: www.chipsmall.com

Address: A1208, Overseas Decoration Building, #122 Zhenhua RD., Futian, Shenzhen, China



THIS DRAWING IS UNPUBLISHED. RELEASED FOR PUBLICATION .19  
 © COPYRIGHT 19 BY AMP INCORPORATED. ALL RIGHTS RESERVED.

LOC		DIST		REVISIONS			
P	LTR	DESCRIPTION		DATE	DWN	APVD	
G	86	H	REV PER	063A-0067-99	10AUG99	JR	MS

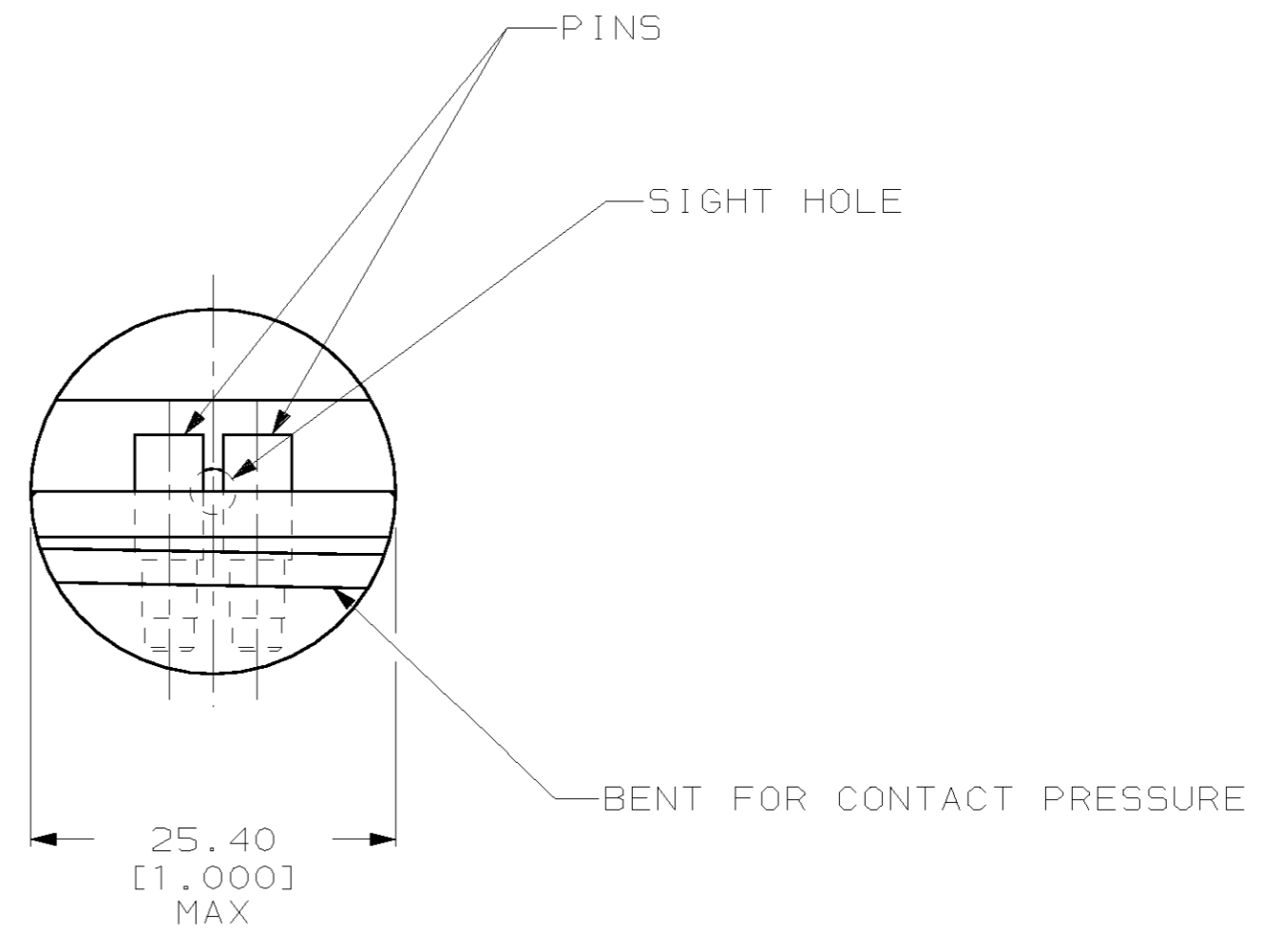
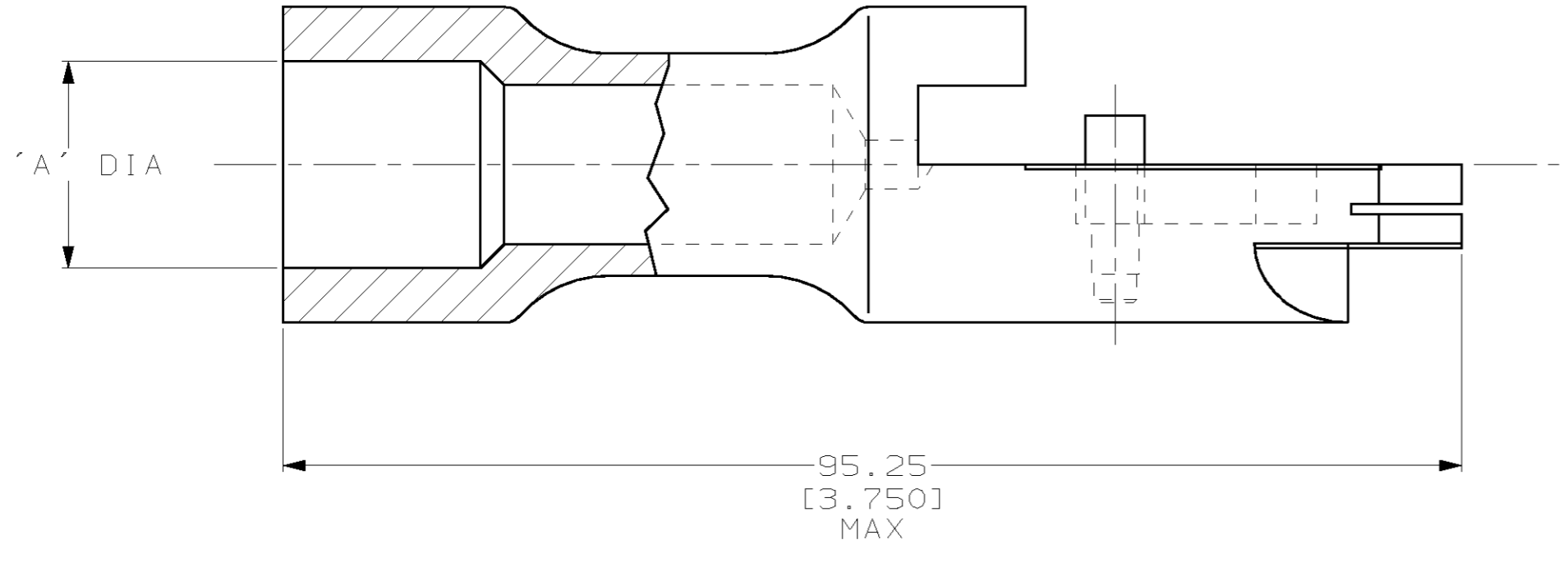
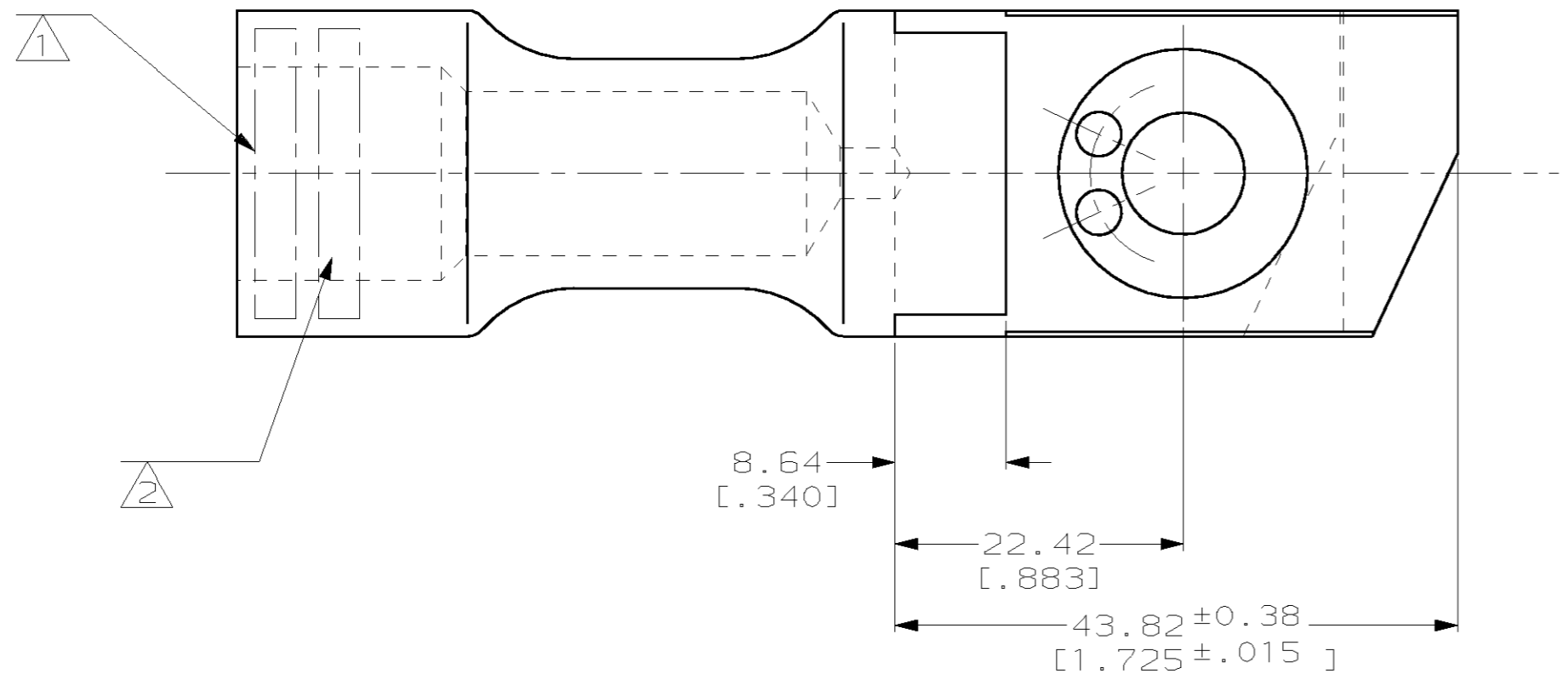

OBsolete	Part No	Wire	Length	Tolerance	Part No
W	7077DB00617	2/0 A33	16.76 [.660]	0.0076 [.0003]	52595-5
W	7077DB0611	2/0 A33	18.24 [.718]	0.0076 [.0003]	52595-4
-	-	AMP 2/0	16.28 [.641]	0.0025 [.0001]	52595-3
-	-	AMP 2/0	17.48 [.688]	0.0025 [.0001]	52595-2
-	-	AMP 2/0	17.91 [.705]	0.0025 [.0001]	52595-1
△	STAMPING	△	'A'	FINISH	AMP PART NUMBER

THIS DRAWING IS A CONTROLLED DOCUMENT FOR AMP INCORPORATED. IT IS SUBJECT TO CHANGE AND THE CONTROLLING ENGINEERING ORGANIZATION SHOULD BE CONTACTED FOR THE LATEST REVISION.		DWN JR RUTH 22JUL99 CHK M SPICER 22JUL99 APVD M SPICER 22JUL99	<b>AMP</b> AMP Incorporated Harrisburg, PA 17105-3608
DIMENSIONS: mm [INCHES]	TOLERANCES UNLESS OTHERWISE SPECIFIED: 0 PLC ±- 1 PLC ±- 2 PLC ±0.20(.008) 3 PLC ±- 4 PLC ±- ANGLES ±-	PRODUCT SPEC 108-13014 APPLICATION SPEC	NAME TERMINAL ASSEMBLY, QUICK-DISCONNECT, AMPPOWER™, WIRE SIZE: 2/0 AWG
MATERIAL BODY & PINS BRASS PER 00-B-626	FINISH SILVER PL MIN THK - SEE TABLE THK PER 00-S-365	WEIGHT - lbs CUSTOMER DRAWING	SIZE A2 CAGE CODE 00779 DRAWING NO C-52595 SCALE 2:1 SHEET 1 OF 1 REV H

52595