



Chipsmall Limited consists of a professional team with an average of over 10 year of expertise in the distribution of electronic components. Based in Hongkong, we have already established firm and mutual-benefit business relationships with customers from,Europe,America and south Asia,supplying obsolete and hard-to-find components to meet their specific needs.

With the principle of “Quality Parts,Customers Priority,Honest Operation,and Considerate Service”,our business mainly focus on the distribution of electronic components. Line cards we deal with include Microchip,ALPS,ROHM,Xilinx,Pulse,ON,Everlight and Freescale. Main products comprise IC,Modules,Potentiometer,IC Socket,Relay,Connector.Our parts cover such applications as commercial,industrial, and automotives areas.

We are looking forward to setting up business relationship with you and hope to provide you with the best service and solution. Let us make a better world for our industry!



Contact us

Tel: +86-755-8981 8866 Fax: +86-755-8427 6832

Email & Skype: info@chipsmall.com Web: www.chipsmall.com

Address: A1208, Overseas Decoration Building, #122 Zhenhua RD., Futian, Shenzhen, China



THIS DRAWING IS UNPUBLISHED. RELEASED FOR PUBLICATION
 © COPYRIGHT BY TYCO ELECTRONICS CORPORATION. ALL INTERNATIONAL RIGHTS RESERVED.

LOC	DIST	REVISIONS			DAP		
P	LTR	DESCRIPTION	DATE	DWN	APVD		
G	14	B	REV PER ECR 09-026308	10DEC09	JR	TM	

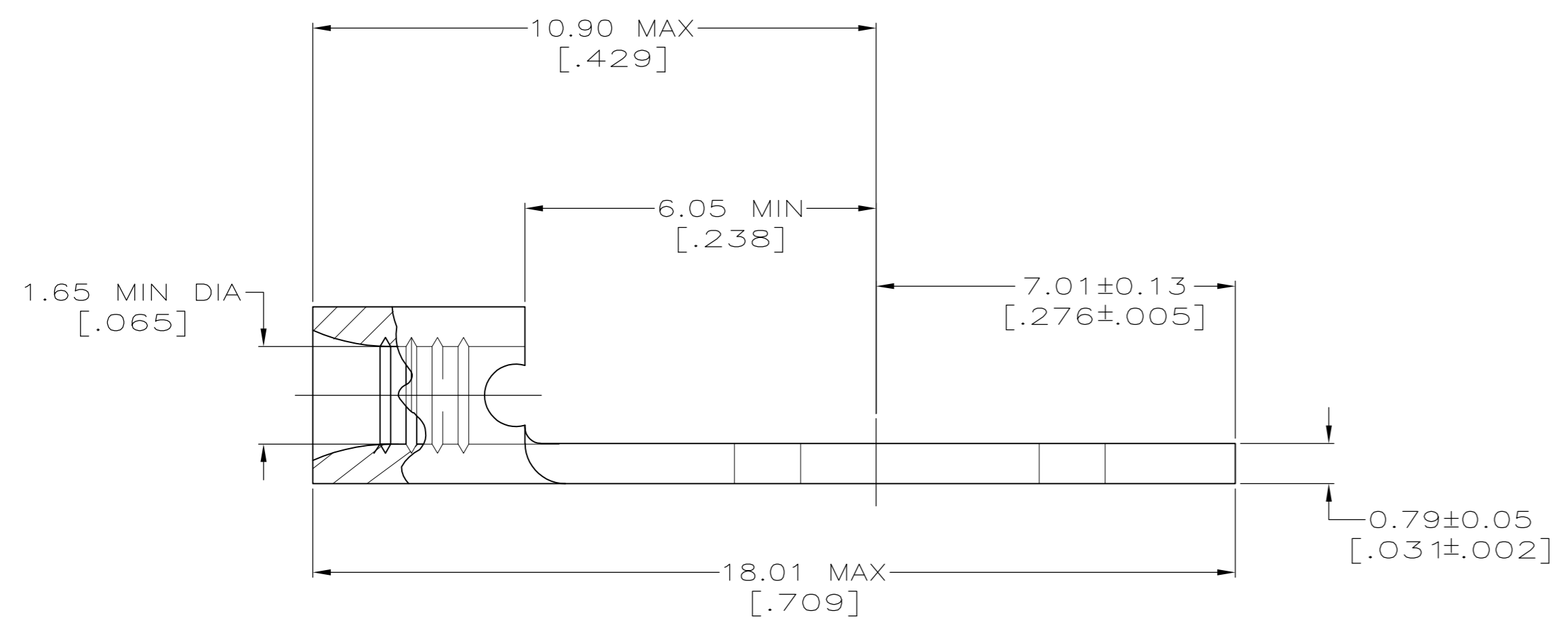
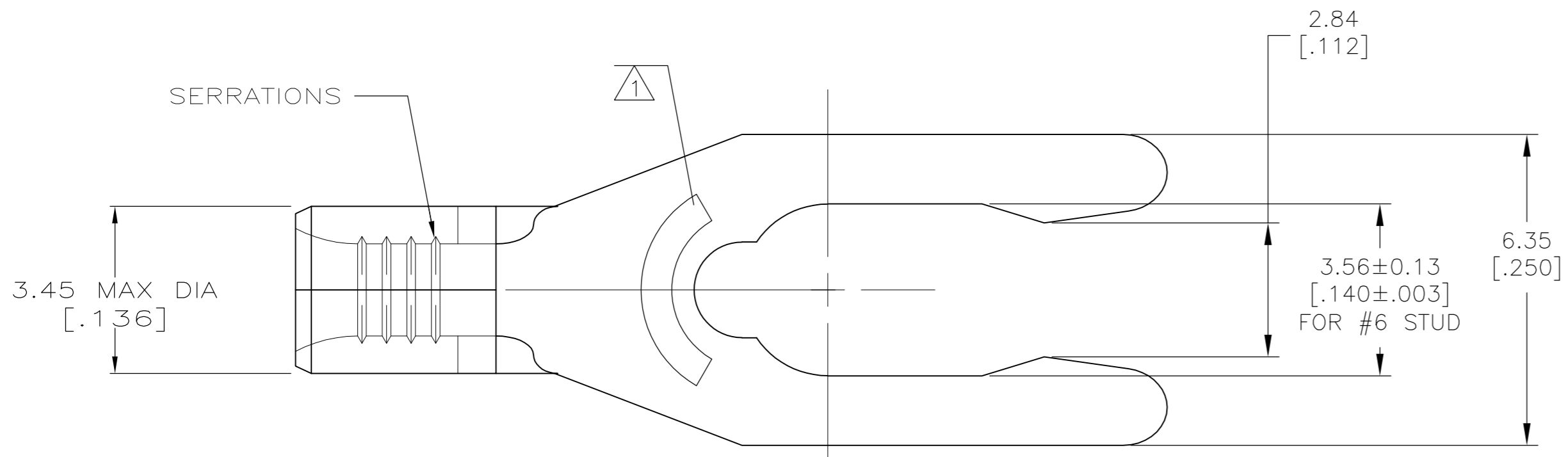

AMP WIRE RANGE	Listed FILE E13288	LR7189 Certified
22-16 AWG STRANDED	22-16 AWG STRANDED	NOT CERTIFIED

- 1 STAMP 8S AMP 22-18* APPROX AS SHOWN
22-16 TERMINALS ARE STAMPED 22-18 IN ACCORDANCE WITH MILITARY SPECIFICATION MIL-T-7928; COMMERCIAL WIRE RANGE IS 22-16 8S INDICATES STUD SIZE
- 2 PHOSPHOR BRONZE PER ASTM B-103, ANNEALED
- 3 TIN PLATE 0.00254 [.000100] MIN PER ASTM B-545
- 4 MAX RECOMMENDED OPERATING TEMP 170°C
- 5 WIRE CROSS SECTIONAL AREA RANGE:
0.26-1.65mm² [509-3,260] CIR MILS STRANDED

52700-1
PART NO.

THIS DRAWING IS A CONTROLLED DOCUMENT.		DWN TA BRINKMAN 2-15-93	Tyco Electronics Corporation Harrisburg, PA 17105-3608	
DIMENSIONS: MM [INCHES]		CHK DA PATTERSON 2-15-93	NAME JL MECKLEY	
TOLERANCES UNLESS OTHERWISE SPECIFIED:		APVD JL MECKLEY 2-15-93	PRODUCT SPEC - APPLICATION SPEC -	
0 PLC ± - 1 PLC ± - 2 PLC ± 0.20 [.008] 3 PLC ± - 4 PLC ± - ANGLES ± -		WEIGHT -	SIZE A2	CAGE CODE 00779
MATERIAL -	FINISH - 2	CUSTOMER DRAWING	DRAWING NO C=52700	RESTRICTED TO -
SCALE 10:1			SHEET 1 of 1	REV B