



Chipsmall Limited consists of a professional team with an average of over 10 year of expertise in the distribution of electronic components. Based in Hongkong, we have already established firm and mutual-benefit business relationships with customers from,Europe,America and south Asia,supplying obsolete and hard-to-find components to meet their specific needs.

With the principle of “Quality Parts,Customers Priority,Honest Operation,and Considerate Service”,our business mainly focus on the distribution of electronic components. Line cards we deal with include Microchip,ALPS,ROHM,Xilinx,Pulse,ON,Everlight and Freescale. Main products comprise IC,Modules,Potentiometer,IC Socket,Relay,Connector.Our parts cover such applications as commercial,industrial, and automotives areas.

We are looking forward to setting up business relationship with you and hope to provide you with the best service and solution. Let us make a better world for our industry!



Contact us

Tel: +86-755-8981 8866 Fax: +86-755-8427 6832

Email & Skype: info@chipsmall.com Web: www.chipsmall.com

Address: A1208, Overseas Decoration Building, #122 Zhenhua RD., Futian, Shenzhen, China



THIS DRAWING IS UNPUBLISHED. RELEASED FOR PUBLICATION
 © COPYRIGHT BY TYCO ELECTRONICS CORPORATION. ALL INTERNATIONAL RIGHTS RESERVED.

LOC	DIST	REVISIONS			
P	LTR	DESCRIPTION	DATE	DWN	APVD
G	14	D1	REV PER ECR 10-013673	29JUN10	JR TM

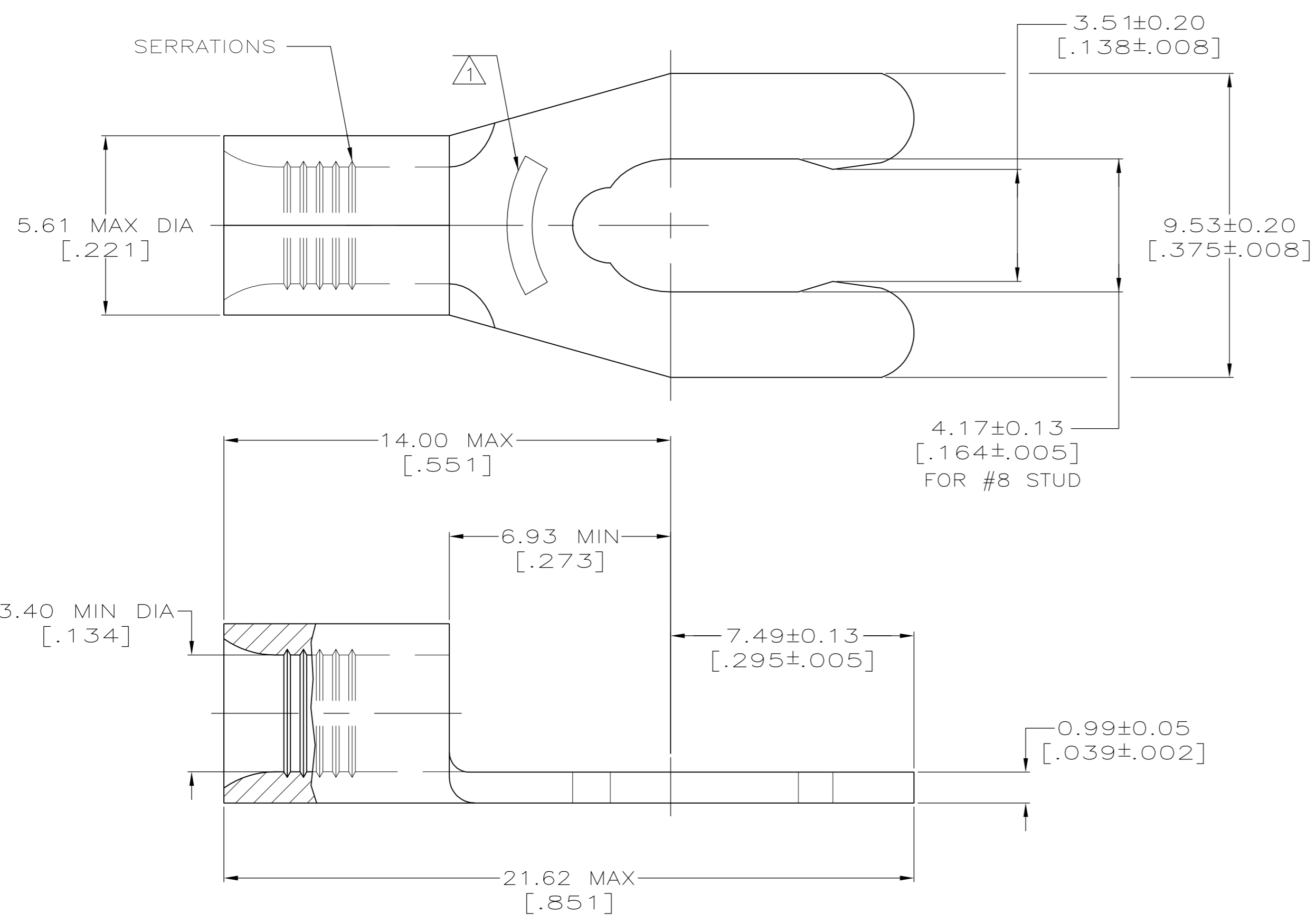

AMP WIRE RANGE	Listed FILE E13288	LR7189 Certified
12-10 AWG STRANDED	12-10 AWG STRANDED	NOT CERTIFIED

- 1 STAMP 8S AMP 12-10* APPROX AS SHOWN
8S INDICATES STUD SIZE
- 2 PHOSPHOR BRONZE PER ASTM B-103, ANNEALED
- 3 TIN PLATE 0.00254 [.000100] MIN PER ASTM B545

OBsolete	2500	ON TAPE	52707-3
	--	LOOSE PIECE	52707-1
	QTY	PACKAGING TYPE	PART NO.

MAX RECOMMENDED OPERATING TEMPERATURE: 170°C MAX	THIS DRAWING IS A CONTROLLED DOCUMENT.		DWN TA BRINKMAN 2-16-93	Tyco Electronics Corporation Harrisburg, PA 17105-3608
	VOLTAGE RATING: N/A	DIMENSIONS: MM [INCHES]	CHK DA PATTERSON 2-16-93	
CIRCULAR MIL AREA: 2.62-6.64mm² [5,180-13,100] STRANDED	TOLERANCES UNLESS OTHERWISE SPECIFIED: 0 PLC ± - 1 PLC ± - 2 PLC ± - 3 PLC ± - 4 PLC ± - ANGLES ± -	MATERIAL -2	FINISH -3	NAME TERMINAL, LONG SPRING SPADE, BUDGET
				SIZE A2
				CAGE CODE 00779
				DRAWING NO 52707
				RESTRICTED TO -
				SCALE 8:1
				SHEET 1 of 1
				REV D1