



Chipsmall Limited consists of a professional team with an average of over 10 year of expertise in the distribution of electronic components. Based in Hongkong, we have already established firm and mutual-benefit business relationships with customers from,Europe,America and south Asia,supplying obsolete and hard-to-find components to meet their specific needs.

With the principle of “Quality Parts,Customers Priority,Honest Operation,and Considerate Service”,our business mainly focus on the distribution of electronic components. Line cards we deal with include Microchip,ALPS,ROHM,Xilinx,Pulse,ON,Everlight and Freescale. Main products comprise IC,Modules,Potentiometer,IC Socket,Relay,Connector.Our parts cover such applications as commercial,industrial, and automotives areas.

We are looking forward to setting up business relationship with you and hope to provide you with the best service and solution. Let us make a better world for our industry!



Contact us

Tel: +86-755-8981 8866 Fax: +86-755-8427 6832

Email & Skype: info@chipsmall.com Web: www.chipsmall.com

Address: A1208, Overseas Decoration Building, #122 Zhenhua RD., Futian, Shenzhen, China



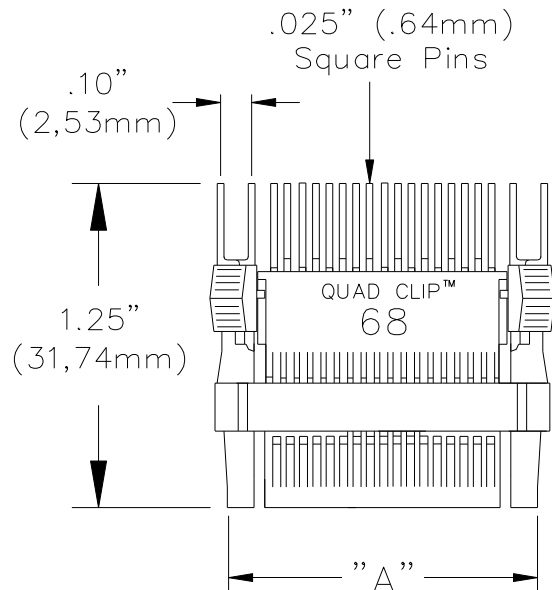
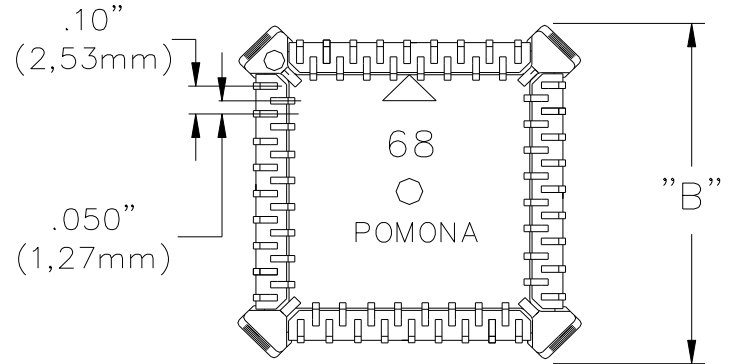
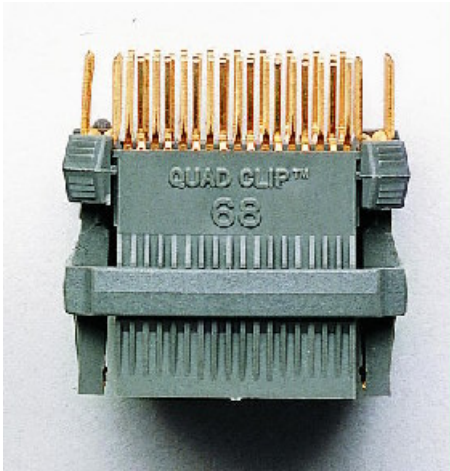

FEATURES:

- ✓ Test adapters are designed for testing surface mounted PLCC chips with "J" leads (JEDEC MO-047 and MO-052).
- ✓ The patented lock-on design attaches directly to the surface mounted
- ✓ IC and provides hands-free access to all of the chip leads.
- ✓ Gold plated upper contacts assure noise free, low resistance connections.
- ✓ Standard .025 square pins accept wire-wrap, .025 sq. receptacle or soldered wires.
- ✓ Pins are staggered to use the least space
- ✓ Gold plated lower contacts assure the best connection to chip leads.

ORDERING INFORMATION: (single PLCC clip)

Model Number	No. of Pins	Pins per Side	Space Required "B"	Board Footprint "A"
5279	20	5x5	.675" (17,14mm)	0.560" (14,23mm)
5280	28	7x7	.775" (19,68mm)	0.665" (16,89mm)
5733	32	7x9	.775" x .875" (19,68mm x 22,22mm)	.665" x .765" (16,89mm x 19,43mm)
5281	44	11x11	.975" (24,77mm)	0.865" (21,97mm)
5312	52	13x13	1.075" (27,31mm)	0.965" (24,51mm)
5401	68	17x17	1.275" (32,39mm)	1.180" (29,97mm)
5402	84	21x21	1.520" (38,60mm)	1.350" (34,29mm)

All dimensions are in inches. Tolerances (except noted): .xx = ±.02" (.51 mm), .xxx = ±.005" (.127 mm).
 All specifications are to the latest revisions. Specifications are subject to change without notice.
 Registered trademarks are the property of their respective companies.

Sales: 800-490-2361 Fax: 888-403-3360 Technical Support: 800-241-2060 (technicalsupport@pomonatest.com)
 For "Where to Buy" information, visit the Pomona web site at www.pomonaelectronics.com

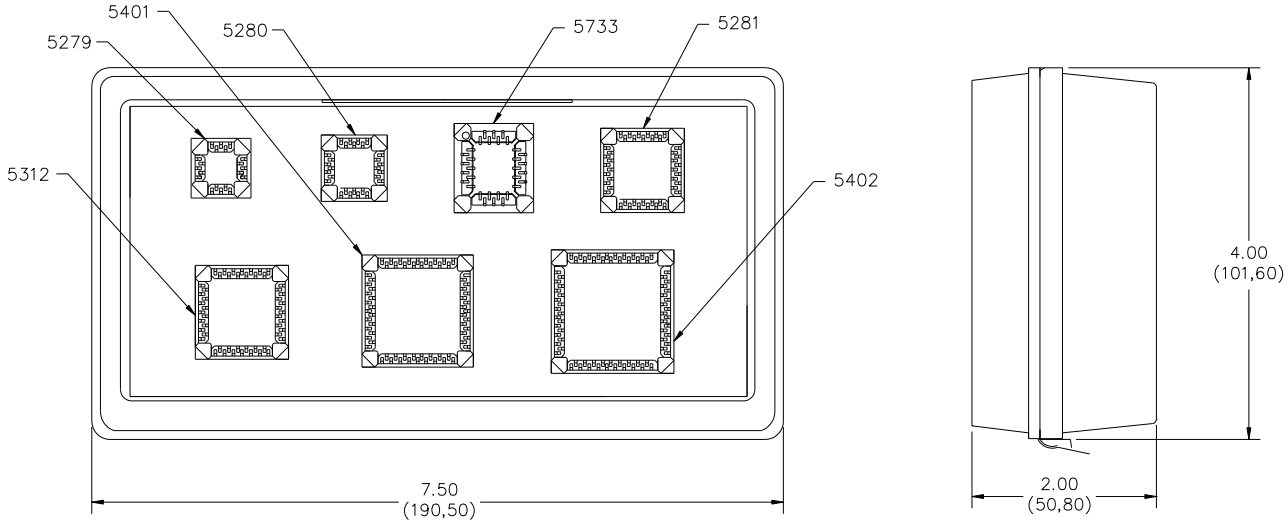

5515A PLCC Test Clip Kit

Kit includes:
1 each of the following PLCC test clips:
5279 (20 pins)
5280 (28 pins)
5733 (32 pins)
5281 (44 pins)
5312 (52 pins)
5401 (68 pins)
5402 (84 pins)

RATINGS:

Operating Voltage: Hands free usage in controlled voltage environments: 500 Vrms maximum. *For CE compliance:* not intended for hand-held use at voltages above 33 Vrms/70 Vdc.

Current: 1 Amperes

Operating Temperature: +215°F (+102°C)

MATERIALS:

Lower Contacts: Gold Plated Beryllium Copper per QQ-C-533, Alloy 172, HM.

Upper Contacts: Gold Plated Phosphor Bronze, Alloy 510, Grade A

Body: Gray, glass-filled nylon

ORDERING INFORMATION: Model 5515A (PLCC kit)

All dimensions are in inches. Tolerances (except noted): .xx = ±.02" (.51 mm), .xxx = ±.005" (.127 mm).

All specifications are to the latest revisions. Specifications are subject to change without notice.

Registered trademarks are the property of their respective companies.

Sales: 800-490-2361 Fax: 888-403-3360 Technical Support: 800-241-2060 (technicalsupport@pomonatest.com)

For "Where to Buy" information, visit the Pomona web site at www.pomonaelectronics.com