



Chipsmall Limited consists of a professional team with an average of over 10 year of expertise in the distribution of electronic components. Based in Hongkong, we have already established firm and mutual-benefit business relationships with customers from,Europe,America and south Asia,supplying obsolete and hard-to-find components to meet their specific needs.

With the principle of “Quality Parts,Customers Priority,Honest Operation,and Considerate Service”,our business mainly focus on the distribution of electronic components. Line cards we deal with include Microchip,ALPS,ROHM,Xilinx,Pulse,ON,Everlight and Freescale. Main products comprise IC,Modules,Potentiometer,IC Socket,Relay,Connector.Our parts cover such applications as commercial,industrial, and automotives areas.

We are looking forward to setting up business relationship with you and hope to provide you with the best service and solution. Let us make a better world for our industry!



Contact us

Tel: +86-755-8981 8866 Fax: +86-755-8427 6832

Email & Skype: info@chipsmall.com Web: www.chipsmall.com

Address: A1208, Overseas Decoration Building, #122 Zhenhua RD., Futian, Shenzhen, China



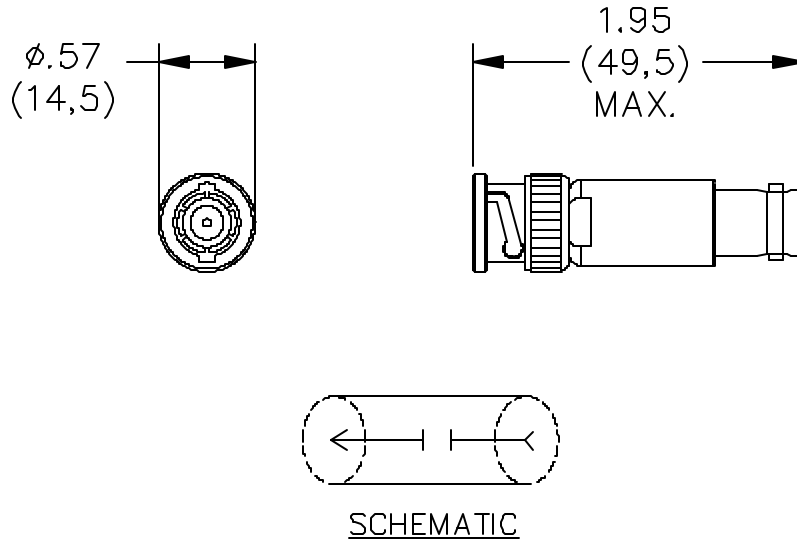

MATERIALS:

Body and Fittings – Gold Plated Brass, Male Contact – Gold Plated Brass, Female Contact – Gold Plated Beryllium Copper

Dielectric: Teflon per L-P-403

Finish: Body and Fittings: Tarnish resistant

Center & Intermediate contacts: Gold Plated

Outer Contact: Tarnish resistant

Marking: “Pomona 5297, 1000 pF”

Specifications: Capacitor – Tubular, 1000pF, $\pm 10\%$, 600 VDC

RATINGS:

Operating Voltage: Shield/Earth: 30VAC/60VDC Max.

Operating Temperature: +102°C. (+216°F.) Max.

Capitance: 1000 pF

Frequency Range: DC to 500 MHz.

ORDERING INFORMATION: Model 5297

All dimensions are in inches and metric. All specifications are to the latest revisions. Specifications are subject to change without notice. Registered trademarks are the property of their respective companies. Made in USA