



Chipsmall Limited consists of a professional team with an average of over 10 year of expertise in the distribution of electronic components. Based in Hongkong, we have already established firm and mutual-benefit business relationships with customers from,Europe,America and south Asia,supplying obsolete and hard-to-find components to meet their specific needs.

With the principle of "Quality Parts,Customers Priority,Honest Operation,and Considerate Service",our business mainly focus on the distribution of electronic components. Line cards we deal with include Microchip,ALPS,ROHM,Xilinx,Pulse,ON,Everlight and Freescale. Main products comprise IC,Modules,Potentiometer,IC Socket,Relay,Connector.Our parts cover such applications as commercial,industrial, and automotives areas.

We are looking forward to setting up business relationship with you and hope to provide you with the best service and solution. Let us make a better world for our industry!



Contact us

Tel: +86-755-8981 8866 Fax: +86-755-8427 6832

Email & Skype: info@chipsmall.com Web: www.chipsmall.com

Address: A1208, Overseas Decoration Building, #122 Zhenhua RD., Futian, Shenzhen, China

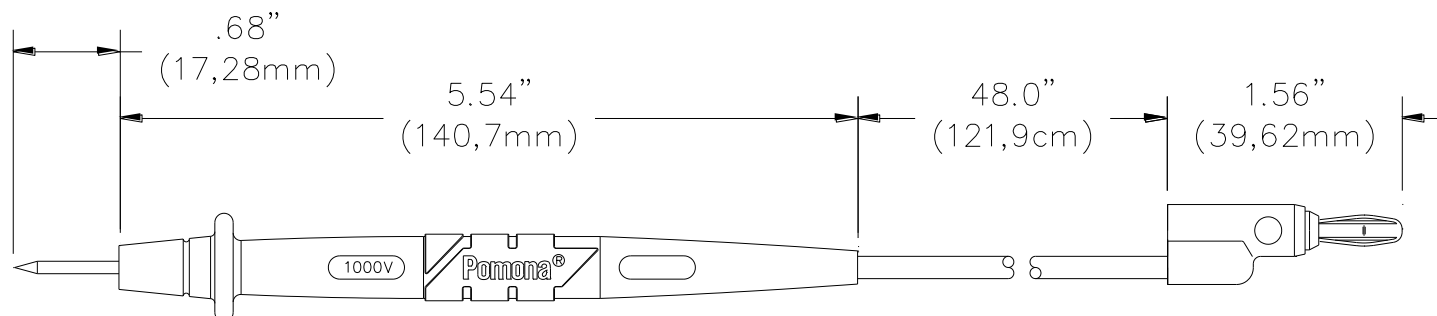

Model 5309A
Replacement DMM Test Lead Set For Industrial Use**FEATURES**

- Designed for DMM's with non-sheathed banana jacks.
- Probe body incorporates a two-step mold process. First step is Polypropylene for probe rigidity. Second step is Santoprene® rubber for handling comfort, added insulation protection and wire strain relief.
- Probe body and banana plug are molded directly to the wire for robust pull strength.
- Wire is a high strand count silicone wire for extreme flexibility and high temperature resistance.
- Wear indication with double insulated (dual extruded) silicone leads shows white inner layer for increased safety.
- The Stainless Steel .080" (2mm) tip is provided for heavy-duty industrial applications.

MATERIALS*Probe Body:*

Outer Insulation – Santoprene® Rubber, Color: Gray

Inner Insulation – Polypropylene, Fire Retardant

Color: One Black, One Red

Tip: Stainless Steel

Wire:

18 AWG, 192 x 41 bare copper, Silicone Insulation, O.D. 0.144" (3,66mm), Length: 48" (121,9cm)

Banana Plug:

Body – Brass, Nickel Plated

Spring – Beryllium Copper, Nickel Plated

Insulation: Polypropylene, Color: One Black, One Red

RATINGS

Voltage: For CE compliance and for personal safety, do not hold in hand when voltages exceed 30 Vrms/42.4 Vpk/60 Vdc or current exceeds 8A maximum. Maximum voltage for hands free use: 1000 V. Do not use on circuits where transient stresses can exceed the rated voltage.

Current: 10 Amps

ORDERING INFORMATION

Model 5309A (set of one Black and one Red test lead)

USA: Sales: 800-490-2361
Technical Support: technicalsupport@pomonatest.com
Fax: 425-446-5844

Europe: 31-(0) 40 2675 150 **International:** 425-446-5500

Where to Buy: www.pomonaelectronics.com

All dimensions are in inches. Tolerances (except noted): .xx = ±.02" (.51 mm), .xxx = ±.005" (.127 mm). All specifications are to the latest revisions. Specifications are subject to change without notice. Registered trademarks are the property of their respective companies.