



Chipsmall Limited consists of a professional team with an average of over 10 year of expertise in the distribution of electronic components. Based in Hongkong, we have already established firm and mutual-benefit business relationships with customers from,Europe,America and south Asia,supplying obsolete and hard-to-find components to meet their specific needs.

With the principle of “Quality Parts,Customers Priority,Honest Operation,and Considerate Service”,our business mainly focus on the distribution of electronic components. Line cards we deal with include Microchip,ALPS,ROHM,Xilinx,Pulse,ON,Everlight and Freescale. Main products comprise IC,Modules,Potentiometer,IC Socket,Relay,Connector.Our parts cover such applications as commercial,industrial, and automotives areas.

We are looking forward to setting up business relationship with you and hope to provide you with the best service and solution. Let us make a better world for our industry!



## Contact us

Tel: +86-755-8981 8866 Fax: +86-755-8427 6832

Email & Skype: info@chipsmall.com Web: www.chipsmall.com

Address: A1208, Overseas Decoration Building, #122 Zhenhua RD., Futian, Shenzhen, China



THIS DRAWING IS UNPUBLISHED. RELEASED FOR PUBLICATION  
 © COPYRIGHT BY TYCO ELECTRONICS CORPORATION. ALL RIGHTS RESERVED.

| LOC | DIST | REVISIONS |     |                       |         |     |      |
|-----|------|-----------|-----|-----------------------|---------|-----|------|
| G   | 14   | P         | LTR | DESCRIPTION           | DATE    | DWN | APVD |
|     |      | L         |     | REV PER ECR 10-005023 | 05MAR10 | JR  | TM   |

|                                |                                |                                |
|--------------------------------|--------------------------------|--------------------------------|
| <b>AMP</b><br>WIRE RANGE       | Listed<br>FILE E13288          | LR7189<br>Certified            |
| 16-14 AWG<br>SOLID OR STRANDED | 16-14 AWG<br>SOLID OR STRANDED | 16-14 AWG<br>SOLID OR STRANDED |

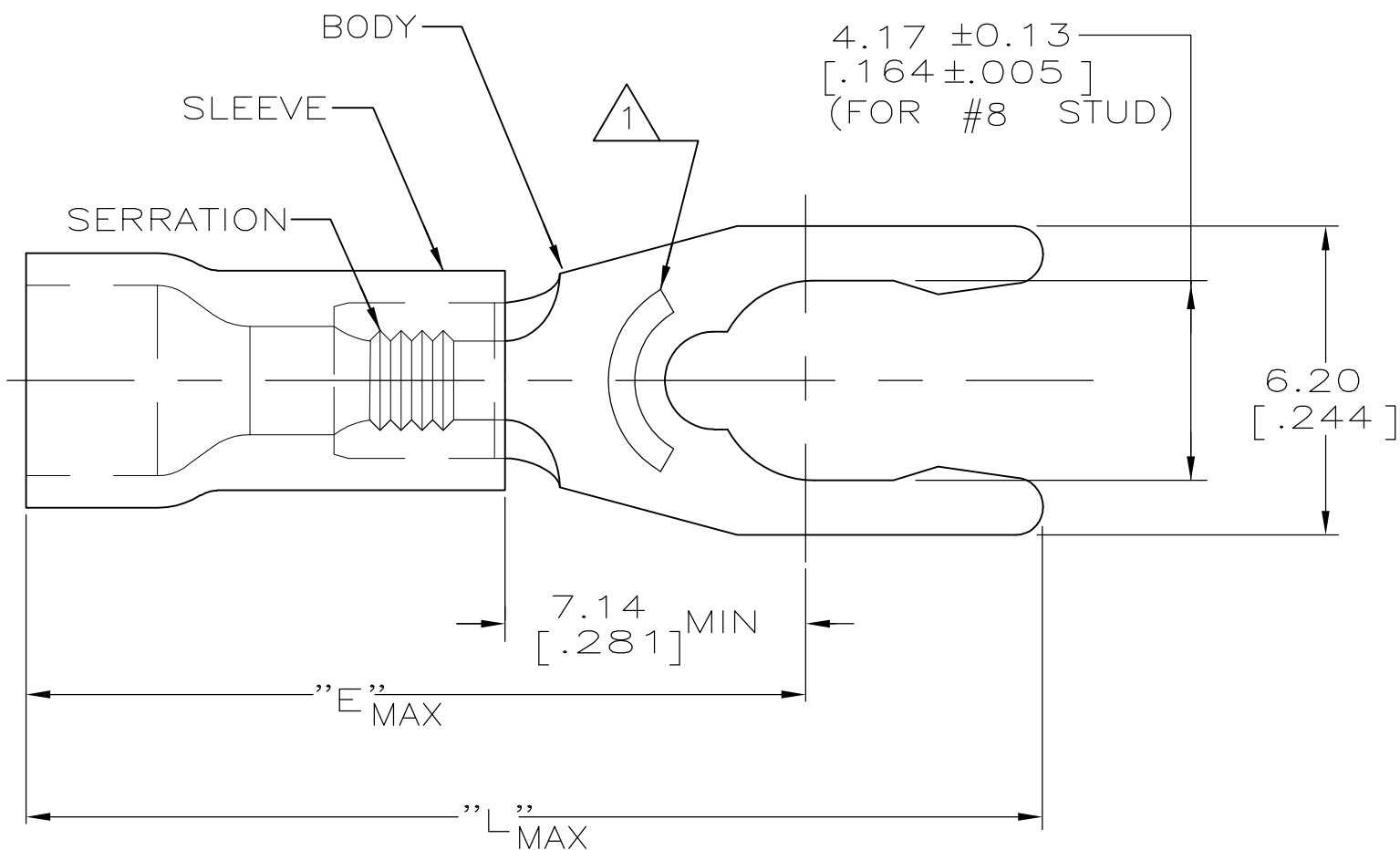

- ① STAMP 8SAMP 16-14\* APPROX AS SHOWN
- 2. SEE TABLE FOR WIRE INSUL DIA
- 3. TONGUE MATL THK, 0.79±0.05 [.031±.002]
- ④ MATERIAL: BODY - BRASS PER ASTM B-36  
SLEEVE - PVC, COLOR - BLUE

|                 |                 |                          |      |                  |           |
|-----------------|-----------------|--------------------------|------|------------------|-----------|
| 22.15<br>[.872] | 17.70<br>[.697] | 3.00-4.90<br>[.118-.193] | 100  | LOOSE PIECE, BOX | 8-53244-1 |
| 23.39<br>[.921] | 18.95<br>[.746] | 3.81-6.35<br>[.150-.250] | 2500 | ON TAPE, REEL    | 53244-4   |
| 22.15<br>[.872] | 17.70<br>[.697] | 3.00-4.90<br>[.118-.193] | 5000 | ON TAPE, REEL    | 53244-2   |
| 22.15<br>[.872] | 17.70<br>[.697] | 3.00-4.90<br>[.118-.193] | 1000 | LOOSE PIECE      | 53244-1   |
| L               | E               | WIRE INSUL DIA           | QTY  | PACKAGE TYPE     | PART NO   |

**AMP INCORPORATED  
CUSTOMER SERVICE SYSTEMS**

FOR ADDITIONAL PRODUCT INFORMATION OR COPIES OF DRAWINGS AND TECHNICAL DOCUMENTS: PRODUCT INFORMATION CENTER 1-800-522-6752

FOR APPLICATION TOOLING ASSISTANCE CENTER: TOOLING ASSISTANCE CENTER 1-800-722-1111

FOR ORDER ENTRY: 1-800-526-5142

MAX RECOMMENDED OPERATING TEMPERATURE: 105°C [221° F]

VOLTAGE RATING: 600V MAX (1000V FIXTURE OR SIGN)

CIRCULAR MIL AREA: 1.04-2.62mm² [2,050-5,180] SOLID OR STRANDED

THIS DRAWING IS A CONTROLLED DOCUMENT FOR AMP INCORPORATED. IT IS SUBJECT TO CHANGE AND THE CONTROLLING ENGINEERING ORGANIZATION SHOULD BE CONTACTED FOR THE LATEST REVISION.

THIS DRAWING IS A CONTROLLED DOCUMENT.

DIMENSIONS: mm [INCHES]

TOLERANCES UNLESS OTHERWISE SPECIFIED:

|        |               |
|--------|---------------|
| 0 PLC  | ± -           |
| 1 PLC  | ± -           |
| 2 PLC  | ± 0.20 [.008] |
| 3 PLC  | ± -           |
| 4 PLC  | ± -           |
| ANGLES | ± -           |

MATERIAL: TIN PER ASTM B545

DWN: L OLMEDA 26JUN95  
 CHK: M ELLIS 26JUN95  
 APVD: G NGO 26JUN95

**Tyco Electronics**  
 Tyco Electronics Corporation  
 Harrisburg, Pa 17105-3608

NAME: TERMINAL, SPRING SPADE, SHORT, PLASTI-GRIP, WIRE SIZE: 16-14

PRODUCT SPEC: UL 486A

APPLICATION SPEC: -

WEIGHT: -

SIZE: A3 CAGE CODE: 00779 DRAWING NO: C-53244 RESTRICTED TO: -

CUSTOMER DRAWING SCALE: 6:1 SHEET: 1 OF 1 REV: L