



Chipsmall Limited consists of a professional team with an average of over 10 year of expertise in the distribution of electronic components. Based in Hongkong, we have already established firm and mutual-benefit business relationships with customers from,Europe,America and south Asia,supplying obsolete and hard-to-find components to meet their specific needs.

With the principle of “Quality Parts,Customers Priority,Honest Operation,and Considerate Service”,our business mainly focus on the distribution of electronic components. Line cards we deal with include Microchip,ALPS,ROHM,Xilinx,Pulse,ON,Everlight and Freescale. Main products comprise IC,Modules,Potentiometer,IC Socket,Relay,Connector.Our parts cover such applications as commercial,industrial, and automotives areas.

We are looking forward to setting up business relationship with you and hope to provide you with the best service and solution. Let us make a better world for our industry!



Contact us

Tel: +86-755-8981 8866 Fax: +86-755-8427 6832

Email & Skype: info@chipsmall.com Web: www.chipsmall.com

Address: A1208, Overseas Decoration Building, #122 Zhenhua RD., Futian, Shenzhen, China



Model 5325A
DMM Test Probe to Multi-Stacking Banana Plug Kit

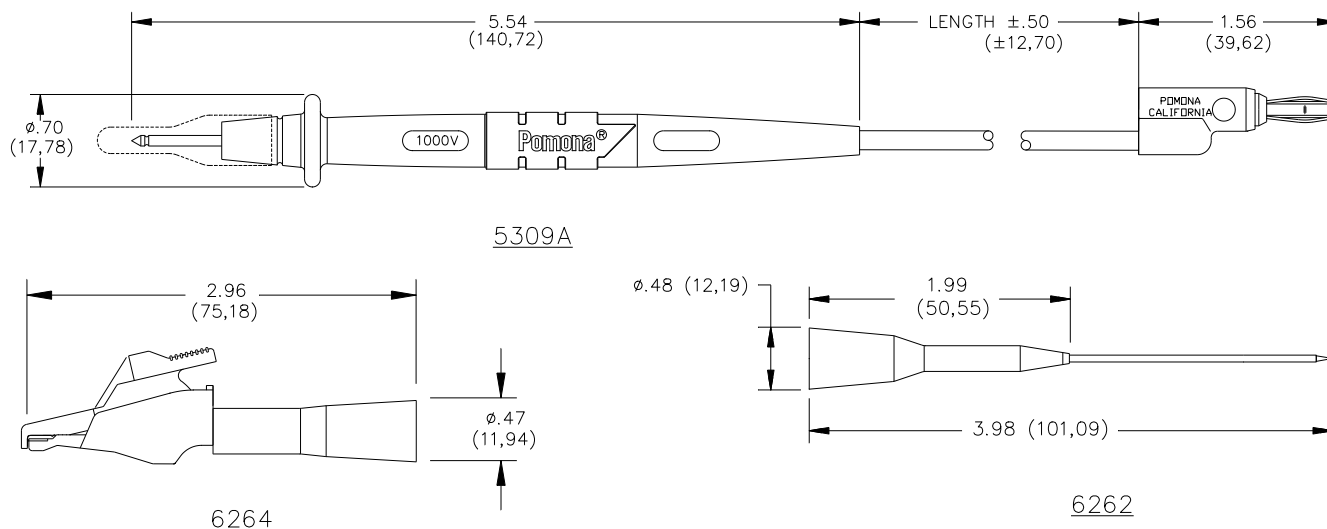

FEATURES

- Fits Fluke, H-P, Tektronix Wavetek and Amprobe meters configured with non-sheathed standard and 4 mm banana jacks.
- Test probe & banana plug bodies are molded directly to a flexible 48" (122 cm) high strand count/high temperature silicone leads for added pull strength, overall probe length 4.85" (12,3 cm).
- Wear indication with double insulated (dual extruded) silicone leads shows white inner layer for increased safety.
- Nickel plated brass tip offers high conductivity for precision measurements.
- Medium alligators are insulated for added safety and can quickly snap onto the .080" (2,03 mm) O.D. probe tip.
- Medium alligators have an overall length of 2.25" (5.7 cm) and grip up to 0.30" (7.62 mm) O.D. terminals.
- Slide-on extended tips have an overall length of 4" (10.16 cm) & attaches to the probe tip to allow access to hard to reach test points. The Extended Tip is insulated to the point to prevent accidental shorting.



USA: Sales: 800-490-2361
 Technical Support: technicalsupport@pomonatest.com
 Fax: 425-446-5844
Europe: 31-(0) 40 2675 150 **International:** 425-446-5500
Where to Buy: www.pomonaelectronics.com

All dimensions are in inches. Tolerances (except noted): .xx = ±.02" (.51 mm), .xxx = ±.005" (.127 mm). All specifications are to the latest revisions. Specifications are subject to change without notice. Registered trademarks are the property of their respective companies.

Model 5325A
DMM Test Probe To Multi-Stacking Banana Plug Kit**MATERIALS**

Model **5309A**: Test Probe Set:

Probe body: Polypropylene, Fire Retardant – Santoprene® overmold., Tip: Brass

Wire: 18 AWG, 192 x 41 bare copper, Silicone Insulation, O.D. 0.144" (3,66mm). Length: 48" (122cm)

Banana Plug: Insulation: Polypropylene – Plug Body: Brass Nickel Plated, Spring: Beryllium Copper, Nickel Plated

RATINGS:

Operating Voltage: For CE compliance and personal safety, do not hold in hand when voltages exceed 30 Vrms/42.4 Vpk/60 Vdc or current exceeds 8A maximum. Maximum voltage for hands free use: 1000 V. Do not use on circuits where transient stresses can exceed the rated voltage.

Current: 10 Amperes

Model **6262**: Slide-on Extended Tip:

Insulation – Polypropylene UL94 V-2, Color: one black and one red

Probe Tip: Stainless Steel with Kynar Insulation Sleeve to Tip End

RATINGS: CAT II 300 V, Current: 3 Amperes

Model **6264**: Alligator Adapter:

Insulation: Polypropylene, Color: One Black, One Red

Body: Steel, Nickel Plated, Spring: Music Wire

RATINGS: CAT I 300 V, Current: 5 Amperes

Ordering Information: Model 5325A

Kit shipped in a plastic blister package.

Replacement P/N's:

- Model **5309A**: Test Probes, set of one black and one red
- Model **6262**: Slide-on Extended Tip, set of one black and one red
- Model **6264**: Alligator Adapter, set of one black and one red.

USA: Sales: 800-490-2361
Technical Support: technicalsupport@pomonatest.com
Fax: 425-446-5844

Europe: 31-(0) 40 2675 150 **International:** 425-446-5500

Where to Buy: www.pomonaelectronics.com

All dimensions are in inches. Tolerances (except noted): .xx = ±.02" (.51 mm), .xxx = ±.005" (.127 mm). All specifications are to the latest revisions. Specifications are subject to change without notice. Registered trademarks are the property of their respective companies.