



Chipsmall Limited consists of a professional team with an average of over 10 year of expertise in the distribution of electronic components. Based in Hongkong, we have already established firm and mutual-benefit business relationships with customers from,Europe,America and south Asia,supplying obsolete and hard-to-find components to meet their specific needs.

With the principle of “Quality Parts,Customers Priority,Honest Operation,and Considerate Service”,our business mainly focus on the distribution of electronic components. Line cards we deal with include Microchip,ALPS,ROHM,Xilinx,Pulse,ON,Everlight and Freescale. Main products comprise IC,Modules,Potentiometer,IC Socket,Relay,Connector.Our parts cover such applications as commercial,industrial, and automotives areas.

We are looking forward to setting up business relationship with you and hope to provide you with the best service and solution. Let us make a better world for our industry!



Contact us

Tel: +86-755-8981 8866 Fax: +86-755-8427 6832

Email & Skype: info@chipsmall.com Web: www.chipsmall.com

Address: A1208, Overseas Decoration Building, #122 Zhenhua RD., Futian, Shenzhen, China



LOC		DIST		REVISIONS			
AD	00	REV	DATE	BY	CHK	APP	
B		REVISED PER ECO-08-006412	12MAR08	DH	JE		
C		ECR-10-019054	15SEP10	DP	MQW		

CONNECTOR ASSEMBLY EXAMPLARY LOADED

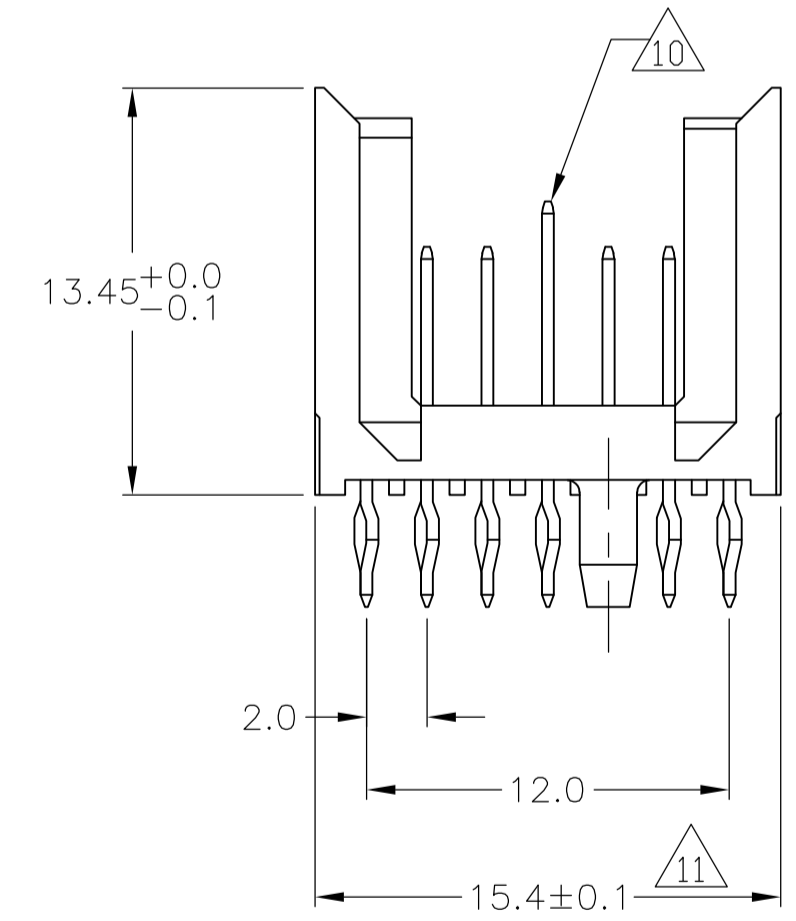
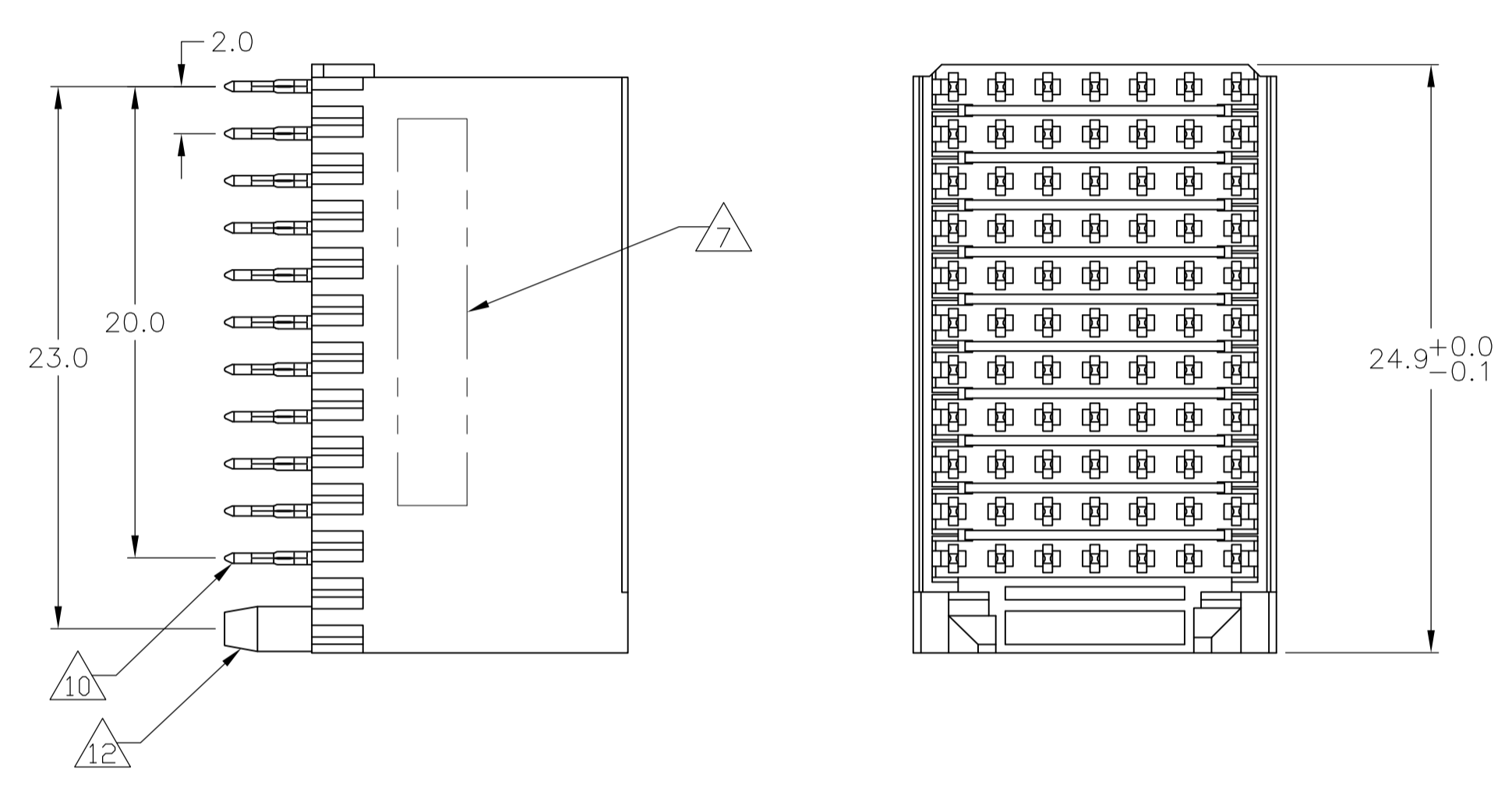

CONTACT DIMENSIONS

SCALE 5:1

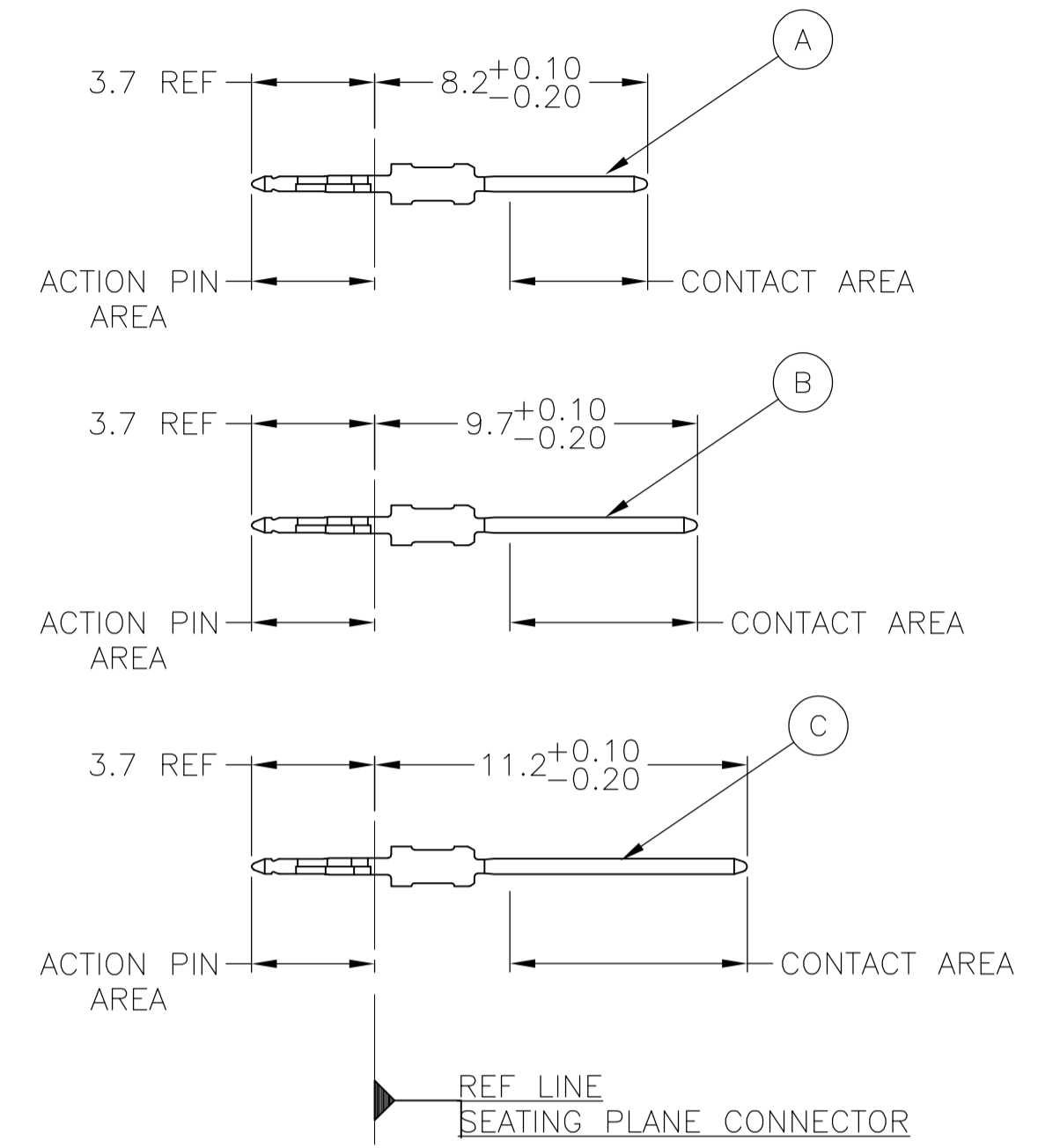

CONTACT LAYOUT

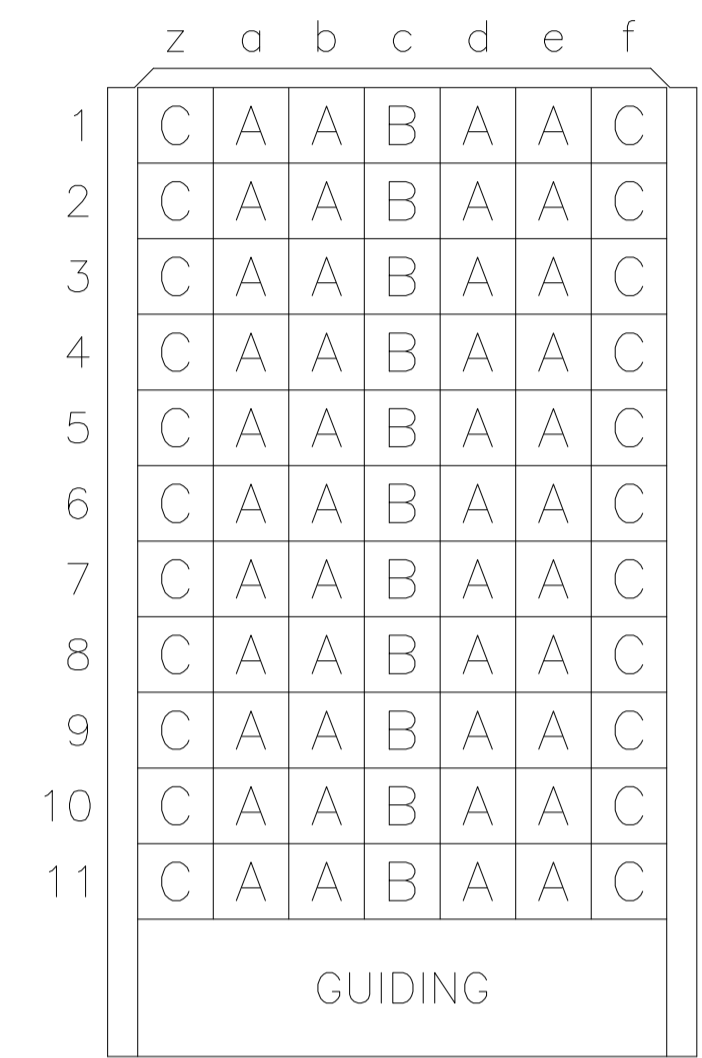

RECOMMENDED PCB-HOLE LAYOUT COMPONENT SIDE SHOWN

PLATED THRU HOLES PARAMETERS REFERENCE APPLICATION SPECIFICATION

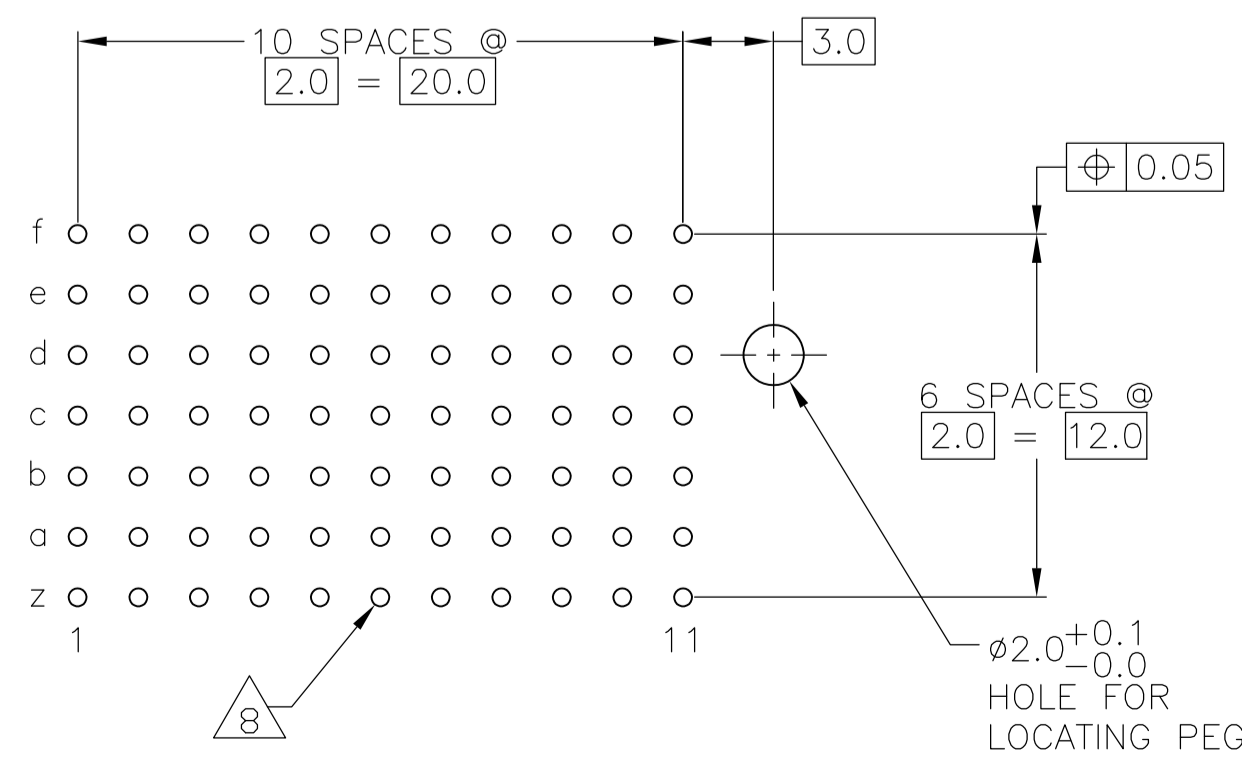

2 6 13	1-5352452-9
2 5 13	5352452-9
2 4	5352452-4
2 3	5352452-1
FINISH	PART NUMBER

THIS DRAWING IS A CONTROLLED DOCUMENT.		DIN B CARBO 31AUG05		Tyco Electronics Corporation	
DIMENSIONS: mm		GSKIPPER 31AUG05		Harrisburg, Pa 17105-3608	
TOLERANCES UNLESS OTHERWISE SPECIFIED:		GSKIPPER 31AUG05		Tyco Electronics	
0-PLC ±		NAME		MALE ASSEMBLY, Z-PACK 2mm HM, TYPE C	
1-PLC ±0.2		APPLICATION SPEC		108-19082	
2-PLC ±0.002		APPLICATION SPEC		114-19029	
3-PLC ±0.005		SIZE		A1	
4-PLC ±0.010		CAGE CODE		00779	
ANGLES ±0.30°		DRAWING NO		5352452	
MATERIAL		WEIGHT		CUSTOMER DRAWING	
FINISH SEE TABLE		SCALE		4:1	
1		SHEET		1 OF 2	
		REV		C	

LOC	DIST	REVISIONS			
P	LTR	DESCRIPTION	DATE	DN	APVD
AD	00	SEE SHEET 1	-	-	-

- 1 MATERIAL:
CONTACT: PHOSPHOR BRONZE.
HOUSING: GLASS-FILLED POLYESTER.
- 2 GENERAL PLATING SPECIFICATION: UNDERPLATING
(ENTIRE CONTACT): 1.27µm MIN NICKEL AND ACTION
PIN: 0.5µm MIN TIN.
FOR PLATING OF MATING SURFACES SEE APPLICABLE
SPECIFICATION REFERENCE FOR EACH DASH NUMBER.
- 3 CONFORMS TO ALL TESTING ACCORDING TO IEC 61076-4-101
PERFORMANCE LEVEL 2.
- 4 CONFORMS TO ALL TESTING ACCORDING TO IEC 61076-4-101
PERFORMANCE LEVEL 1.
- 5 CONNECTOR TESTED AND QUALIFIED AGAINST TELCORDIA GR-1217-CORE QUALITY LEVEL 3,
CENTRAL OFFICE APPLICATIONS.
- 6 CONNECTOR TESTED AND QUALIFIED AGAINST TELCORDIA GR-1217-CORE QUALITY LEVEL 3,
UNCONTROLLED ENVIROMENT APPLICATIONS.
- 7 CONNECTOR MARKED WITH PART NUMBER AND DATE CODE.
ADDITIONAL CHARACTERS OR MARKINGS, AS WELL AS THE LOCATION OF THE MARKINGS,
MAY BE ADDED FOR TRACEABILITY BASED UPON MANUFACTURERS DISCRETION.
- 8 PLATED-THROUGH HOLES AT 2x2mm SQUARE GRID
PATTERN DEFINED BY CONTACT LAYOUT.
- 9 FOR ACTUAL PIN LOADING SEE "CONTACT LAYOUT".
- 10 FOR ACTUAL PIN DIMENSIONS SEE "CONTACT DIMENSIONS".
- 11 TO BE MEASURED AT BOTTOM OF SHROUD.
- 12 LOCATION PEG.
- 13 CONNECTOR LUBRICATED WITH BELCORE APPROVED LUBRICANT,
TECHNICAL REFERENCE: TR-NWT-001217 ISSUE 1, SEP 1992.

THIS DRAWING IS A CONTROLLED DOCUMENT.		DIN B CARBO	31AUG05	 Tyco Electronics Corporation Harrisburg, Pa 17105-3608
		CHK G SKIPPER	31AUG05	
		APVD G SKIPPER	31AUG05	NAME
		PRODUCT SPEC		
		108-19082		
		APPLICATION SPEC		
		114-19029		
		RESTRICTED TO		
MATERIAL SEE SHEET 1		FINISH SEE SHEET 1		WEIGHT -
		SIZE A1		CAGE CODE 00779
		DRAWING NO 5352452		REV C
		CUSTOMER DRAWING		SCALE 4:1
		SHEET 2		OF 2