



Chipsmall Limited consists of a professional team with an average of over 10 year of expertise in the distribution of electronic components. Based in Hongkong, we have already established firm and mutual-benefit business relationships with customers from,Europe,America and south Asia,supplying obsolete and hard-to-find components to meet their specific needs.

With the principle of "Quality Parts,Customers Priority,Honest Operation,and Considerate Service",our business mainly focus on the distribution of electronic components. Line cards we deal with include Microchip,ALPS,ROHM,Xilinx,Pulse,ON,Everlight and Freescale. Main products comprise IC,Modules,Potentiometer,IC Socket,Relay,Connector.Our parts cover such applications as commercial,industrial, and automotives areas.

We are looking forward to setting up business relationship with you and hope to provide you with the best service and solution. Let us make a better world for our industry!



## Contact us

Tel: +86-755-8981 8866 Fax: +86-755-8427 6832

Email & Skype: info@chipsmall.com Web: www.chipsmall.com

Address: A1208, Overseas Decoration Building, #122 Zhenhua RD., Futian, Shenzhen, China



THIS DRAWING IS UNPUBLISHED. RELEASED FOR PUBLICATION  
 © COPYRIGHT - By - ALL RIGHTS RESERVED.

REVISIONS				DATE	DWN	APVD
P	LTR	DESCRIPTION				
C		REVISED PER ECO-13-015151	16DEC2013	FL	FY	

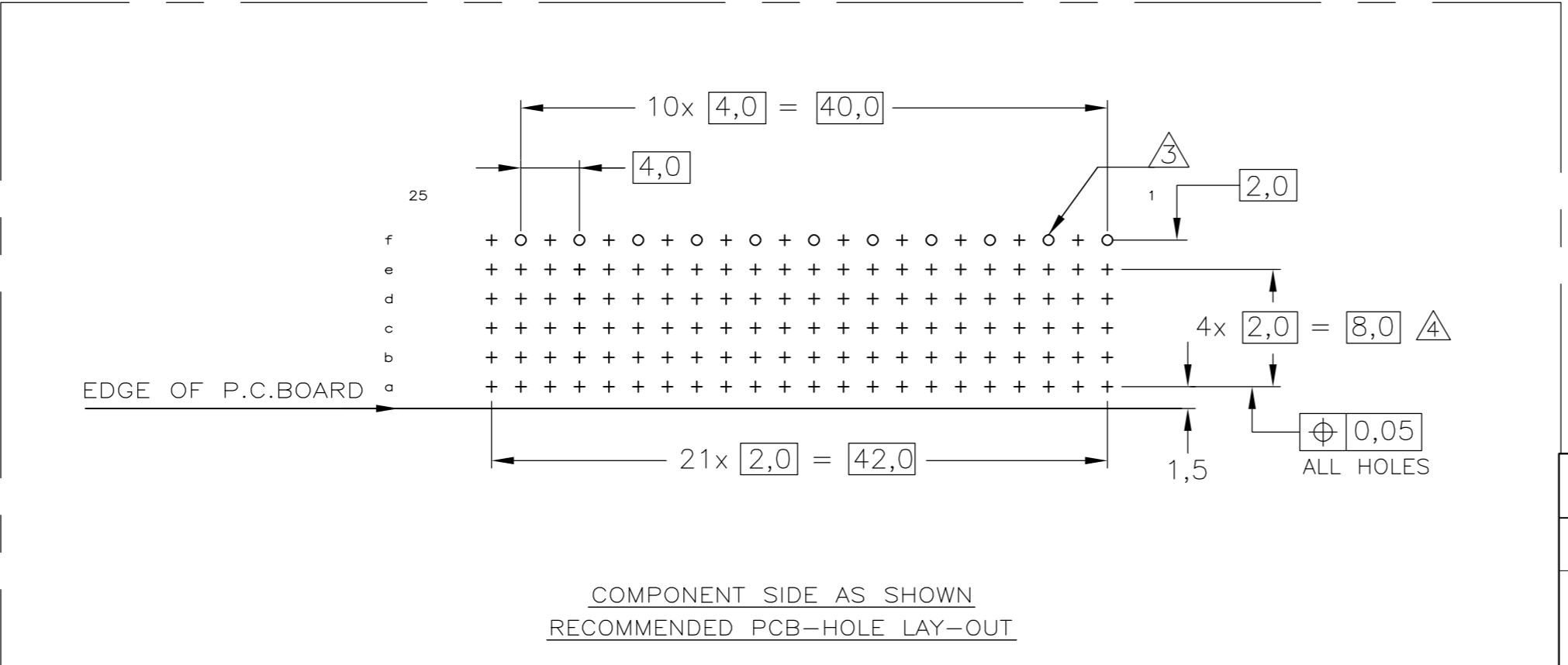
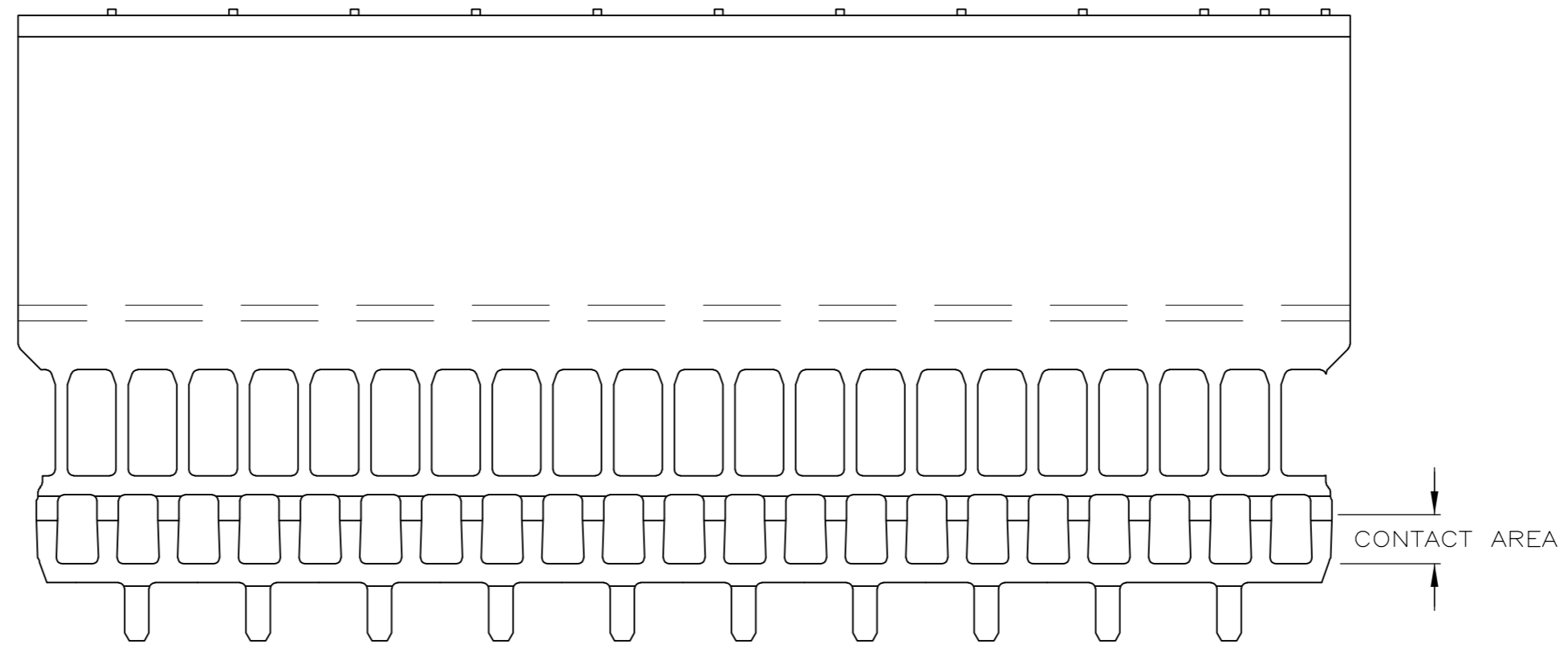
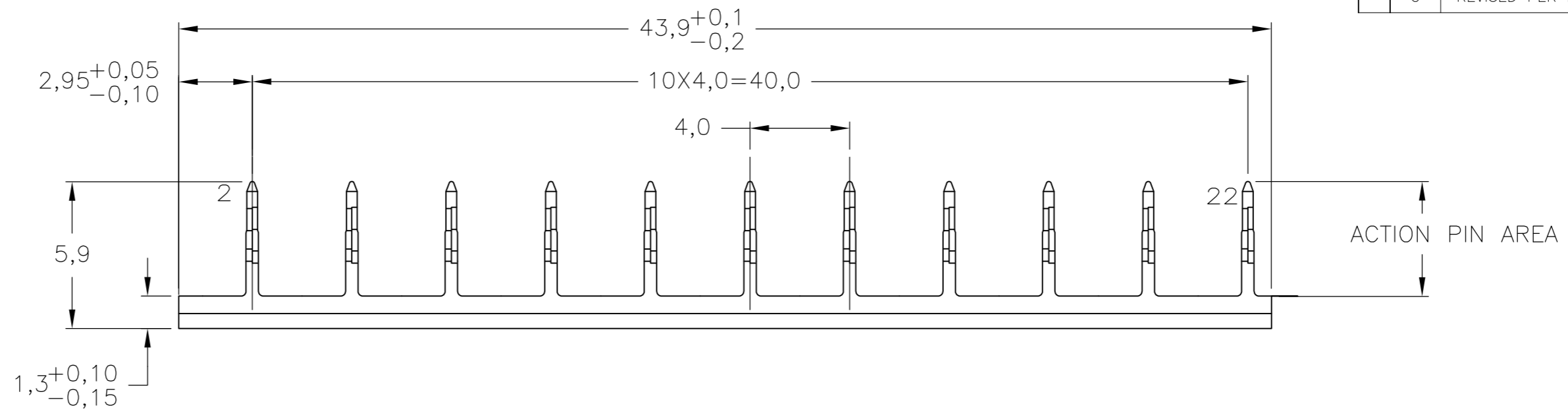
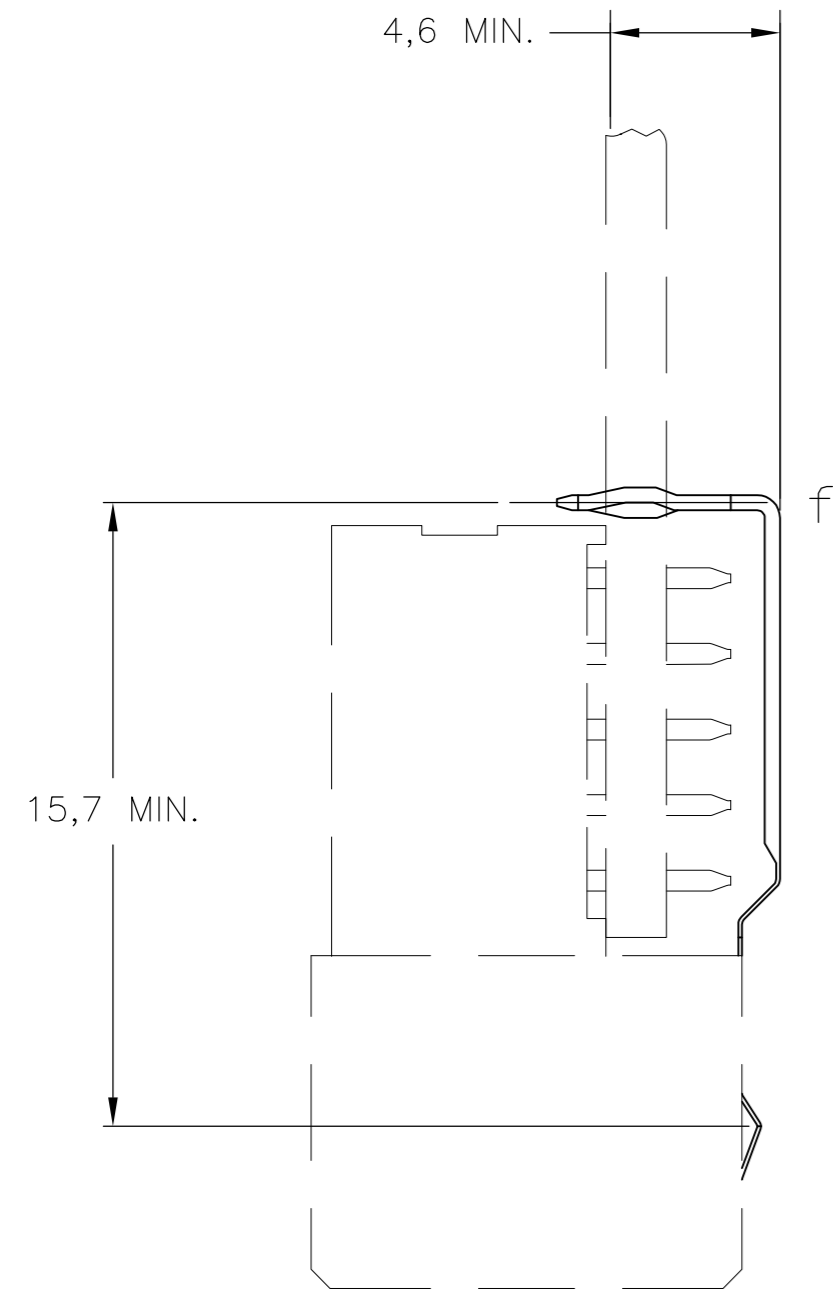

**NOTES:**

- 1 GENERAL PLATING SPECIFICATION: UNDERPLATING (ENTIRE CONTACT): 1,27µm NICKEL MIN. AND ACTION PIN: 0,5µm TIN MIN. FOR PLATING OF MATING SURFACES SEE PERFORMANCE LEVEL SHOWN IN PART NUMBER TABLE.
- 2 MATERIAL; PHOSPHORBRONZE.
- 3 ROW "f" 11 PLATED THROUGH HOLES FOR LOWERSHIELD.
- 4 HOLE PATTERN FOR FEMALE CONNECTOR TYPE B-22 COLUMNS WITH UPPERSHIELD, 110+11 PLATED-THROUGH HOLES AT 2x2mm SQUARE GRID MAX. BOARD THICKNESS 3,5 mm.
- 5 SHIELDS LUBRICATED WITH BELLCORE APPROVED LUBRICANT. TECHNICAL REF: TR-NWT-001217 ISSUE 1, SEPT. 1992.
- 6 CONFORMS TO ALL TESTING ACCORDING IEC 61076-4-101 PERFORMANCE LEVEL 2.
- 7 CONFORMS TO ALL TESTING ACCORDING IEC 61076-4-101 PERFORMANCE LEVEL 1.
- 8 CONNECTOR TESTED AND QUALIFIED AGAINST TELCORDIA GR-1217-CORE QUALITY LEVEL III, CENTRAL OFFICE APPLICATIONS.
- 9 0,76µm MIN GOLD PLATING AT MATING SURFACE.

FINISH	MATERIAL	PARTNUMBER
1 2 3	2	4-5352468-0
1 6 9	2	5352468-9
1 1	2	5352468-2

THIS DRAWING IS A CONTROLLED DOCUMENT.		DWN B. Mooij 08-JUL-05			NAME	
DIMENSIONS: mm		CHK B. Mooij 08-JUL-05			Z-PACK 2mm HM	
TOLERANCES UNLESS OTHERWISE SPECIFIED:		APVD J. Broeksteeg 08-JUL-05	GROUND RETURN LOWERSHIELD		RESTRICTED TO	
0-PLC ±		PRODUCT SPEC	TYPE B-22 COLUMNS			
1-PLC ± ±0.2		APPLICATION SPEC	SIZE A2	CAGE CODE 00779	DRAWING NO. C=5352468	
2-PLC ±		WEIGHT	SCALE 5:1	SHEET 1 of 1	REV C	
3-PLC ±		CUSTOMER DRAWING				
4-PLC ±						
ANGLES ±						
FINISH						