



Chipsmall Limited consists of a professional team with an average of over 10 year of expertise in the distribution of electronic components. Based in Hongkong, we have already established firm and mutual-benefit business relationships with customers from,Europe,America and south Asia,supplying obsolete and hard-to-find components to meet their specific needs.

With the principle of “Quality Parts,Customers Priority,Honest Operation,and Considerate Service”,our business mainly focus on the distribution of electronic components. Line cards we deal with include Microchip,ALPS,ROHM,Xilinx,Pulse,ON,Everlight and Freescale. Main products comprise IC,Modules,Potentiometer,IC Socket,Relay,Connector.Our parts cover such applications as commercial,industrial, and automotives areas.

We are looking forward to setting up business relationship with you and hope to provide you with the best service and solution. Let us make a better world for our industry!



## Contact us

Tel: +86-755-8981 8866 Fax: +86-755-8427 6832

Email & Skype: info@chipsmall.com Web: www.chipsmall.com

Address: A1208, Overseas Decoration Building, #122 Zhenhua RD., Futian, Shenzhen, China



THIS DRAWING IS UNPUBLISHED. RELEASED FOR PUBLICATION  
 © COPYRIGHT - BY TYCO ELECTRONICS CORPORATION. ALL RIGHTS RESERVED.

LOC	DIST	REVISIONS				
P	LTR	DESCRIPTION	DATE	DWN	APVD	
G	14	K	REV PER 0G3A-0582-04	31AUG04	JR	TM

**AMP**  
WIRE RANGE

---

22-16 AWG  
STRANDED

- 1 WIRE INSULATION DIA 2.03 [.080] TO 3.18 [.125].
- △2 FINISH: BODY AND SLEEVE: TIN/LEAD (93-7) PLATE PER ASTM B545. (3% MIN LEAD CONTENT)
- △3 MATERIAL: BODY AND SLEEVE, COPPER PER ASTM B152  
INSULATION: PVF<sup>2</sup>  
COLOR- NATURAL
- 4 MARKING 22-18 FOR MILITARY; COMMERCIAL RANGE 22-16

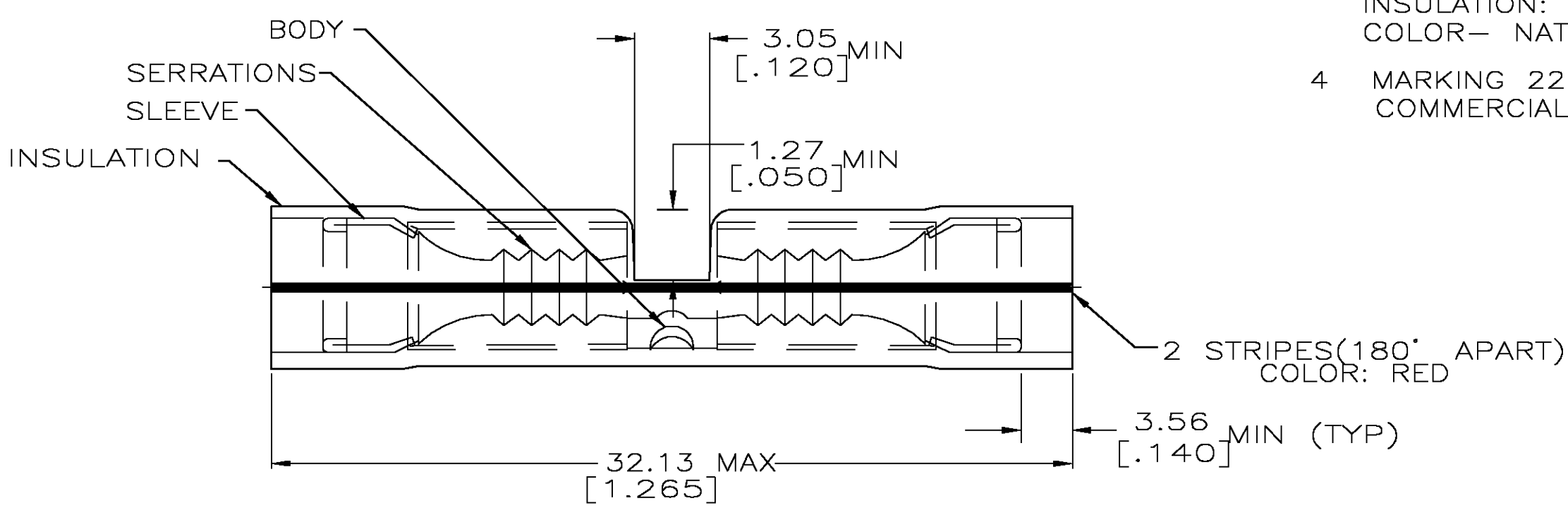

MILITARY PART NUMBER & CLASS PER MIL-T-7928	QTY	PACKAGE TYPE	PART NO.
-	25	LOOSE PIECE, BOX	8-53548-3
M7928/6-3 CLASS 2	2500	ON TAPE	53548-2
M7928/6-3 CLASS 1 & 2	1000	LOOSE PIECE	53548-1

**AMP INCORPORATED**  
**CUSTOMER SERVICE SYSTEMS**

FOR ADDITIONAL PRODUCT INFORMATION OR COPIES OF DRAWINGS AND TECHNICAL DOCUMENTS  
 PRODUCT INFORMATION CENTER  
 1-800-522-6752

FOR APPLICATION TOOLING ASSISTANCE CENTER  
 TOOLING INFORMATION  
 1-800-722-1111

FOR ORDER ENTRY  
 1-800-526-5142

MAX RECOMMENDED OPERATING TEMPERATURE:  
150°C

VOLTAGE RATING:  
-

CIRCULAR MIL AREA:  
0.26-1.65mm<sup>2</sup> [509-3,260] STRANDED

THIS DRAWING IS A CONTROLLED DOCUMENT FOR AMP INCORPORATED. IT IS SUBJECT TO CHANGE AND THE CONTROLLING ENGINEERING ORGANIZATION SHOULD BE CONTACTED FOR THE LATEST REVISION.

THIS DRAWING IS A CONTROLLED DOCUMENT.

DIMENSIONS: MM [ INCHES ]

TOLERANCES UNLESS OTHERWISE SPECIFIED:

0 PLC	± -
1 PLC	± -
2 PLC	± 0.20 [.008]
3 PLC	± -
4 PLC	± -
ANGLES	± -
FINISH	△2

MATERIAL: - △3

DWN S.S. GOULDEN 9-28-93  
 CHK R. HERSEY 9-28-93  
 APVD M ELLIS 9-28-93

**tyco Electronics** Tyco Electronics Corporation  
 Harrisburg, Pa 17105-3608

NAME: SPLICE, BUTT, PVF<sup>2</sup>, P.I.D.G., WIRE SIZE: 22-16 AWG

PRODUCT SPEC: 108-11023

APPLICATION SPEC: -

SIZE: A3 CAGE CODE: 00779 DRAWING NO: C-53548 RESTRICTED TO: -

WEIGHT: -

CUSTOMER DRAWING SCALE: 1:1 SHEET: 1 OF 1 REV: K