



Chipsmall Limited consists of a professional team with an average of over 10 year of expertise in the distribution of electronic components. Based in Hongkong, we have already established firm and mutual-benefit business relationships with customers from,Europe,America and south Asia,supplying obsolete and hard-to-find components to meet their specific needs.

With the principle of “Quality Parts,Customers Priority,Honest Operation,and Considerate Service”,our business mainly focus on the distribution of electronic components. Line cards we deal with include Microchip,ALPS,ROHM,Xilinx,Pulse,ON,Everlight and Freescale. Main products comprise IC,Modules,Potentiometer,IC Socket,Relay,Connector.Our parts cover such applications as commercial,industrial, and automotives areas.

We are looking forward to setting up business relationship with you and hope to provide you with the best service and solution. Let us make a better world for our industry!



## Contact us

Tel: +86-755-8981 8866 Fax: +86-755-8427 6832

Email & Skype: info@chipsmall.com Web: www.chipsmall.com

Address: A1208, Overseas Decoration Building, #122 Zhenhua RD., Futian, Shenzhen, China



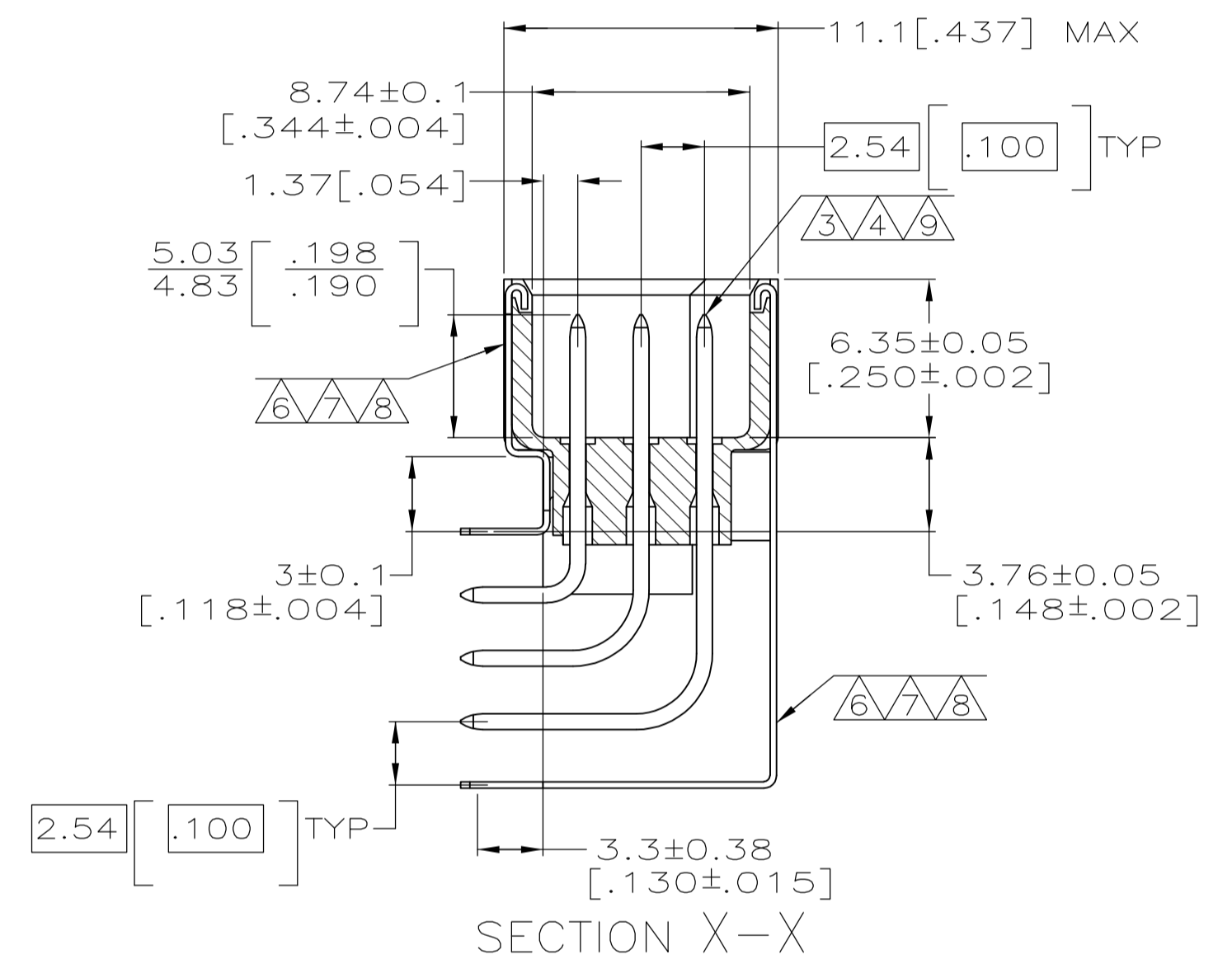
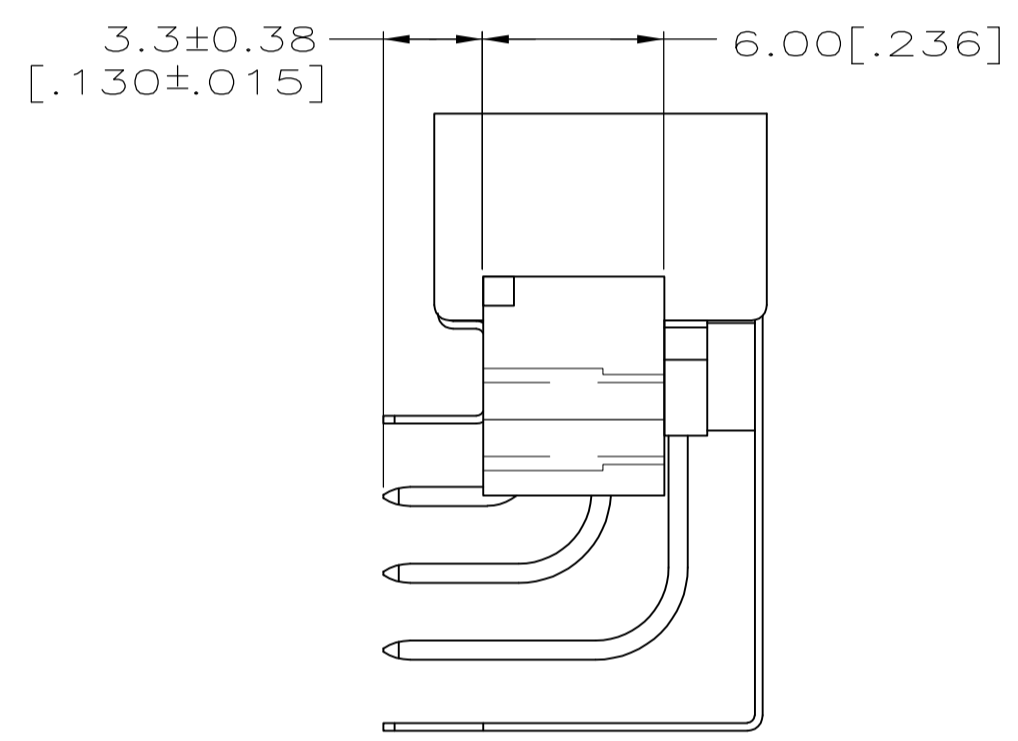
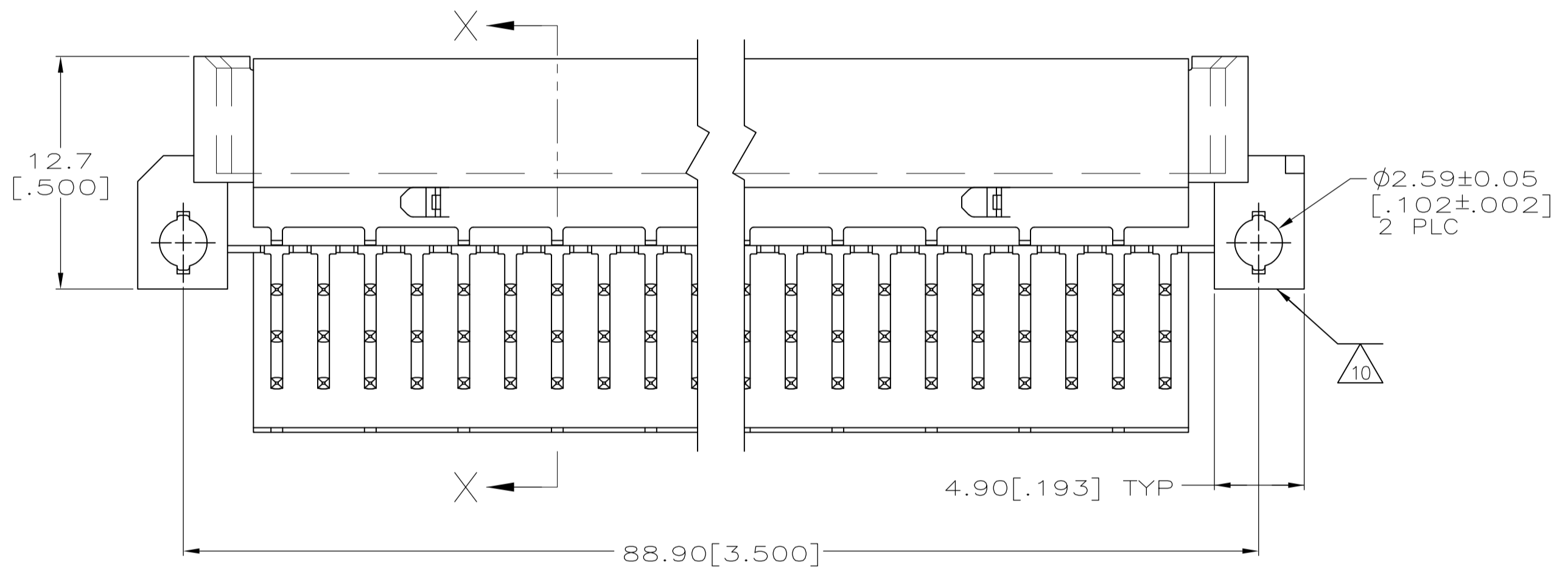
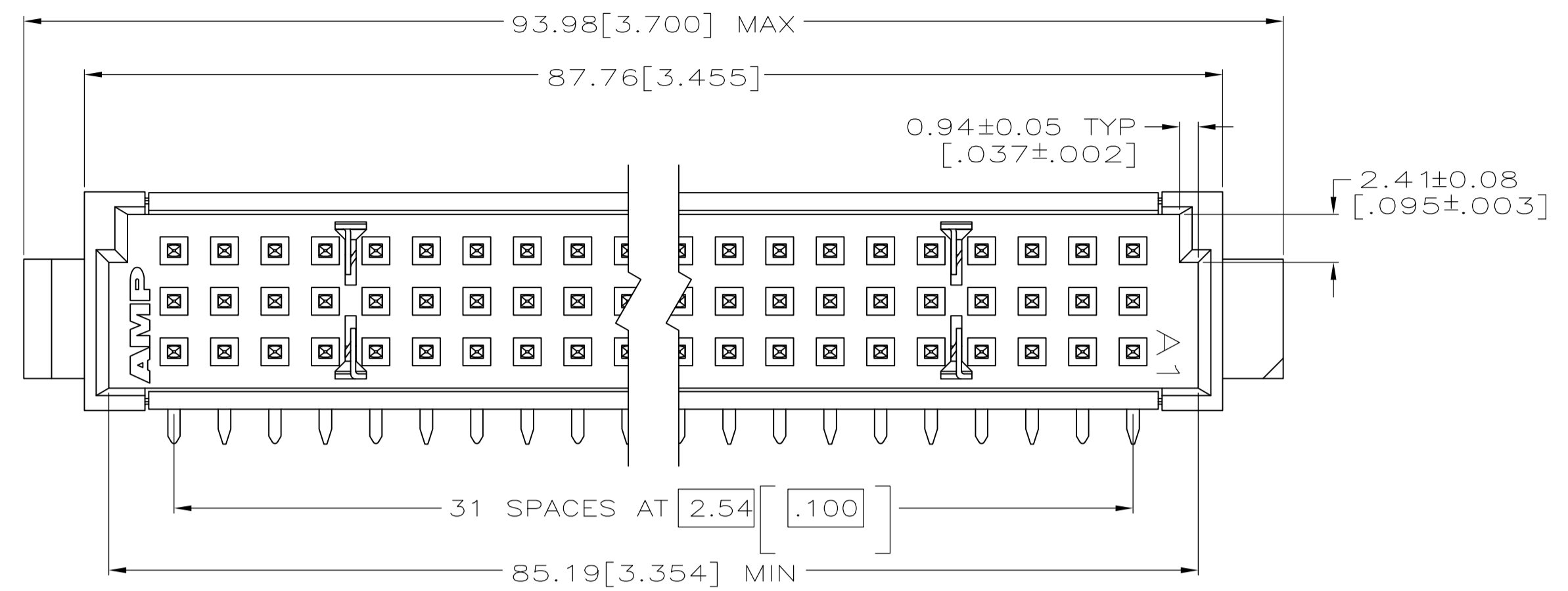

- 1 HOUSING MATERIAL: HIGH TEMPERATURE, GLASS-FILLED POLYMER  
COLOR: GRAY OR WHITE
- 2 POST AND GROUND PLATE MATERIAL: BRASS.
- 3 POST FINISH: DIN 41612 CLASS 2 IN CONTACT AREA.  
TIN-LEAD PLATE ON POSTS.
- 4 POST FINISH: DIN 41612 CLASS 3 IN CONTACT AREA.  
TIN-LEAD PLATE ON POSTS.
- 5 RECOMMENDED HOLE SIZE FOR MANUAL APPLICATION OF  
CONNECTOR ONTO PC BOARD.
- 6 GROUND PLATE FINISH: DIN 41612 CLASS 2 IN CONTACT AREA.  
TIN-LEAD PLATE ON POSTS.
- 7 GROUND PLATE FINISH: DIN 41612 CLASS 3 IN CONTACT AREA.  
TIN-LEAD PLATE ON POSTS.
- 8 GROUND PLATE FINISH: 0.00127[.000050] GOLD IN CONTACT AREA.  
0.00127[.000050] NICKEL UNDERPLATE ALL OVER. TIN-LEAD PLATE ON POSTS.
- 9 POST FINISH: 0.00127[.000050] GOLD IN CONTACT AREA.  
0.00127[.000050] NICKEL UNDERPLATE ALL OVER. TIN-LEAD PLATE ON POSTS.
- 10 MOLD REVISION DATE CODE MOLDED IN THIS AREA.
- 11 OBSOLETE PART NUMBER.

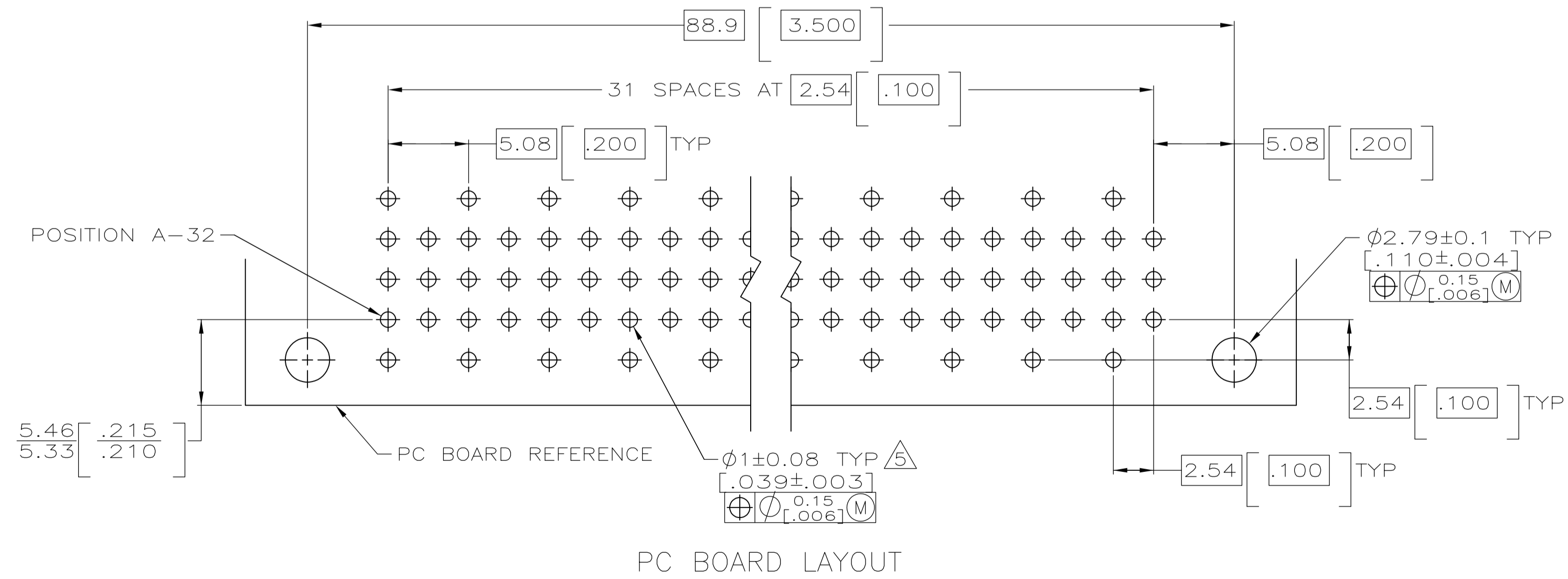

11	4	536146-9
	3	536146-5
	8	536146-1
	FINISH	ASSY PART NUMBER

THIS DRAWING IS A CONTROLLED DOCUMENT.		DIN L. BRINER 2/24/92	Tyco Electronics Corporation Harrisburg, PA 17105-3608	
DIMENSIONS: INCHES		CHK: D.C. RUBENDALL	NAME: PIN ASSEMBLY, ENHANCED EUROCARD WITH TWO EXTERNAL PLATES	
TOLERANCES UNLESS OTHERWISE SPECIFIED:		APVD: -	PRODUCT SPEC: -	
0 PLC ± - 1 PLC ± - 2 PLC ± - 3 PLC ± 0.1[.005] 4 PLC ± - ANGLES ± -		APPLICATION SPEC: -	RESTRICTED TO: -	
MATERIAL: HSG: △	FINISH: △△△	WEIGHT: -	SIZE: A1	CAGE CODE: 00779
POST: △	GROUND PLATE: △△△	CUSTOMER DRAWING	SCALE: 4:1	SHEET 1 OF 1