



Chipsmall Limited consists of a professional team with an average of over 10 year of expertise in the distribution of electronic components. Based in Hongkong, we have already established firm and mutual-benefit business relationships with customers from,Europe,America and south Asia,supplying obsolete and hard-to-find components to meet their specific needs.

With the principle of “Quality Parts,Customers Priority,Honest Operation,and Considerate Service”,our business mainly focus on the distribution of electronic components. Line cards we deal with include Microchip,ALPS,ROHM,Xilinx,Pulse,ON,Everlight and Freescale. Main products comprise IC,Modules,Potentiometer,IC Socket,Relay,Connector.Our parts cover such applications as commercial,industrial, and automotives areas.

We are looking forward to setting up business relationship with you and hope to provide you with the best service and solution. Let us make a better world for our industry!



Contact us

Tel: +86-755-8981 8866 Fax: +86-755-8427 6832

Email & Skype: info@chipsmall.com Web: www.chipsmall.com

Address: A1208, Overseas Decoration Building, #122 Zhenhua RD., Futian, Shenzhen, China



LOC		DIST		REVISIONS			
P	LTR	DESCRIPTION	DATE	DMN	APVD		
R3		REVISED PER ECO-12-020973	05DEC12	KH	AS		

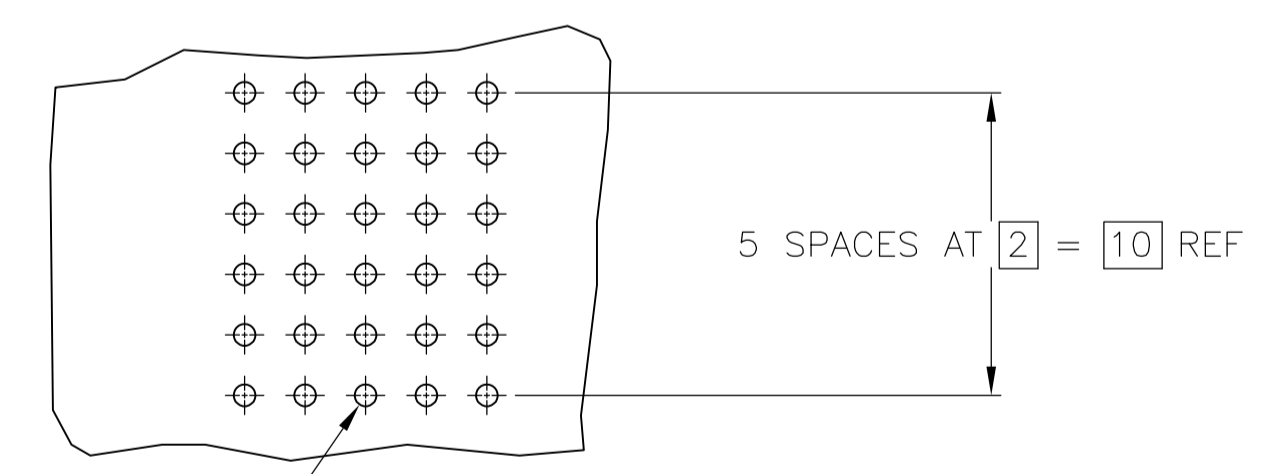
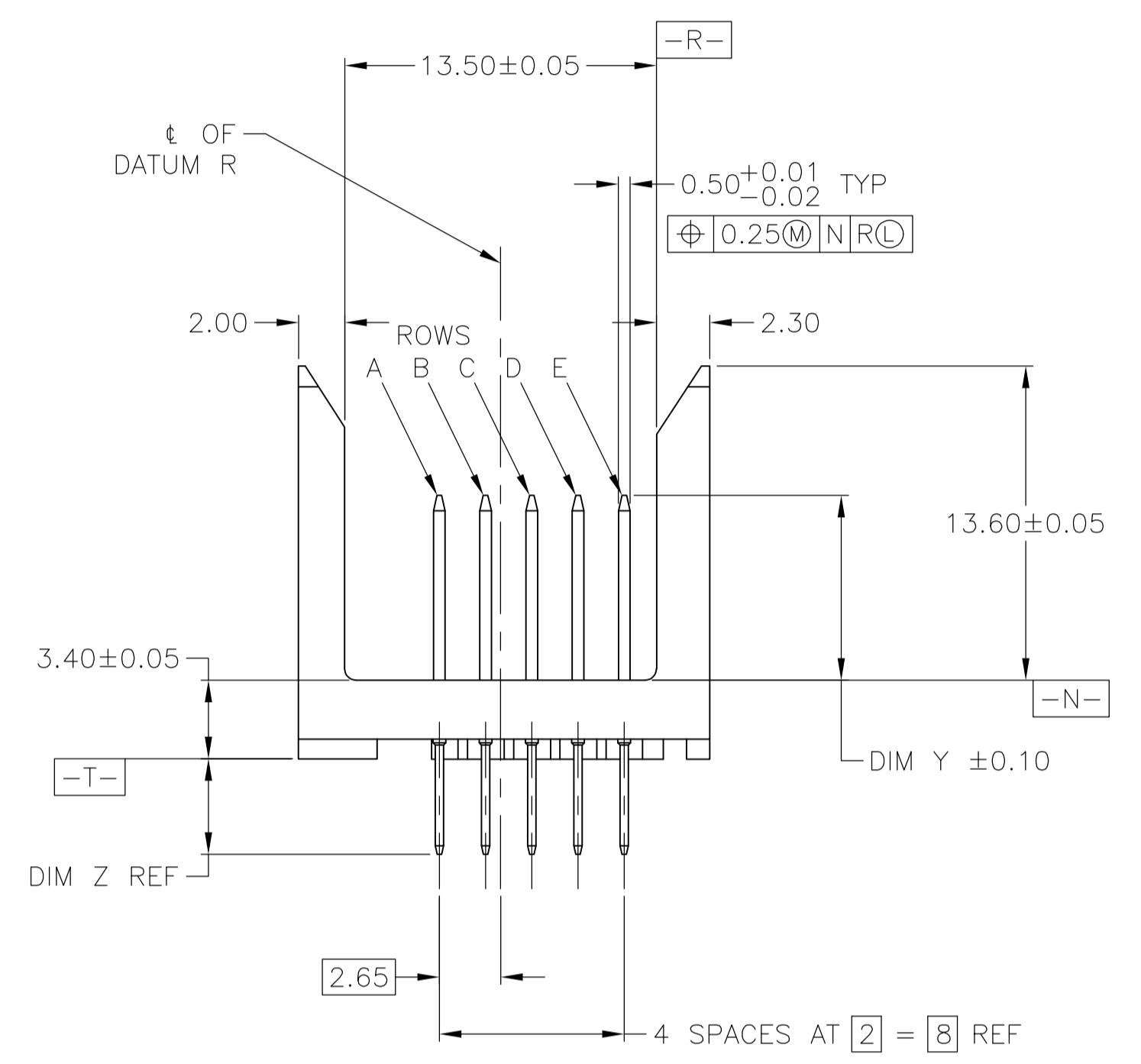
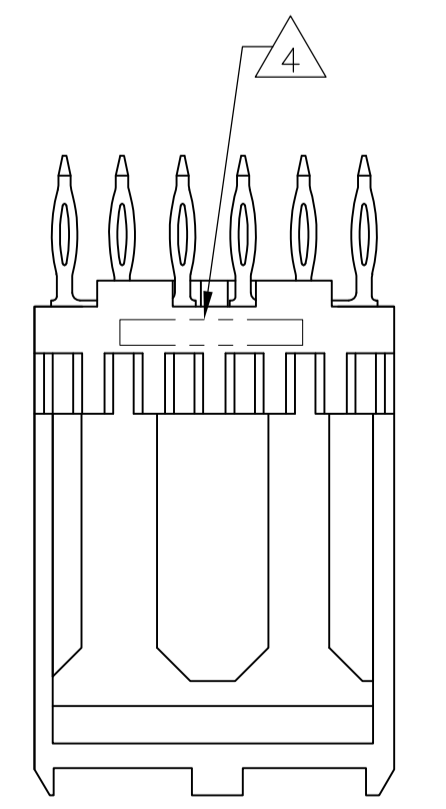
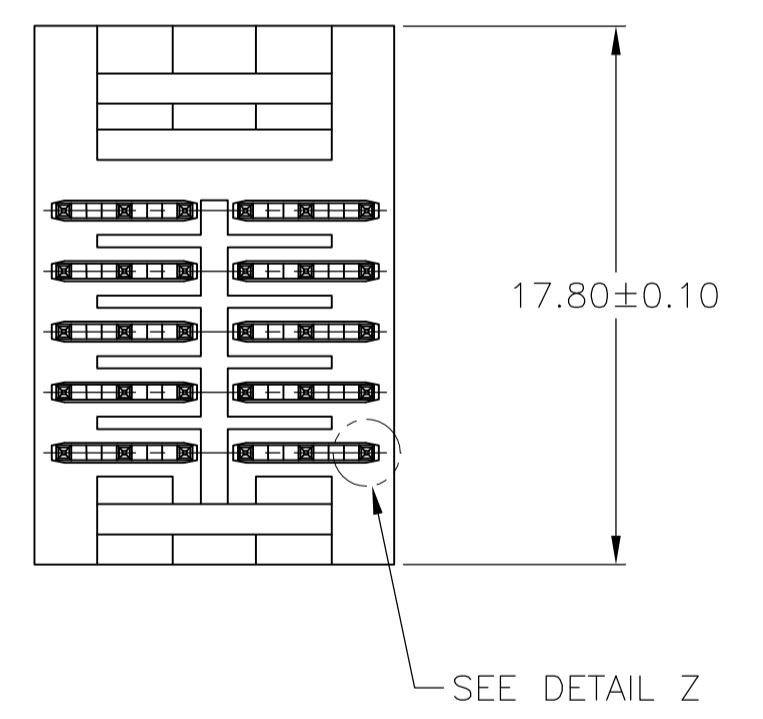
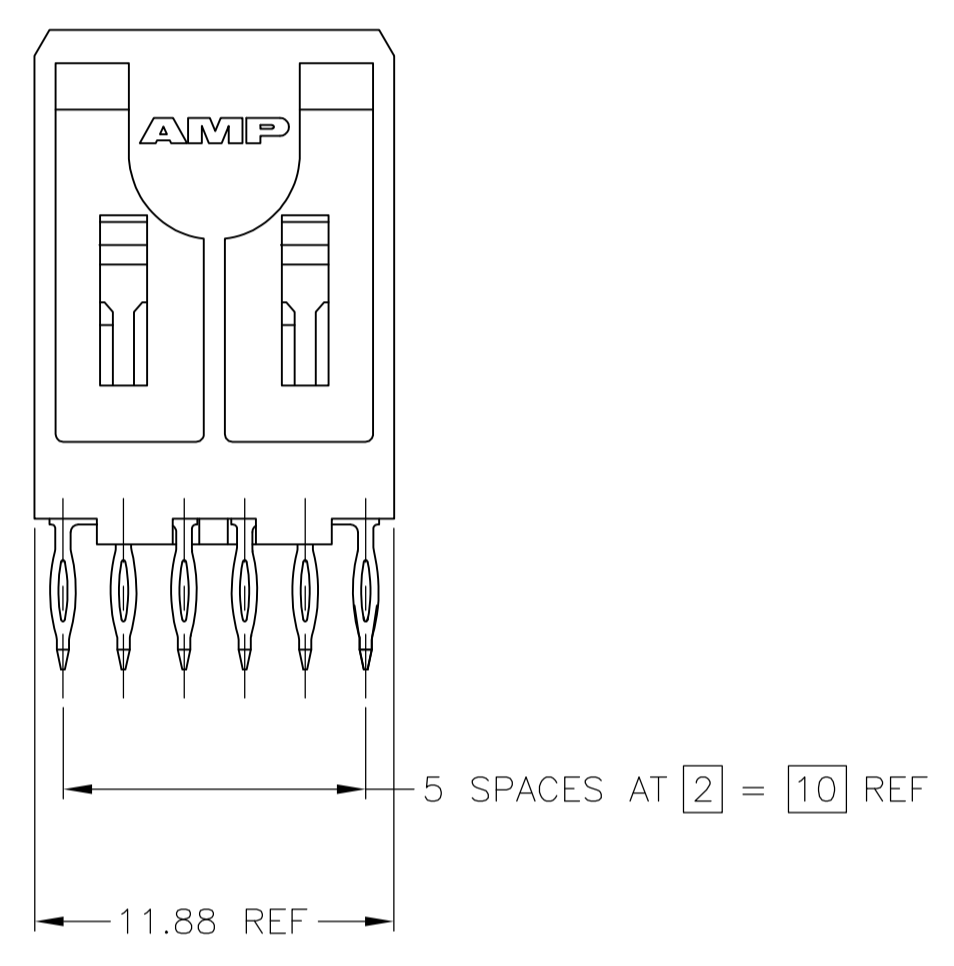
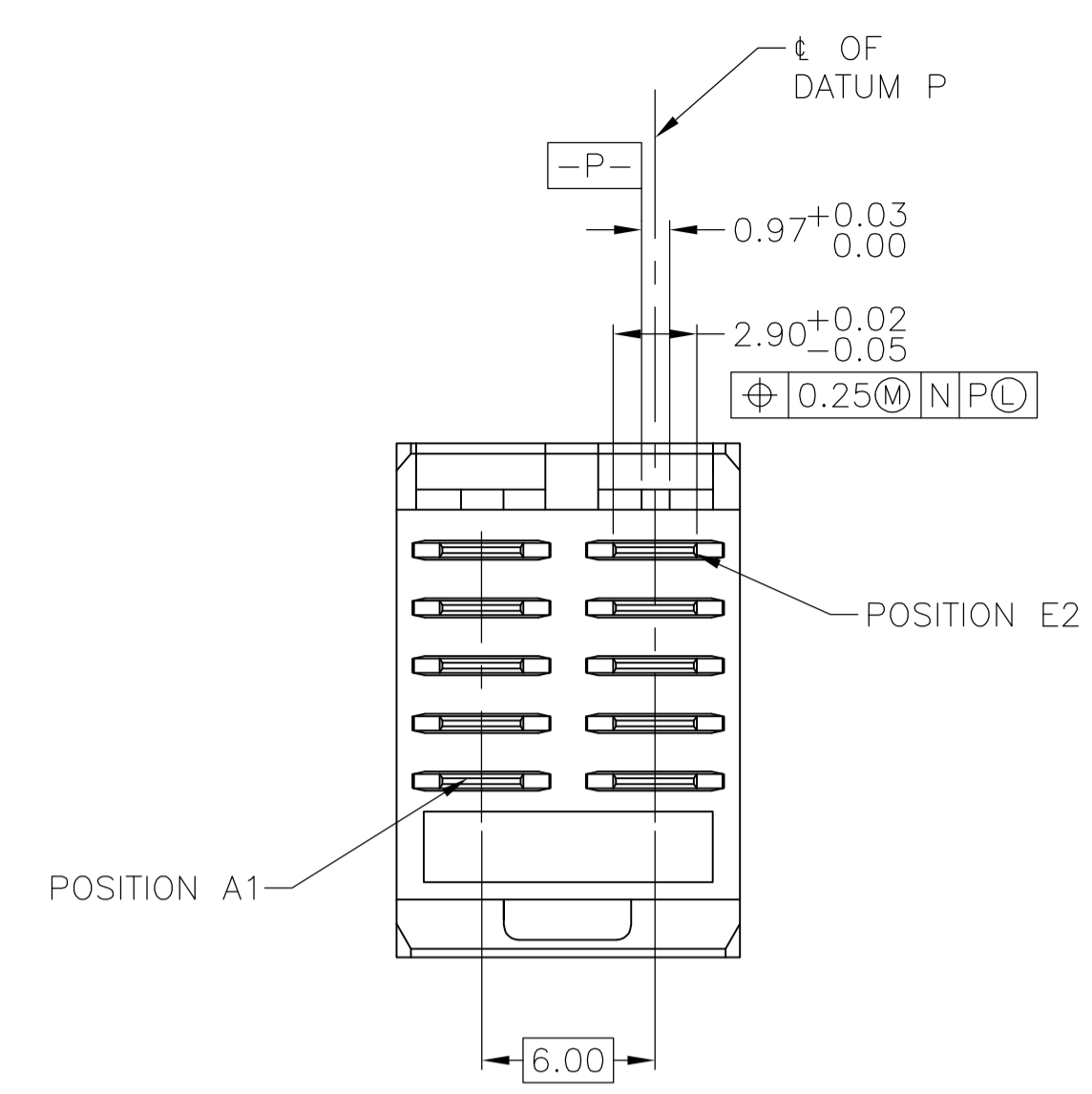

$\phi 0.725 \pm 0.075$
 PLATED THROUGH HOLE
 30 PLC
 $\phi 0.15 \text{ (M)}$

RECOMMENDED CIRCUIT PATTERN
 PER IPC-D300 TYPE II, CLASS C
 (COMPONENT SIDE)

- $\triangle 1$ HOUSING MATERIAL: LIQUID CRYSTAL POLYMER, NATURAL.
- $\triangle 2$ CONTACT MATERIAL: COPPER ALLOY.
- $\triangle 3$ CONTACT FINISH:
 UNDERPLATE (ENTIRE CONTACT):
 0.00127 MIN NICKEL PER SAE-AMS-QQ-N-290
 ON MATING SURFACES:
 FLASH GOLD PER ASTM B 488, OVER
 0.00076 MIN PALLADIUM-NICKEL OVER UNDERPLATE, OR
 0.00076 MIN GOLD PER ASTM B 488 OVER UNDERPLATE.
 ON LEADS:
 0.00127 MIN TIN-LEAD OVER UNDERPLATE.
 LUBRICATION (MIN MATING SURFACES):
 SURFACE CONDITIONER AFTER PLATING.
- $\triangle 4$ PART NUMBER AND DATE CODE IN APPROXIMATE AREA AS SHOWN.
- $\triangle 5$ OBSOLETE PARTS: OBSOLETE CIS STREAMLINING PER D.RENAUD/D.SINISI

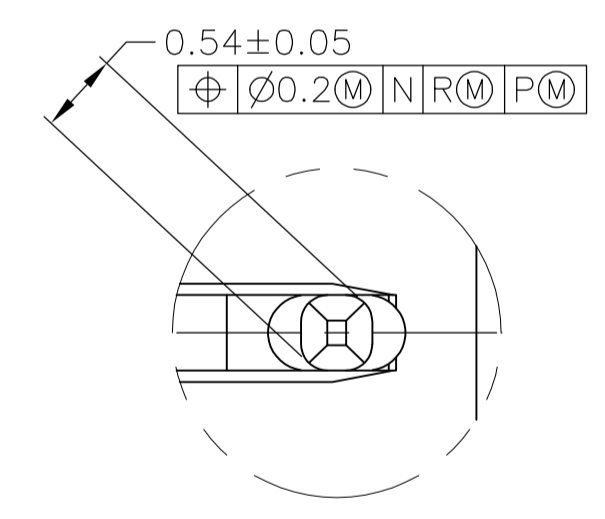

DETAIL Z
 SCALE 20:1

THIS DRAWING IS A CONTROLLED DOCUMENT.		DIN	T. SHUEY	1-7-98	TE Connectivity
DIMENSIONS: mm		CHK	W. MILLHIMES	1-16-98	
TOLERANCES UNLESS OTHERWISE SPECIFIED:		APVD	W. MILLHIMES	1-16-98	NAME
0. PLC	± -	PRODUCT SPEC		108-1441	ASSEMBLY, PIN, VERTICAL, 5 ROW, POWER MODULE, PRESS FIT
1. PLC	± -	APPLICATION SPEC		114-1075	LEAD, Z-PACK 2mm FB
2. PLC	± -	SIZE	CAGE CODE	DRAWING NO	RESTRICTED TO
3. PLC	± -	A1	00779	536642	
4. PLC	± -	WEIGHT			
ANGLES	± -	CUSTOMER DRAWING		SCALE	4:1
		SHEET		1	OF 2
		REV			R3

AD	5.00	4.25
AC	8.00	4.25
AB	7.25	4.25
AA	6.50	4.25
CONTACT LETTER	DIM Z	DIM Z

E	AA	AA	E	536642-1
D	AA	AA	D	
C	AA	AA	C	
B	AA	AA	B	
A	AA	AA	A	
ROW	1	2	ROW	PART NUMBER

CONTACT LOAD CHART

E	AA	AA	E	536642-5
D	AA	AA	D	
C	AA	AA	C	
B	AC	AC	B	
A	AA	AA	A	
ROW	1	2	ROW	PART NUMBER

CONTACT LOAD CHART

E	AB	AB	E	1-536642-6
D	AB	AB	D	
C	AB	AB	C	
B	AC	AC	B	
A	AC	AC	A	
ROW	1	2	ROW	PART NUMBER

OBSOLETE 5

CONTACT LOAD CHART

SUPERSEDED BY 536642-4

E	AA	AA	E	536642-2
D	AA	AA	D	
C	AB	AB	C	
B	AC	AC	B	
A	AC	AC	A	
ROW	1	2	ROW	PART NUMBER

CONTACT LOAD CHART

E	AA	AC	E	536642-6
D	AA	AC	D	
C	AA	AC	C	
B	AA	AC	B	
A	AA	AC	A	
ROW	1	2	ROW	PART NUMBER

CONTACT LOAD CHART

E	AB	AB	E	2-536642-4
D	AA	AA	D	
C	AB	AB	C	
B	AA	AA	B	
A	AB	AB	A	
ROW	1	2	ROW	PART NUMBER

CONTACT LOAD CHART

E			E	536642-3
D	AC	AC	D	
C	AB	AB	C	
B	AA	AA	B	
A	AC	AC	A	
ROW	1	2	ROW	PART NUMBER

OBSOLETE

CONTACT LOAD CHART

E	AC	AC	E	536642-7
D	AC	AC	D	
C	AC	AC	C	
B	AC	AC	B	
A	AC	AC	A	
ROW	1	2	ROW	PART NUMBER

OBSOLETE 5

CONTACT LOAD CHART

E	AC	AA	E	2-536642-5
D	AC	AA	D	
C	AC	AA	C	
B	AC	AA	B	
A	AC	AA	A	
ROW	1	2	ROW	PART NUMBER

OBSOLETE 5

CONTACT LOAD CHART

E	AA	AA	E	536642-4
D	AA	AA	D	
C	AB	AB	C	
B	AC	AC	B	
A	AC	AC	A	
ROW	1	2	ROW	PART NUMBER

CONTACT LOAD CHART



E	AC	AC	E	1-536642-0
D	AB	AB	D	
C	AD	AD	C	
B			B	
A	AC		A	
ROW	1	2	ROW	PART NUMBER

OBSOLETE 5

CONTACT LOAD CHART

E	AA	AA	E	2-536642-6
D	AB	AB	D	
C	AC	AC	C	
B			B	
A	AB	AC	A	
ROW	1	2	ROW	PART NUMBER

CONTACT LOAD CHART

THIS DRAWING IS A CONTROLLED DOCUMENT.		DIN T. SHUEY 1-7-98	 TE Connectivity
DIMENSIONS: mm		CHK W. MILLHIMES 1-16-98	
TOLERANCES UNLESS OTHERWISE SPECIFIED:		APVD W. MILLHIMES 1-16-98	NAME
0. PLC ± - 1. PLC ± - 2. PLC ± - 3. PLC ± - 4. PLC ± - ANGLES ± -		PRODUCT SPEC 108-1441	ASSEMBLY, PIN, VERTICAL, 5 ROW, POWER MODULE, PRESS FIT LEAD, Z-PACK 2mm FB
MATERIAL		SIZE 114-1075	RESTRICTED TO
FINISH		WEIGHT -	SCALE 4:1
		CUSTOMER DRAWING	SHEET 2 OF 2
		DRAWING NO 00779	REV R3
		DRAWING NO 536642	