



Chipsmall Limited consists of a professional team with an average of over 10 year of expertise in the distribution of electronic components. Based in Hongkong, we have already established firm and mutual-benefit business relationships with customers from,Europe,America and south Asia,supplying obsolete and hard-to-find components to meet their specific needs.

With the principle of “Quality Parts,Customers Priority,Honest Operation,and Considerate Service”,our business mainly focus on the distribution of electronic components. Line cards we deal with include Microchip,ALPS,ROHM,Xilinx,Pulse,ON,Everlight and Freescale. Main products comprise IC,Modules,Potentiometer,IC Socket,Relay,Connector.Our parts cover such applications as commercial,industrial, and automotives areas.

We are looking forward to setting up business relationship with you and hope to provide you with the best service and solution. Let us make a better world for our industry!



## Contact us

Tel: +86-755-8981 8866 Fax: +86-755-8427 6832

Email & Skype: info@chipsmall.com Web: www.chipsmall.com

Address: A1208, Overseas Decoration Building, #122 Zhenhua RD., Futian, Shenzhen, China



LOC		DIST		REVISIONS			
P	LTR	DESCRIPTION	DATE	DWN	APVD		
J1		REVISED PER ECO-08-009182	22APR08	DH	AS		

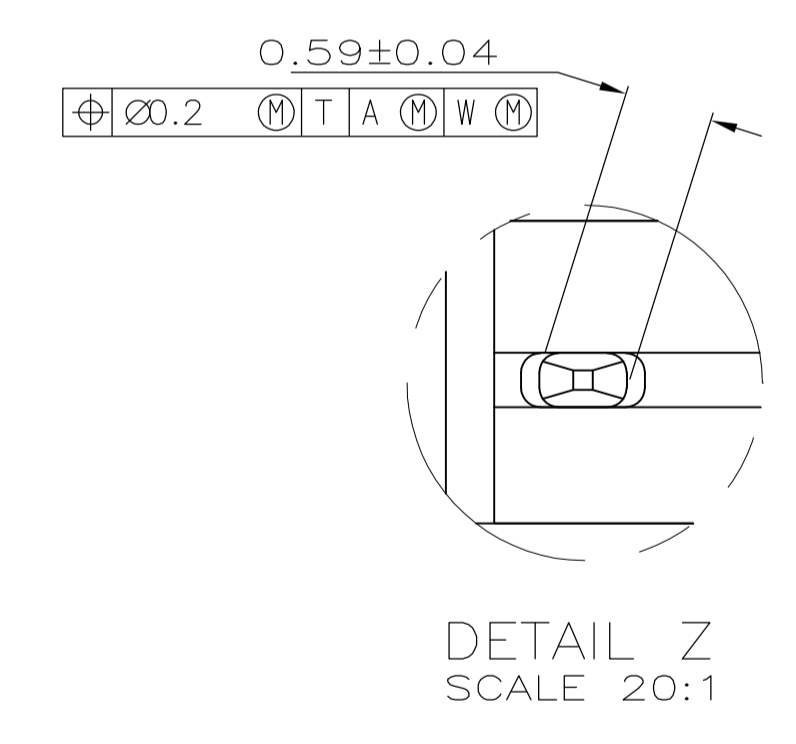
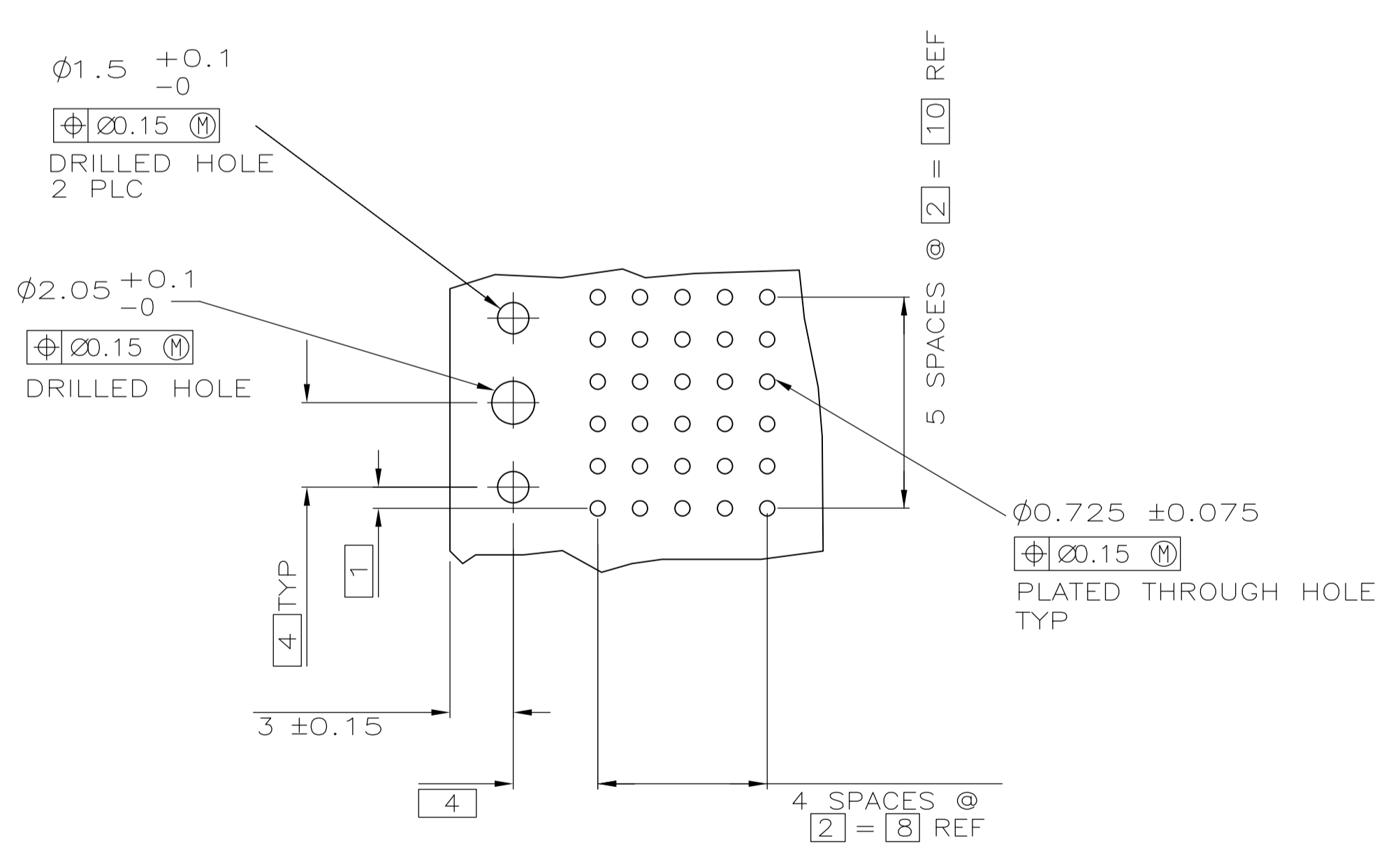
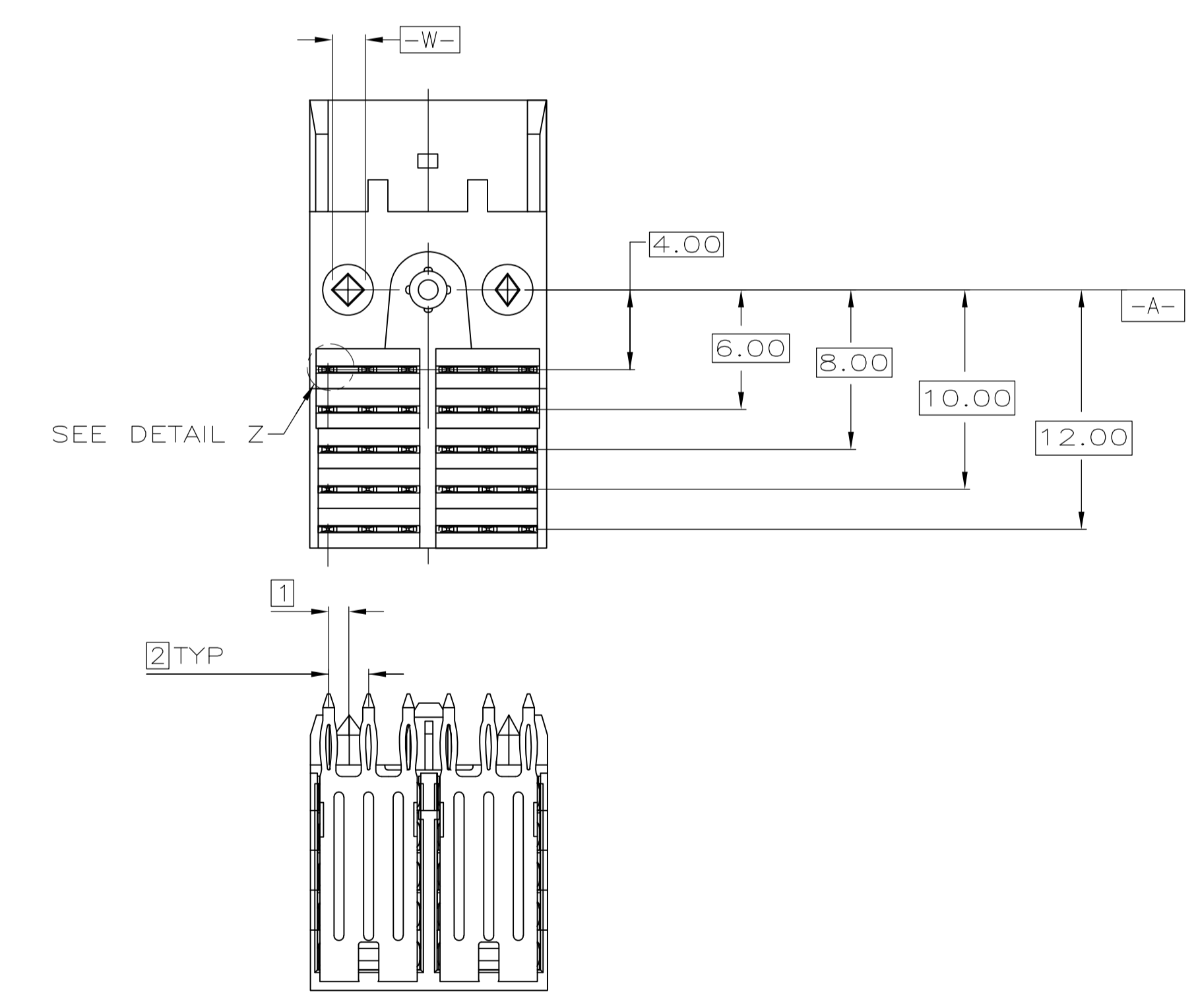
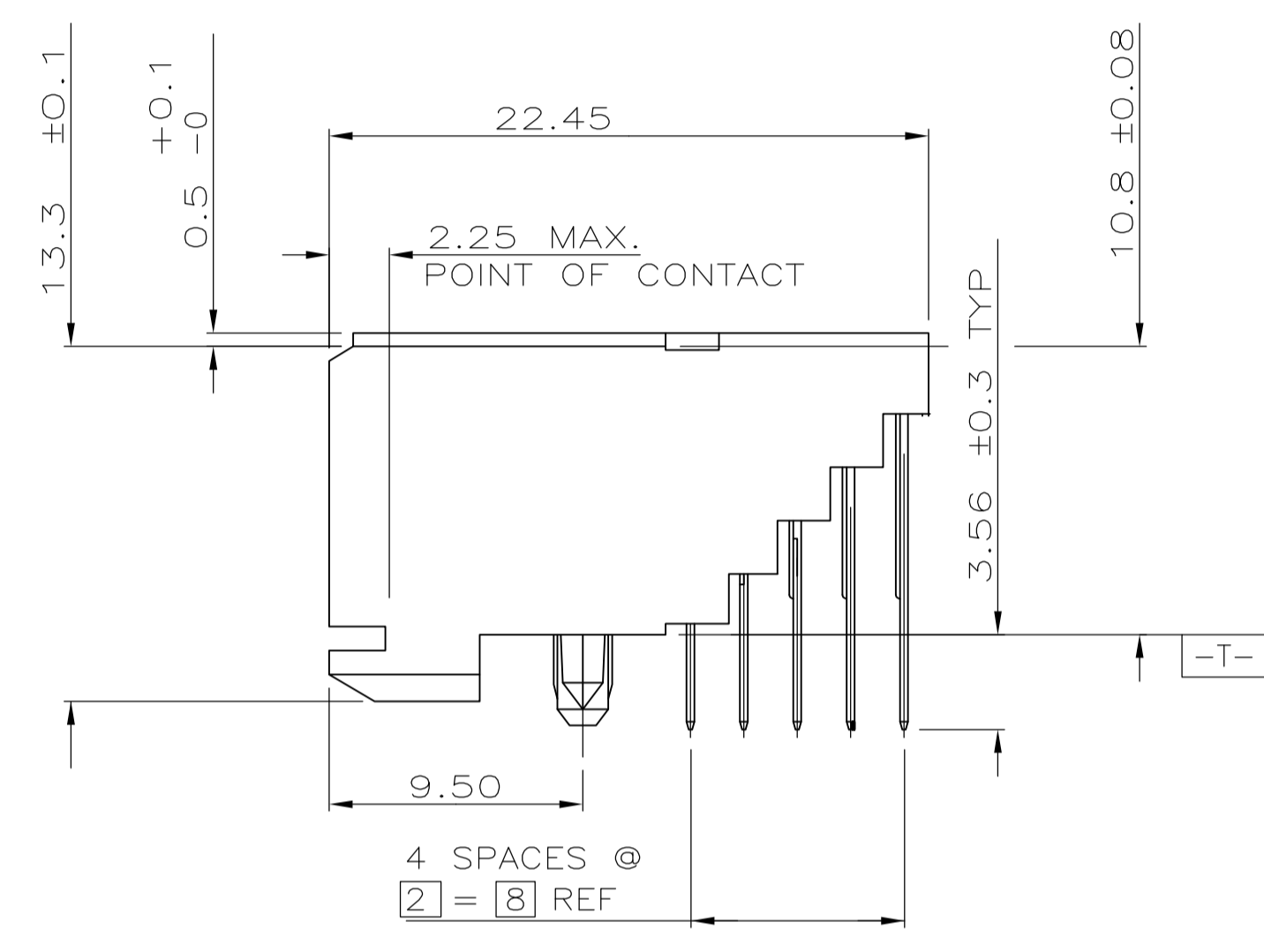
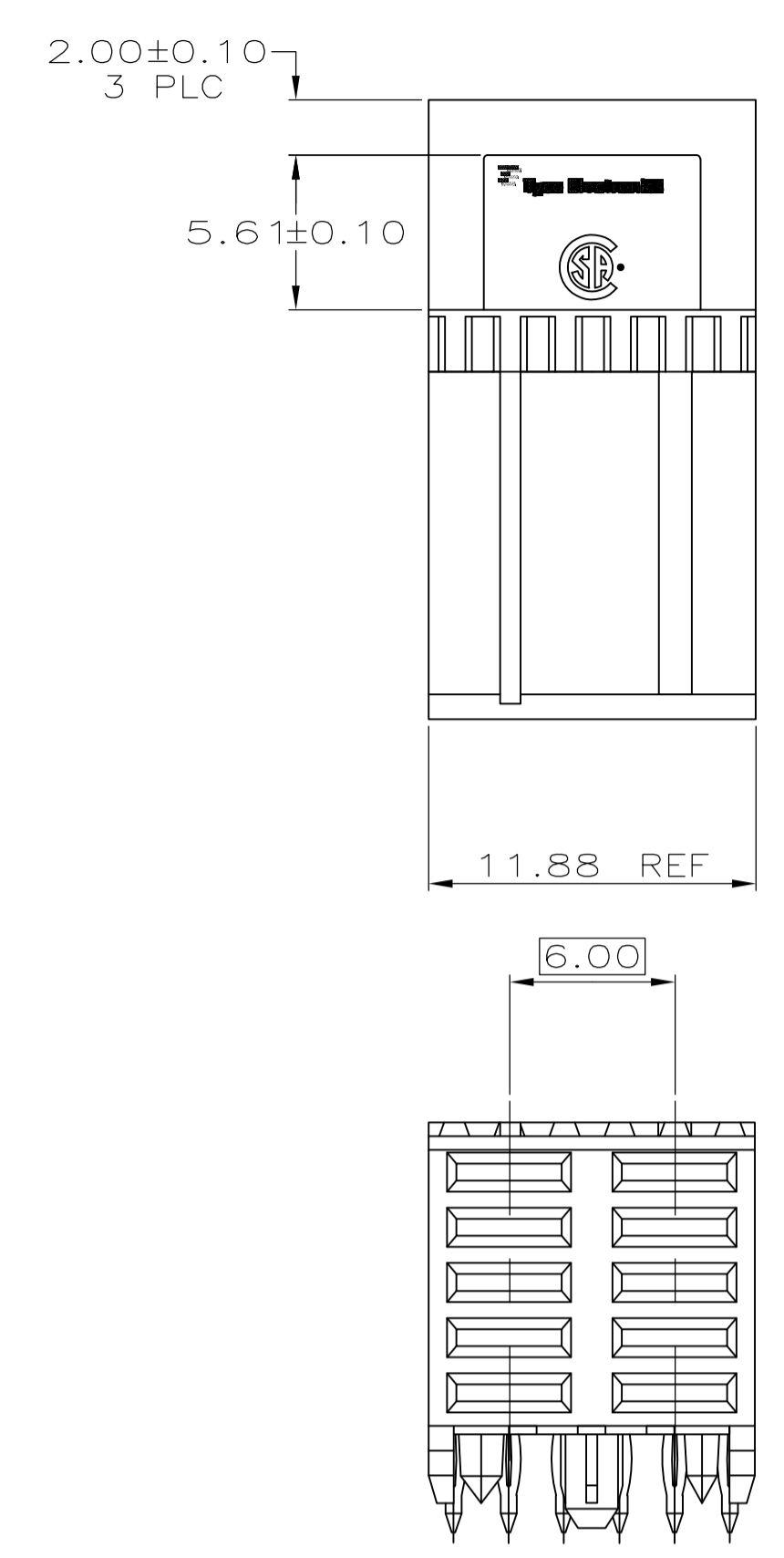

- 1 HOUSINGS MATERIAL: LIQUID CRYSTAL POLYMER.
- 2 CONTACT MATERIAL: COPPER ALLOY
- 3 CONTACT FINISH:  
 UNDERPLATE (ENTIRE CONTACT):  
 0.00127 MIN NICKEL PER SAE-AMS-QQ-N-290  
 ON MATING SURFACES:  
 FLASH GOLD PER ASTM B 488, OVER  
 0.00076 MIN PALLADIUM-NICKEL OVER UNDERPLATE, OR  
 0.00076 MIN GOLD PER ASTM B 488 OVER UNDERPLATE.  
 ON LEADS:  
 0.00127 MIN TIN-LEAD OVER UNDERPLATE.  
 LUBRICATION (MIN MATING SURFACES):  
 SURFACE CONDITIONER AFTER PLATING.

RECOMMENDED CIRCUIT PATTERN  
 PER IPC-D300 TYPE II, CLASS C  
 (COMPONENT SIDE)

FINISH	10	536649-1
	NO OF POSN	PART NUMBER

THIS DRAWING IS A CONTROLLED DOCUMENT.		DIN T. SHUEY 2-18-98	Tyco Electronics Corporation Harrisburg, PA 17105-3608	
DIMENSIONS: mm		CHK W. MILLHIMES 3-5-98	NAME ASSEMBLY, RECEPTACLE, 5 ROW, POWER MODULE, PRESS FIT LEAD, 3.56mm LEAD LENGTH, Z-PACK 2mm FB	
TOLERANCES UNLESS OTHERWISE SPECIFIED:		APVD W. MILLHIMES 3-5-98	APPLICATION SPEC	
0 PLC ± -		SIZE A1		
1 PLC ± -		CAGE CODE 00779		
2 PLC ± 0.13 [0.005]		DRAWING NO 536649		
3 PLC ± 0.013		RESTRICTED TO		
4 PLC ± -		CUSTOMER DRAWING		
ANGLES ± -		SCALE 4:1 SHEET 1 OF 1 REV J1		