



Chipsmall Limited consists of a professional team with an average of over 10 year of expertise in the distribution of electronic components. Based in Hongkong, we have already established firm and mutual-benefit business relationships with customers from,Europe,America and south Asia,supplying obsolete and hard-to-find components to meet their specific needs.

With the principle of “Quality Parts,Customers Priority,Honest Operation,and Considerate Service”,our business mainly focus on the distribution of electronic components. Line cards we deal with include Microchip,ALPS,ROHM,Xilinx,Pulse,ON,Everlight and Freescale. Main products comprise IC,Modules,Potentiometer,IC Socket,Relay,Connector.Our parts cover such applications as commercial,industrial, and automotives areas.

We are looking forward to setting up business relationship with you and hope to provide you with the best service and solution. Let us make a better world for our industry!



Contact us

Tel: +86-755-8981 8866 Fax: +86-755-8427 6832

Email & Skype: info@chipsmall.com Web: www.chipsmall.com

Address: A1208, Overseas Decoration Building, #122 Zhenhua RD., Futian, Shenzhen, China



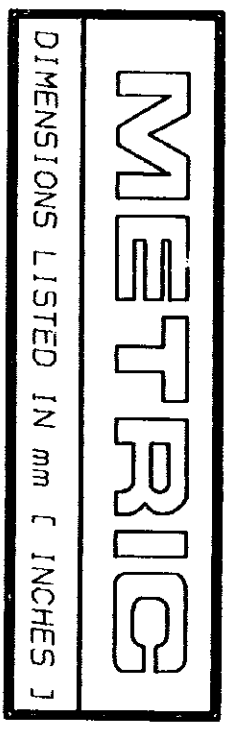

AMP WIRE RANGE	UL E13288 Listed
16-14 AWG SOLID OR STRANDED	16-14 AWG SOLID OR STRANDED
LR7189 Certified	MILITARY P/N AND CLASS
16-14 AWG SOLID OR STRANDED	NOT APPLICABLE

STAMP 85 AMP 16-14* APPROX AS SHOWN
 85 INDICATES STUD SIZE

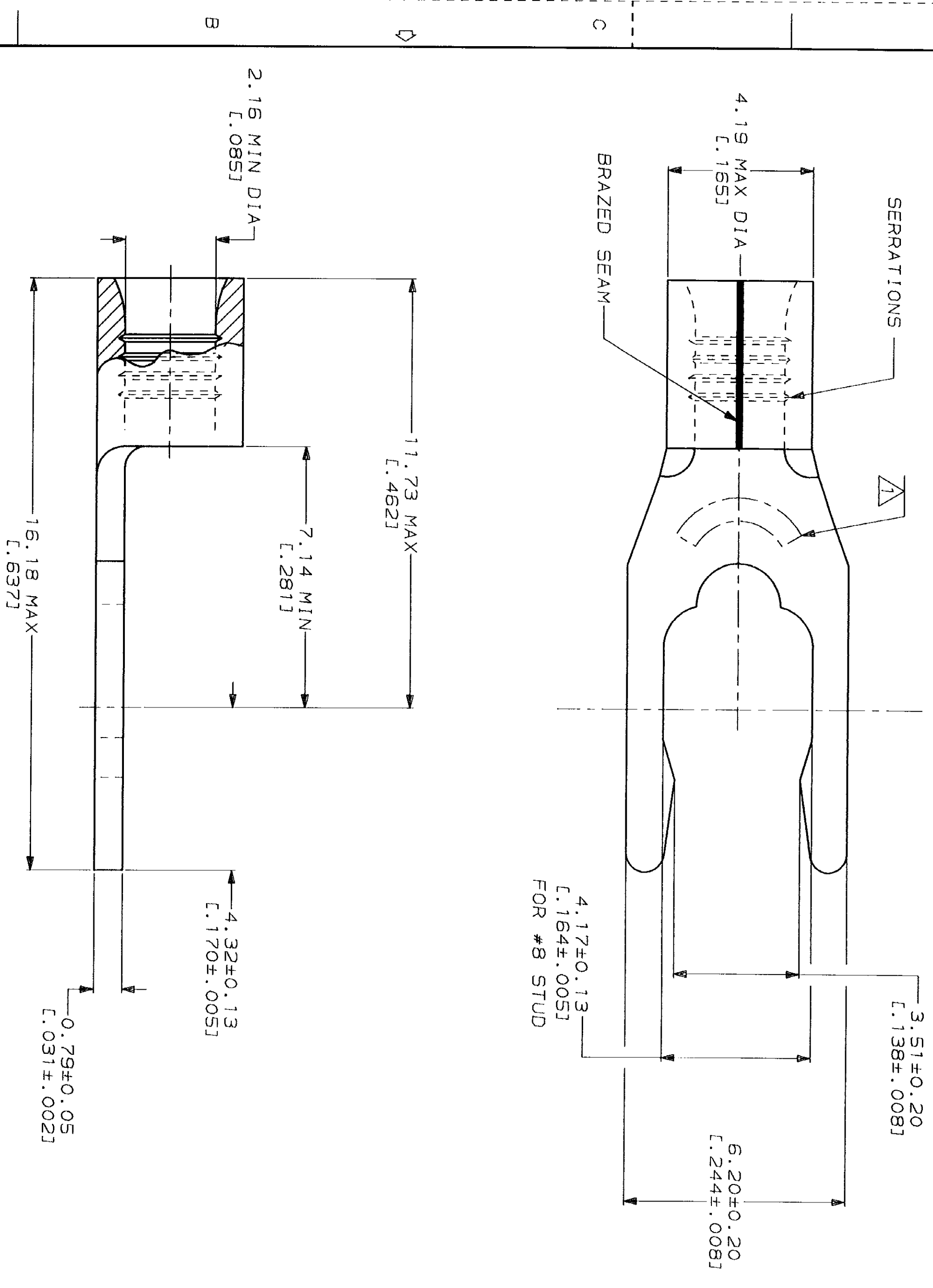

AMP INCORPORATED
CUSTOMER SERVICE SYSTEMS

FOR ADDITIONAL PRODUCT INFORMATION OR COPIES OF DRAWINGS AND TECHNICAL DOCUMENTS	PRODUCT INFORMATION CENTER 1-800-522-6752
FOR APPLICATION TOOLING INFORMATION	TOOLING ASSISTANCE CENTER 1-800-722-1111
FOR ORDER ENTRY	1-800-526-5142

MAX RECOMMENDED OPERATING
 TEMPERATURE: 170°C MAX
 VOLTAGE RATING:
 NOT APPLICABLE
 WIRE CROSS SECTIONAL AREA RANGE:
 1.04-2.62mm² [2,050-5,180] CIR MILS
 SOLID OR STRANDED

DO NOT SCALE PRINT.
 UNLESS SPECIFIED
 DIMENSIONS IN mm FINISHES
 TOLERANCES ON:
 2 PLC DEC # -
 3 PLC DEC # -
 ANGLES

DR 3-29-93
 TA BRINKMAN
 CHK 3-29-93
 DA PATTERSON
 APPD 3-29-93
 DE MILLER
 APPD 3-29-93
 JL MECKLEY
 PRODUCT SPEC

NAME
AMP
 AMP Incorporated
 Harrisburg, PA 17105-3608

TERMINAL, SHORT
 SPRING SPADE, SOLISTRAND™

FINISH
 TIN PLATE
 0.00254 [L.000100] MIN
 THK PER MIL-T-10727

APPLICATION SPEC
 WEIGHT -

SIZE CAGE CODE DRAWING NO
 SCALE 10:1
 00779
 53833

5000	ON TAPE	53833-2
---	LOOSE PIECE	53833-1
QUANTITY	PACKAGING TYPE	PART NO