



Chipsmall Limited consists of a professional team with an average of over 10 year of expertise in the distribution of electronic components. Based in Hongkong, we have already established firm and mutual-benefit business relationships with customers from,Europe,America and south Asia,supplying obsolete and hard-to-find components to meet their specific needs.

With the principle of “Quality Parts,Customers Priority,Honest Operation,and Considerate Service”,our business mainly focus on the distribution of electronic components. Line cards we deal with include Microchip,ALPS,ROHM,Xilinx,Pulse,ON,Everlight and Freescale. Main products comprise IC,Modules,Potentiometer,IC Socket,Relay,Connector.Our parts cover such applications as commercial,industrial, and automotives areas.

We are looking forward to setting up business relationship with you and hope to provide you with the best service and solution. Let us make a better world for our industry!



Contact us

Tel: +86-755-8981 8866 Fax: +86-755-8427 6832

Email & Skype: info@chipsmall.com Web: www.chipsmall.com

Address: A1208, Overseas Decoration Building, #122 Zhenhua RD., Futian, Shenzhen, China



THIS DRAWING IS UNPUBLISHED.

RELEASED FOR PUBLICATION

19

© COPYRIGHT 20 BY -

ALL RIGHTS RESERVED.

REVISIONS

P	LTR	DESCRIPTION	DATE	DWN	APVD
	A	INITIAL RELEASE	11FEB2002	MW	UR
	B	ECR-14-002026	11FEB2014	MG	GS

ERGOCRIMP DIE SET FOR USE WITH ERGOCRIMP BASIS HAND TOOL PN 539635-1.
 ERGOCRIMP DIE SET zur Verwendung mit Ergocrimp Basishandzange PN 539635-1.

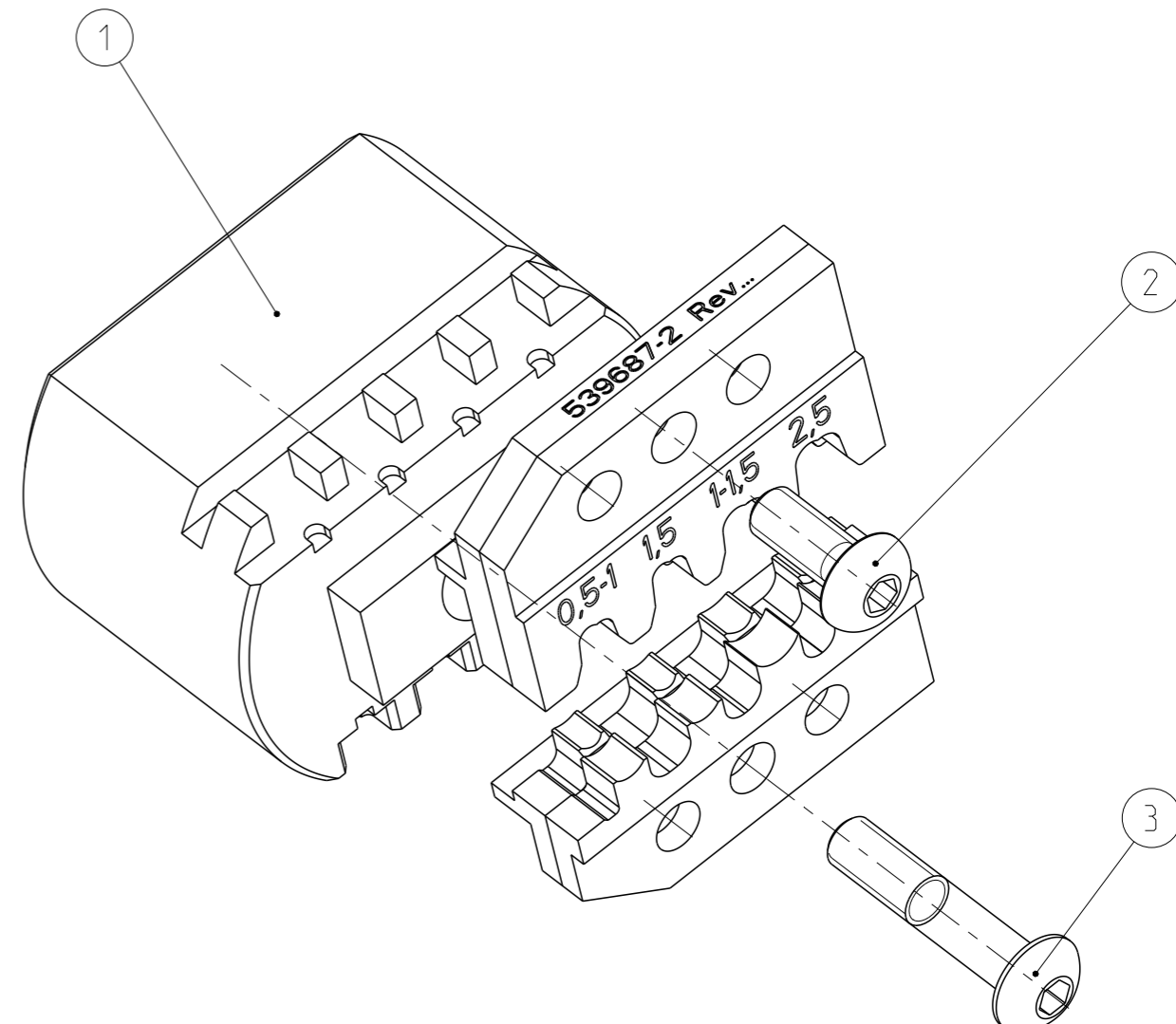

539687-2	1	411-18159	Instruction Sheet	Bedienungsanleitung	4
INCLUDED IN DELIVERY im Lieferumfang	1	1-519151-2	Screw M4x20	Schraube M4x20	3
	1	519151-9	Screw M4x10	Schraube M4x10	2
	1	9-1579025-6	Contact Locator	Kontaktpositionierer	1
	QTY Stck	PN	Description	Benennung	Pos.

Kontakt Contact	DGB (SQMM) Wire Range	Drahtcrimp/Wirecrimp		Isocrimp	Iso.-Ø	Betriebsanl. Instr. Sheet
		Höhe/Height	Breite/Width	Breite/Width	Ins. Range	
925596 / 925598 / 925622 / 925871 / 926007 / 927936 / 927973	0.5-1.0	1.35	2.28	3.05	2.0-3.0	411-18159
	1.5	1.44				
827808 / 925597 / 925613 / 925623 / 926008 / 927880 / 927937 / 1241825	1.0-1.5	1.35	2.80	4.0	2.4-3.7	
	2.5	1.70				

THIS DRAWING IS A CONTROLLED DOCUMENT.		DWN M.Goetz	11FEB2014	TE Connectivity	
DIMENSIONS: mm		CHK C.Witt	11FEB2014		
TOLERANCES UNLESS OTHERWISE SPECIFIED:		APVD C.Witt	11FEB2014	NAME ERGOCRIMP DIE SET JUNIOR AND STANDARD TIMER	
		PRODUCT SPEC		RESTRICTED TO	
MATERIAL		APPLICATION SPEC		SIZE A3	CAGE CODE
FINISH		WEIGHT 0.110 kg		DRAWING NO 539687-2	SCALE 2:1
		CUSTOMER DRAWING		SHEET 1 OF 1	REV B