



Chipsmall Limited consists of a professional team with an average of over 10 year of expertise in the distribution of electronic components. Based in Hongkong, we have already established firm and mutual-benefit business relationships with customers from,Europe,America and south Asia,supplying obsolete and hard-to-find components to meet their specific needs.

With the principle of "Quality Parts,Customers Priority,Honest Operation,and Considerate Service",our business mainly focus on the distribution of electronic components. Line cards we deal with include Microchip,ALPS,ROHM,Xilinx,Pulse,ON,Everlight and Freescale. Main products comprise IC,Modules,Potentiometer,IC Socket,Relay,Connector.Our parts cover such applications as commercial,industrial, and automotives areas.

We are looking forward to setting up business relationship with you and hope to provide you with the best service and solution. Let us make a better world for our industry!



## Contact us

Tel: +86-755-8981 8866 Fax: +86-755-8427 6832

Email & Skype: info@chipsmall.com Web: www.chipsmall.com

Address: A1208, Overseas Decoration Building, #122 Zhenhua RD., Futian, Shenzhen, China



# USB A jack 90° PCB mount

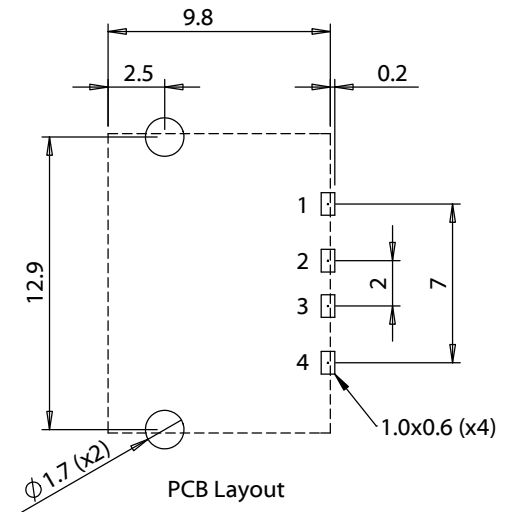
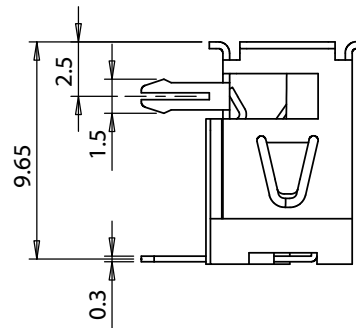
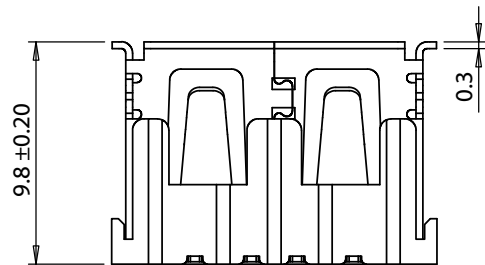
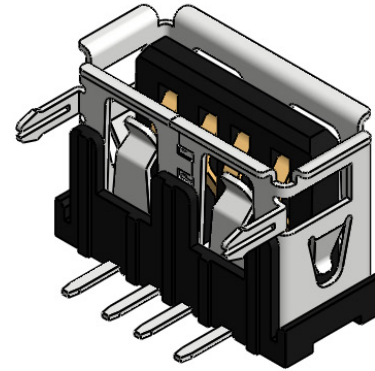
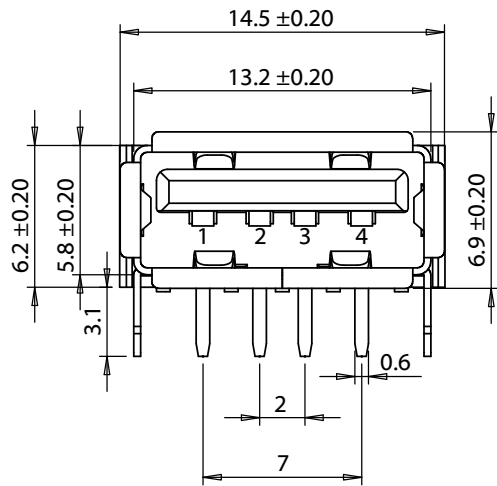

## NOTES

RoHS and REACH compliant

# TENSILITY

20802 Sockeye Place #130  
 Bend, OR 97701 USA  
 tel 541.323.3228 fax 541.323.4202  
 800 877.670.7118 www.tensility.com

DIMENSIONS ARE IN MILLIMETERS

TOLERANCES:  
 Up to 1.0: ± 0.1 mm  
 1.0 to 10.0: ± 0.2 mm  
 Over 10.0: ± 0.3 mm

## DESCRIPTION:

Connector, USB A Jack, PCB mount, 90°, nickel shell, ground terminals, black insulator

SIZE

A

PART NUMBER

54-00015

SCALE: 3:1

SHEET 1 OF 2

