



Chipsmall Limited consists of a professional team with an average of over 10 year of expertise in the distribution of electronic components. Based in Hongkong, we have already established firm and mutual-benefit business relationships with customers from,Europe,America and south Asia,supplying obsolete and hard-to-find components to meet their specific needs.

With the principle of “Quality Parts,Customers Priority,Honest Operation,and Considerate Service”,our business mainly focus on the distribution of electronic components. Line cards we deal with include Microchip,ALPS,ROHM,Xilinx,Pulse,ON,Everlight and Freescale. Main products comprise IC,Modules,Potentiometer,IC Socket,Relay,Connector.Our parts cover such applications as commercial,industrial, and automotives areas.

We are looking forward to setting up business relationship with you and hope to provide you with the best service and solution. Let us make a better world for our industry!



Contact us

Tel: +86-755-8981 8866 Fax: +86-755-8427 6832

Email & Skype: info@chipsmall.com Web: www.chipsmall.com

Address: A1208, Overseas Decoration Building, #122 Zhenhua RD., Futian, Shenzhen, China



Materials

- 1. Brass, nickel plating, 1µm minimum
- 2. Nylon PA46, black

Electrical requirements

Dielectric strength: 1 min @ 500 Vac
 Insulation resistance: 100 MΩ @ 500 Vdc
 Contact resistance: 50 mΩ or less

Mechanical requirements

Insertion force: 0.4 ~ 4 kgf
 Withdrawl force: 0.4 ~ 4 kgf
 Durability: 5000 mating cycles while maintaining insertion force of 0.3 ~ 4 kg; withdrawl force of 0.3 ~ 4 kgf; contact resistance of 60mΩ or less.

Environmental tests

Damp test: 40 °C, RH 90-100% for 96 hrs. Cool to ambient and recover for 2 hours. Maintain dielectric strength of 500 Vac for 1 min, insulation resistance of 50 MΩ @ 500 Vdc minimum.

Dry test: 70 °C, RH 70-85% for 96 hrs. Cool to ambient and recover for 2 hours. Maintain contact resistance of 100 mΩ or less with no looseness or deformation.

Salt spray test: 35 ±2 °C, RH 90-95%, 5% NaCl mist for 24 hrs. Wash parts after test. Maintain mechanical requirements and a contact resistance of less than 100 mΩ.

Operating range

-25 to 70 °C, relative humidity of 85% or less

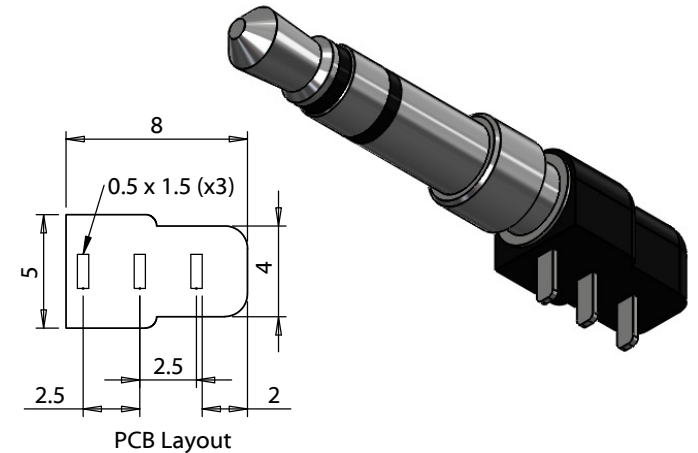
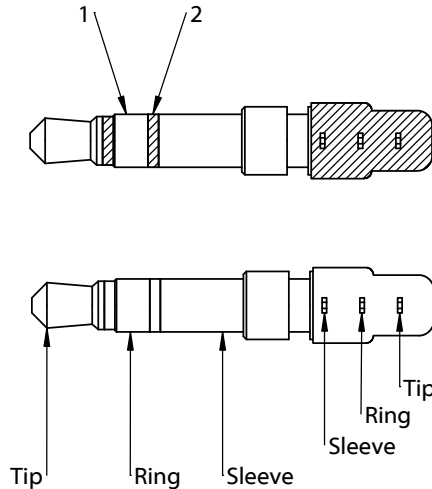
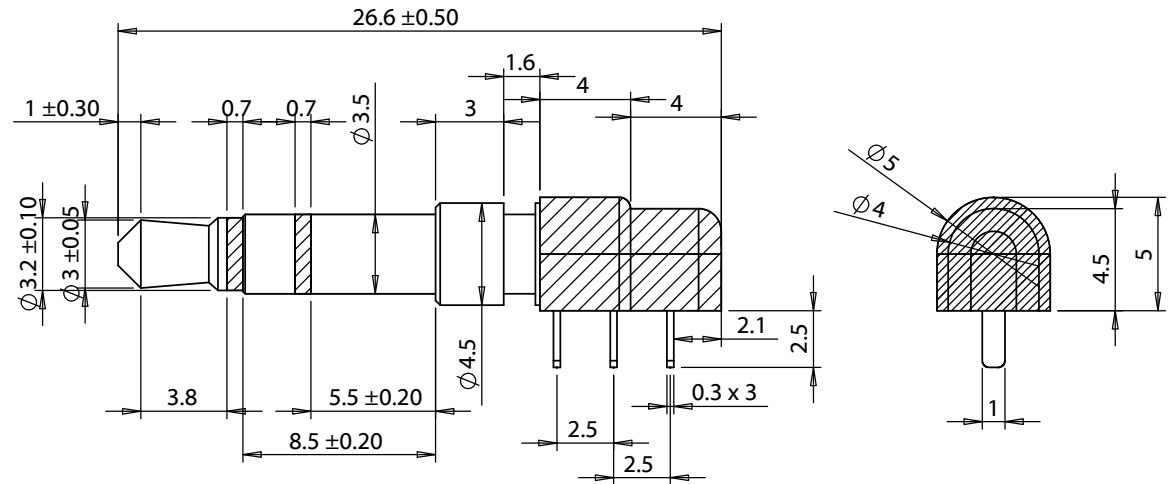

REVISION	DATE	DESCRIPTION
A	7/9/2015	Initial release
A1	10/27/2015	Added PCB dimensioning and wiring information

PREPARED:
GL 2015.10.27 15:50:15 -07'00'

VERIFIED:
AG 2015.10.27 15:51:37 -07'00'

DIMENSIONS ARE IN MILLIMETERS

TOLERANCES:
 X: ± 0.5 mm
 X.X: ± 0.3 mm
 X.XX: ± 0.05 mm

NOTES
 RoHS and REACH compliant
 Drawing in third angle projected

DESCRIPTION:
 Connector, 3C audio plug, 3.5xL26.6 mm, brass, nickel plated, PCB mount

TENSILITY

20802 Sockeye Place #130
 Bend, OR 97701 USA
 tel 541.323.3228 fax 541.323.4202
 800 877.670.7118 www.tensility.com

SIZE A	PART NUMBER 54-00036
SCALE: 5:1	WEIGHT:
SHEET 1 OF 1	