



Chipsmall Limited consists of a professional team with an average of over 10 year of expertise in the distribution of electronic components. Based in Hongkong, we have already established firm and mutual-benefit business relationships with customers from,Europe,America and south Asia,supplying obsolete and hard-to-find components to meet their specific needs.

With the principle of “Quality Parts,Customers Priority,Honest Operation,and Considerate Service”,our business mainly focus on the distribution of electronic components. Line cards we deal with include Microchip,ALPS,ROHM,Xilinx,Pulse,ON,Everlight and Freescale. Main products comprise IC,Modules,Potentiometer,IC Socket,Relay,Connector.Our parts cover such applications as commercial,industrial, and automotives areas.

We are looking forward to setting up business relationship with you and hope to provide you with the best service and solution. Let us make a better world for our industry!



## Contact us

Tel: +86-755-8981 8866 Fax: +86-755-8427 6832

Email & Skype: info@chipsmall.com Web: www.chipsmall.com

Address: A1208, Overseas Decoration Building, #122 Zhenhua RD., Futian, Shenzhen, China



| LOC | DIST | REVISIONS   |                             |           |        |
|-----|------|-------------|-----------------------------|-----------|--------|
| P   | LTR  | DESCRIPTION | DATE                        | DWN       | APVD   |
| AJ  | 16   | A           | REVISED PER EC 0514-0150-05 | 06OCT2005 | REH JL |

- ① CARBON STEEL PER ASTM-A-108
- ② BRASS PER ASTM-B-16
- ③ PHOSPHOR BRONZE PER ASTM-B-139
- ④ POLYMETHYLPENTENE: GENERAL PURPOSE
- ⑤ SILICONE RUBBER PER ZZ-R-765
- ⑥ ZINC DIE CAST PER ASTM-B-86
- ⑦ GOLD PLATE PER ASTM-B-488, 0.76µm [.000030] MIN THICKNESS
- ⑧ NICKEL PLATE PER QQ-N-290, 1.27µm [.000050] MIN THICKNESS
- ⑨ NICKEL PLATE PER QQ-N-290, 2.54µm [.000100] MIN THICKNESS

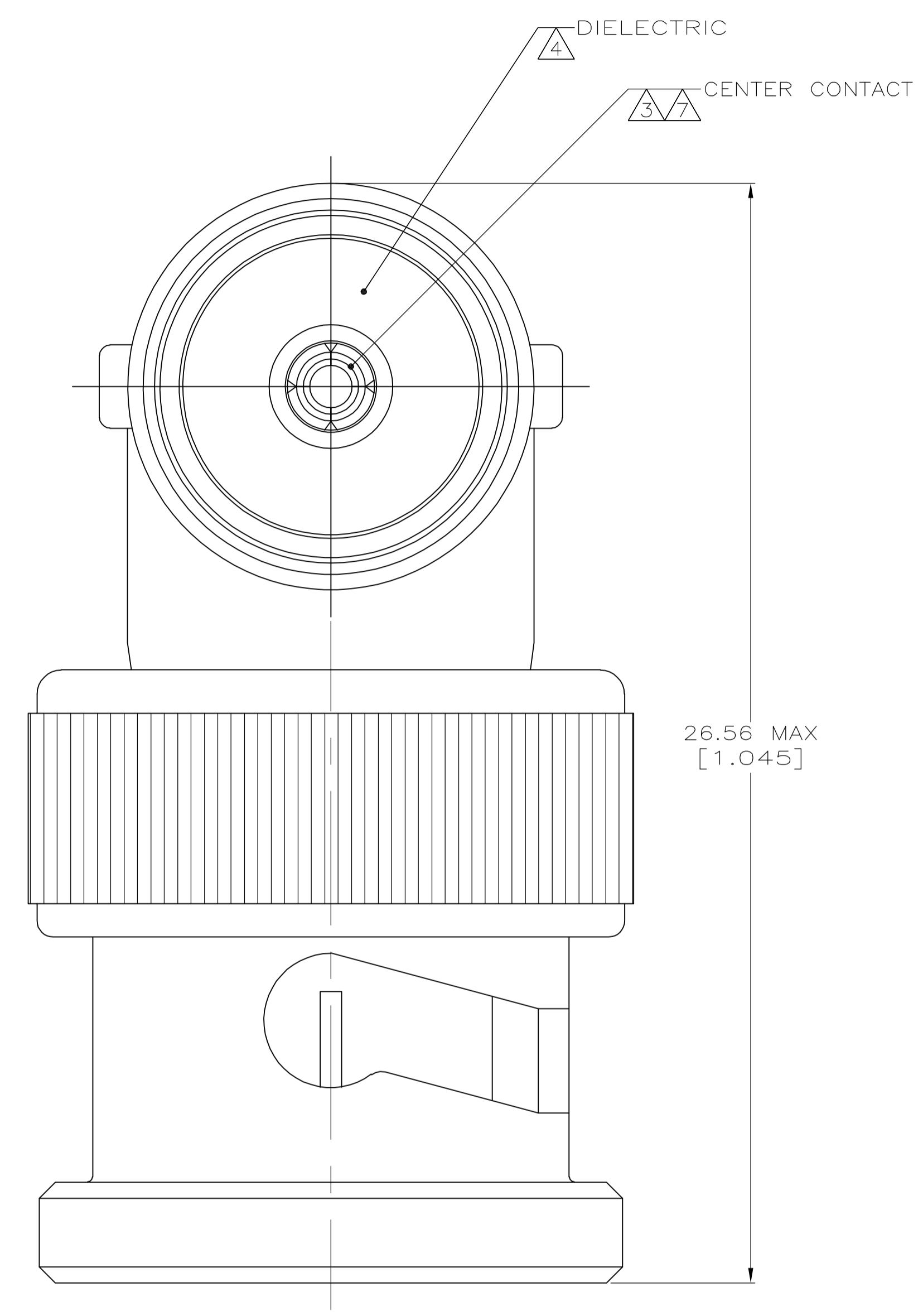
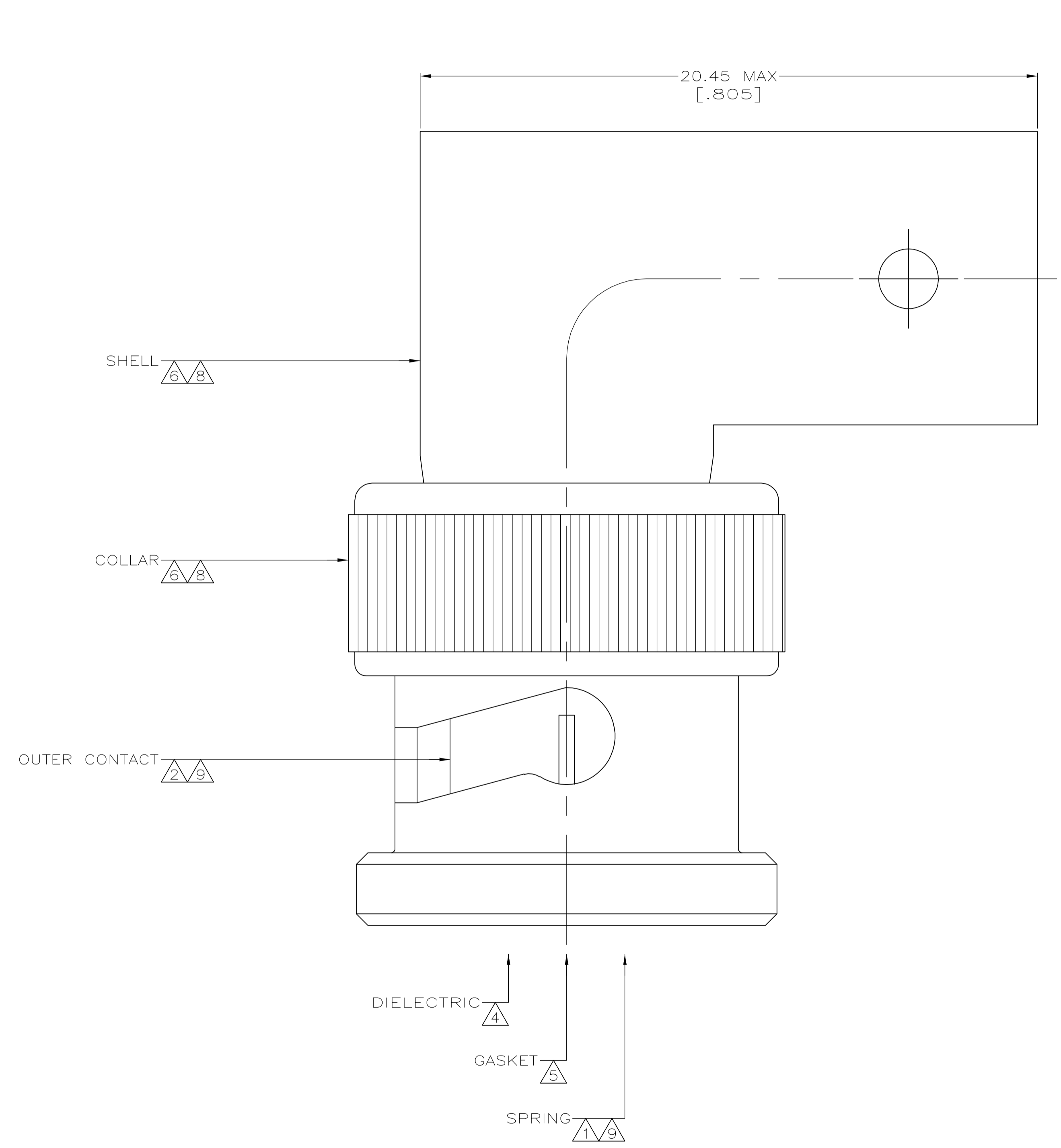

5415020-1  
 PART NUMBER

|  |  |  |   |  |
|--|--|--|---|--|
| THIS DRAWING IS A CONTROLLED DOCUMENT. |  | DWN<br>L. VARELA - 18APR2005                           | Tyco Electronics Corporation<br>Harrisburg, PA 17105-3608 |  |
| DIMENSIONS:<br>mm [INCHES]             |  | CHK<br>J. HAVENER<br>18APR2005                         | APVD<br>J. LIPPERT<br>18APR2005                           |  |
| TOLERANCES UNLESS OTHERWISE SPECIFIED: |  | NAME<br>PLUG-JACK ADAPTER,<br>RIGHT ANGLE, 75 OHM, BNC |   |  |
| 0 PLC ± -                              |  | PRODUCT SPEC<br>108-12096                              |   |  |
| 1 PLC ± -                              |  | APPLICATION SPEC                                       |   |  |
| 2 PLC ± -                              |  | SIZE<br>A1   |   |  |
| 3 PLC ± -                              |  | CAGE CODE<br>00779                                     |   |  |
| 4 PLC ± -                              |  | DRAWING NO<br>5415020                                  |   |  |
| ANGLES ± -                             |  | RESTRICTED TO  |   |  |
| FINISH SEE NOTES                       |  | WEIGHT<br>-  |   |  |
| MATERIAL SEE NOTES                     |  | CUSTOMER DRAWING                                       |   |  |
|  |  | SCALE 10:1 SHEET 1 of 1 REV A                          |   |  |