



Chipsmall Limited consists of a professional team with an average of over 10 year of expertise in the distribution of electronic components. Based in Hongkong, we have already established firm and mutual-benefit business relationships with customers from,Europe,America and south Asia,supplying obsolete and hard-to-find components to meet their specific needs.

With the principle of “Quality Parts,Customers Priority,Honest Operation,and Considerate Service”,our business mainly focus on the distribution of electronic components. Line cards we deal with include Microchip,ALPS,ROHM,Xilinx,Pulse,ON,Everlight and Freescale. Main products comprise IC,Modules,Potentiometer,IC Socket,Relay,Connector.Our parts cover such applications as commercial,industrial, and automotives areas.

We are looking forward to setting up business relationship with you and hope to provide you with the best service and solution. Let us make a better world for our industry!



Contact us

Tel: +86-755-8981 8866 Fax: +86-755-8427 6832

Email & Skype: info@chipsmall.com Web: www.chipsmall.com

Address: A1208, Overseas Decoration Building, #122 Zhenhua RD., Futian, Shenzhen, China



PRODUCT NUMBER

5 4 2 0 2 - X X X X X - X X X LF

PLATING
 S=15μ" [0.38μm]
 ON CONTACT AREA
 100μ" [2.5μm] TIN
 ON TAIL (NOTE 13)
 G=30μ" [0.76μm]
 ON CONTACT AREA
 100μ" [2.5μm] TIN
 ON TAIL (NOTE 13)
 T=100μ" [2.5μm] TIN
 ON CONTACT AREA
 AND ON TAIL (SEE NOTE 11)
 F=2μ" [0.05μm] GOLD
 ON CONTACT AREA
 AND ON TAIL

LEAD STYLE	POST	TAIL OVERALL WIDTH	PCB LAYOUT
08 30	0.230/5.84 0.318/8.08	.290 ^{+0.015} / _{-0.017} / 7.37 ^{+0.38} / _{-0.43}	FIGURE 1
60	0.575/14.60	.374 ^{+0.015} / _{-0.017} / 9.50 ^{+0.38} / _{-0.43}	FIGURE 2

NOTES:

- HOUSING MAT'L: HIGH TEMPERATURE THERMOPLASTIC. FLAME RETARDANT PER UL 94V-0. COLOR: BLACK OR MINERAL FILLED LCP FLAME RETARDANT PER UL-94V-0. COLOR: BLACK. THESE PART NUMBERS WILL WITHSTAND EXPOSURE TO 260 C PEAK TEMPERATURE FOR 20 SECONDS IN WAVE SOLDER, INFRA-RED OR VAPOR PHASE SOLDER PROCESS.
- PIN MATERIAL: PHOSPHOR-BRONZE
- TO DETERMINE DIMENSIONS:
N = NUMBER OF POSITIONS ROW.
EXAMPLE: 10 POS., N x .100/2.54=1.00/25.4
- 2LBS/0.9KG MIN. PIN RETENTION IN EITHER DIRECTION.
- PACKAGING: NONE =POLY BAGS WITHOUT PICKUP CAP.
T =TUBES (OMIT DASH IF NOT POLARIZED).
P =TUBES WITH PICKUP CAPS.
A =TAPE AND REEL WITH PICKUP CAPS.
C =CUSTOMIZED TAPE AND REEL WITH PICKUP CAPS.
D =TAPE AND REEL WITHOUT PICKUP CAPS.
S =SPECIAL REQUEST OF TAPE AND REEL WITH PICKUP CAPS.
M =TAPE AND REEL WITH PICKUP CAPS FOR SPECIAL CUSTOMER.
- FOR POLARIZATION, SPECIFY POSITION NUMBER (i.e. A03=ROW A POS. 3) TO OMIT PIN. OMIT FROM PRODUCT NUMBER IF THIS FEATURE IS NOT APPLICABLE. PRODUCT MANAGEMENT APPROVAL REQUIRED PRIOR TO RELEASE OR SALE OF POLARIZED PRODUCTS.
- UNDERPLATING: 50μ" /1.2μm Ni.
- PIN TIPS ON Sn PLATED PRODUCT MAY HAVE BARE METAL ON TWO SIDES, BOTH ENDS.
- PART NUMBERS WITH "LF" SUFFIX AT THE END ARE LEAD FREE.
- THESE PRODUCTS MEETS EUROPEAN UNION DIRECTIVES AND OTHER COUNTRY REGULATION AS DESCRIBED IN GS-22-008.
- "THIS PRODUCT HAS 100% PURE TIN PLATING IN THE INTERFACE AND HAS NOT BEEN TESTED FOR WHISKER GROWTH IN ALL INTERCONNECT ENVIRONMENTS."
- THE HOUSING WILL WITHSTAND EXPOSURE TO 260°C PEAK TEMPERATURE FOR 20 SECONDS IN A CONVECTION, INFRA-RED OR VAPOR PHASE REFLOW OVEN. SEE APPLICATION NOTES/PROCEDURES IF THEY ARE AVAILABLE.
- MAY BE EITHER GOLD OR GXT PLATED AT MANUFACTURER'S OPTION

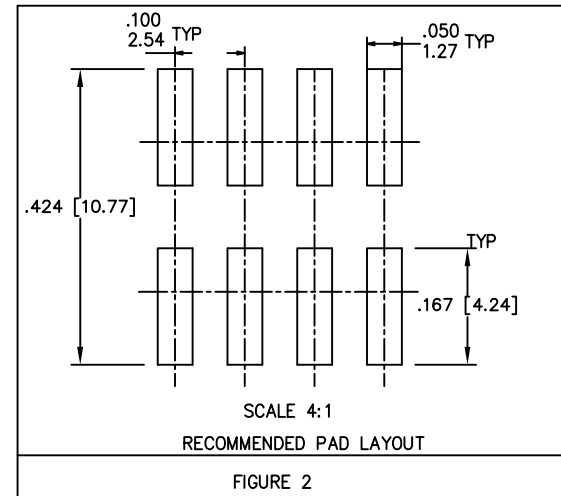
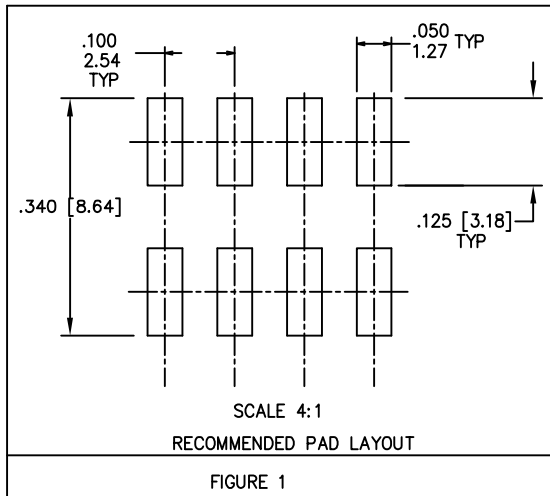

mat'l. code SEE NOTES 1&2		surface ISO 1302 ✓	tolerance ISO 406 ISO 1101	projection INCH/MM	product family BERGSTIK
ltr	ecn no dr	date	tolerances unless otherwise specified		title
W	ELX-N-12227	JZ	2012-07-15	angles .XX±01/XX±0.3	.100 UNSHROUDED HDR DUAL ROW VERT. SMT.
X	ELX-N-14748	ZK	2013-05-14	linear .XXX±006/XXX±0.13	
Y	ELX-N-19883	JH	2015-01-15	0°±2'	scale 1:1
AA	ELX-N-21232	MZ	2015-06-25	dr D.INGRAM 1999-05-17	dwg no sheet 1 of 4 size
AB	ELX-N-22858	MZ	2015-12-22	enrg H.SUNDAY 1999-07-21	54202 A3
				chr H.SUNDAY 1999-07-21	type Product Customer Drawing
				appd H.SUNDAY 1999-07-21	
sheet index	revision sheet	AB 1	AB 2	AB 3	AB 4

Copyright FCI
 FCIconnect.com

PRODUCT NUMBER
SEE SHEET 1

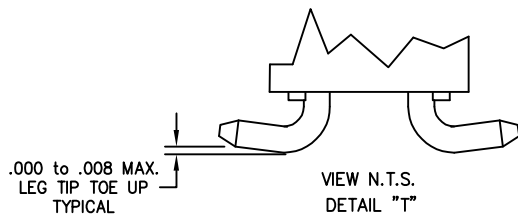
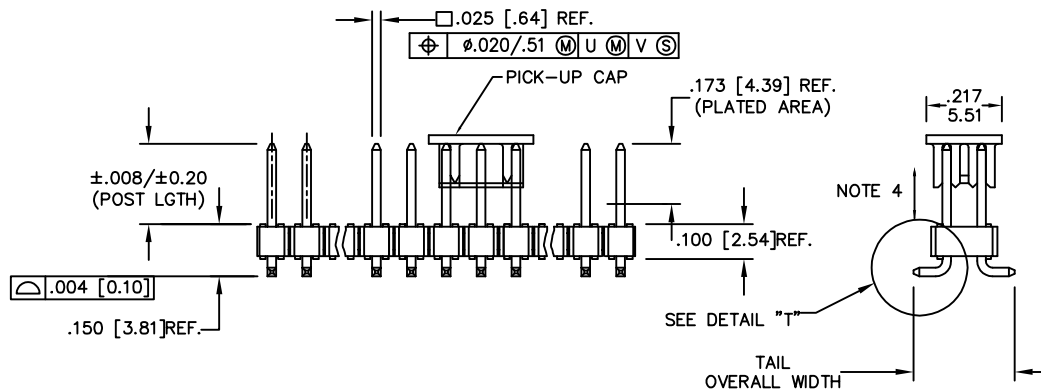
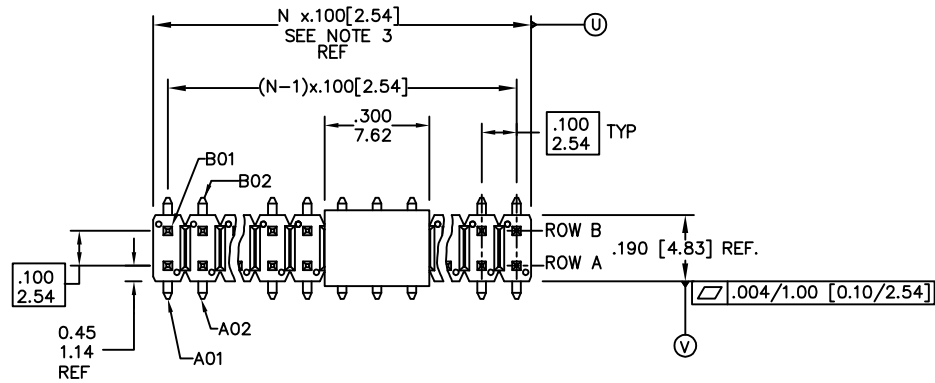

mat'l. code SEE NOTES 1&2		surface ISO 1302 ✓		tolerance ISO 406 ISO 1101		projection INCH/MM		product family BERGSTIK	
ltr		ecn no		dr		date		title	
AB								.100 UNSHROUDED HDR DUAL ROW VERT. SMT.	
		angles		linear		scale 1:1		dwg no	
		0°±2'		.XXX±.01/.XX±.03 .XXX±.005/.XX±.013 .XXX±.0020/.XXX±.0051		FCI		sheet 2 of 4 size	
		dr		enr		chr		54202	
		D.INGRAM		H.SUNDAY		H.SUNDAY		A3	
		1999-05-17		1999-07-21		1999-07-21		type	
		appd		H.SUNDAY		1999-07-21		Product Customer Drawing	
sheet index		revision sheet							

TAPE AND REEL PACKAGING		
SIZE	LEAD STYLE 08 POST (0.230 [5.84])	LEAD STYLE 30 POST (0.318 [8.08])
2X2	YES	YES
2X3	YES	
2X4	YES	YES
2X5	YES	
2X6	YES	
2X7	YES	YES
2X8	YES	
2X9	YES	
2X10	YES	
2X11	YES	
2X12	YES	YES
2X13	YES	
2X14	YES	
2X15	YES	
2X16	YES	YES
2X17	YES	
2X18	YES	
2X19	YES	
2X20	YES	

Cross Reference

CORE RANGE	EXTENDED RANGE
54202-X08XXLF	95278-X01-XXLF
54202-X30XXLF	95278-X02-XXLF

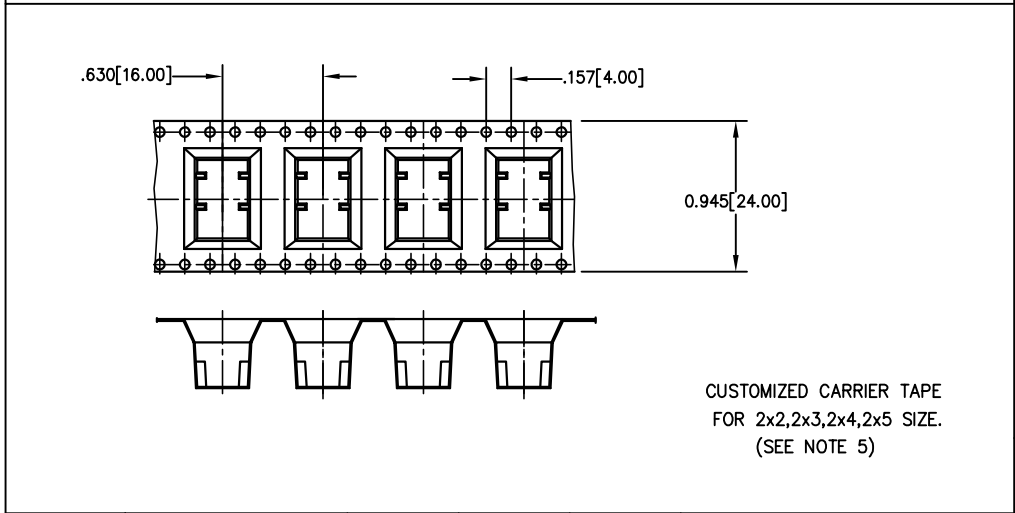
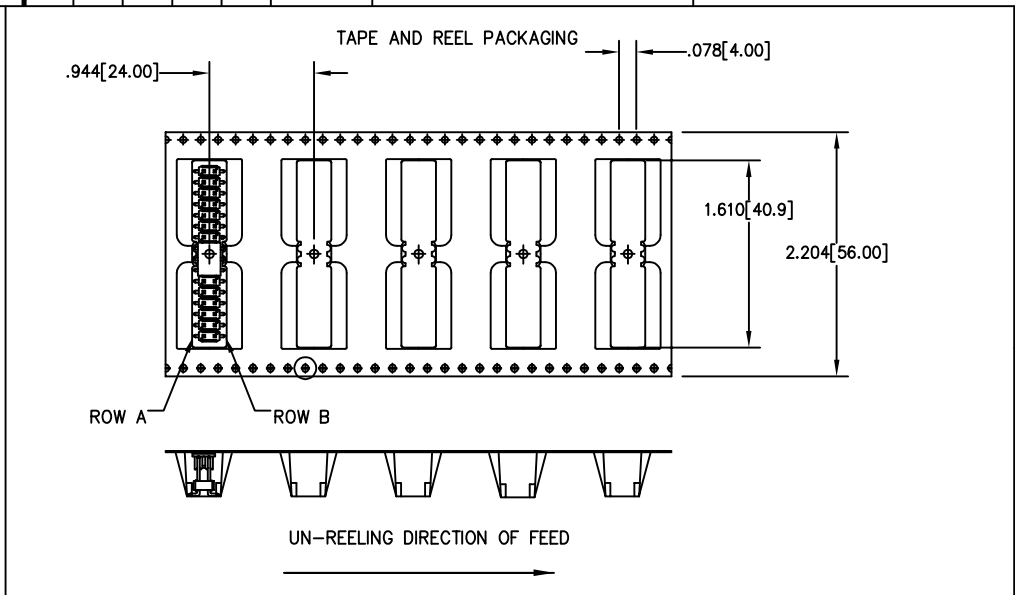

CUSTOMIZED CARRIER TAPE
FOR 2x2,2x3,2x4,2x5 SIZE.
(SEE NOTE 5)

mat'l. code SEE NOTES 1&2		surface ISO 1302 ✓		tolerance ISO 406 ISO 1101		projection INCH/MM		product family BERGSTIK	
ltr ecn no dr date		tolerances unless otherwise specified		linear		INCH/MM		title .100 UNSHROUDED HDR DUAL ROW VERT. SMT.	
AB		angles		0°±2'		scale 1:1		dwg no 54202	
		dr		D.INGRAM 1999-05-17		sheet 3 of 4		size A3	
		enr		H.SUNDAY 1999-07-21		FCI		type Product Customer Drawing	
		chr		H.SUNDAY 1999-07-21					
		appd		H.SUNDAY 1999-07-21					
sheet index		revision sheet							



FCIconnect.com

Copyright FCI

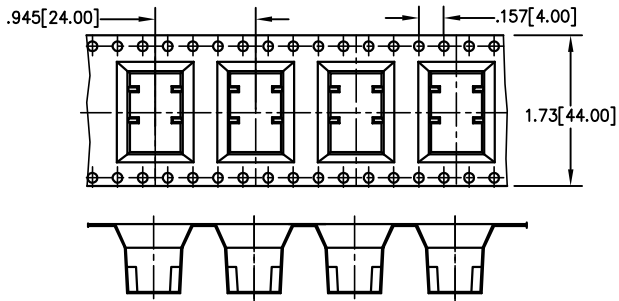

UN-REELING DIRECTION OF FEED

54202-****SLF
SPECIAL REQUEST CARRIER TAPE
FOR 2x5 SIZE(SEE NOTES 5)

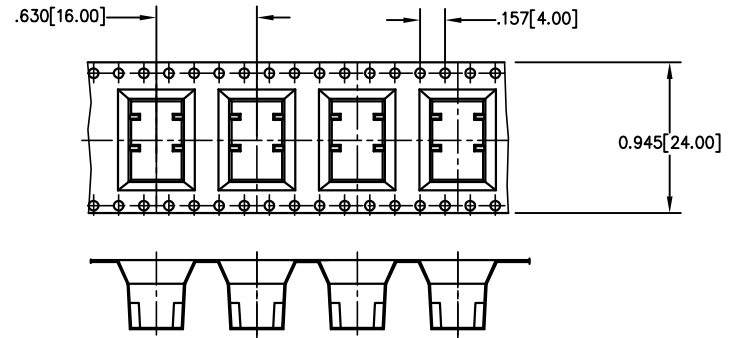

UN-REELING DIRECTION OF FEED

54202-****MLF
TAPE AND REEL WITH PICK UP
CAP FOR SPECIAL CUSTOMER
FOR 2x5 SIZE(SEE NOTES 5)

mat'l. code SEE NOTES 1&2		surface ISO 1302 ✓		tolerance ISO 406 ISO 1101		projection 		product family BERGSTIK	
ltr	ecn	no	dr	date		tolerances unless otherwise specified		title	
AB						angles	linear	INCH/MM	
						0°±2'		.100 UNSHROUDED HDR DUAL ROW VERT. SMT.	
						dr	D.INGRAM	1999-05-17	scale 1:1
						enr	H.SUNDAY	1999-07-21	dwg no
						chr	H.SUNDAY	1999-07-21	sheet 4 of 4
						appd	H.SUNDAY	1999-07-21	size A3
sheet index		revision sheet						type Product Customer Drawing	

form: A3