



Chipsmall Limited consists of a professional team with an average of over 10 year of expertise in the distribution of electronic components. Based in Hongkong, we have already established firm and mutual-benefit business relationships with customers from,Europe,America and south Asia,supplying obsolete and hard-to-find components to meet their specific needs.

With the principle of “Quality Parts,Customers Priority,Honest Operation,and Considerate Service”,our business mainly focus on the distribution of electronic components. Line cards we deal with include Microchip,ALPS,ROHM,Xilinx,Pulse,ON,Everlight and Freescale. Main products comprise IC,Modules,Potentiometer,IC Socket,Relay,Connector.Our parts cover such applications as commercial,industrial, and automotives areas.

We are looking forward to setting up business relationship with you and hope to provide you with the best service and solution. Let us make a better world for our industry!



Contact us

Tel: +86-755-8981 8866 Fax: +86-755-8427 6832

Email & Skype: info@chipsmall.com Web: www.chipsmall.com

Address: A1208, Overseas Decoration Building, #122 Zhenhua RD., Futian, Shenzhen, China



THIS DRAWING IS UNPUBLISHED. RELEASED FOR PUBLICATION 20
 © COPYRIGHT 20 ALL RIGHTS RESERVED.

REVISIONS				
P	LTR	DESCRIPTION	DATE	DWN APVD
C2		REVISED PER ECO-11-005140	16APR2011	RK HMR

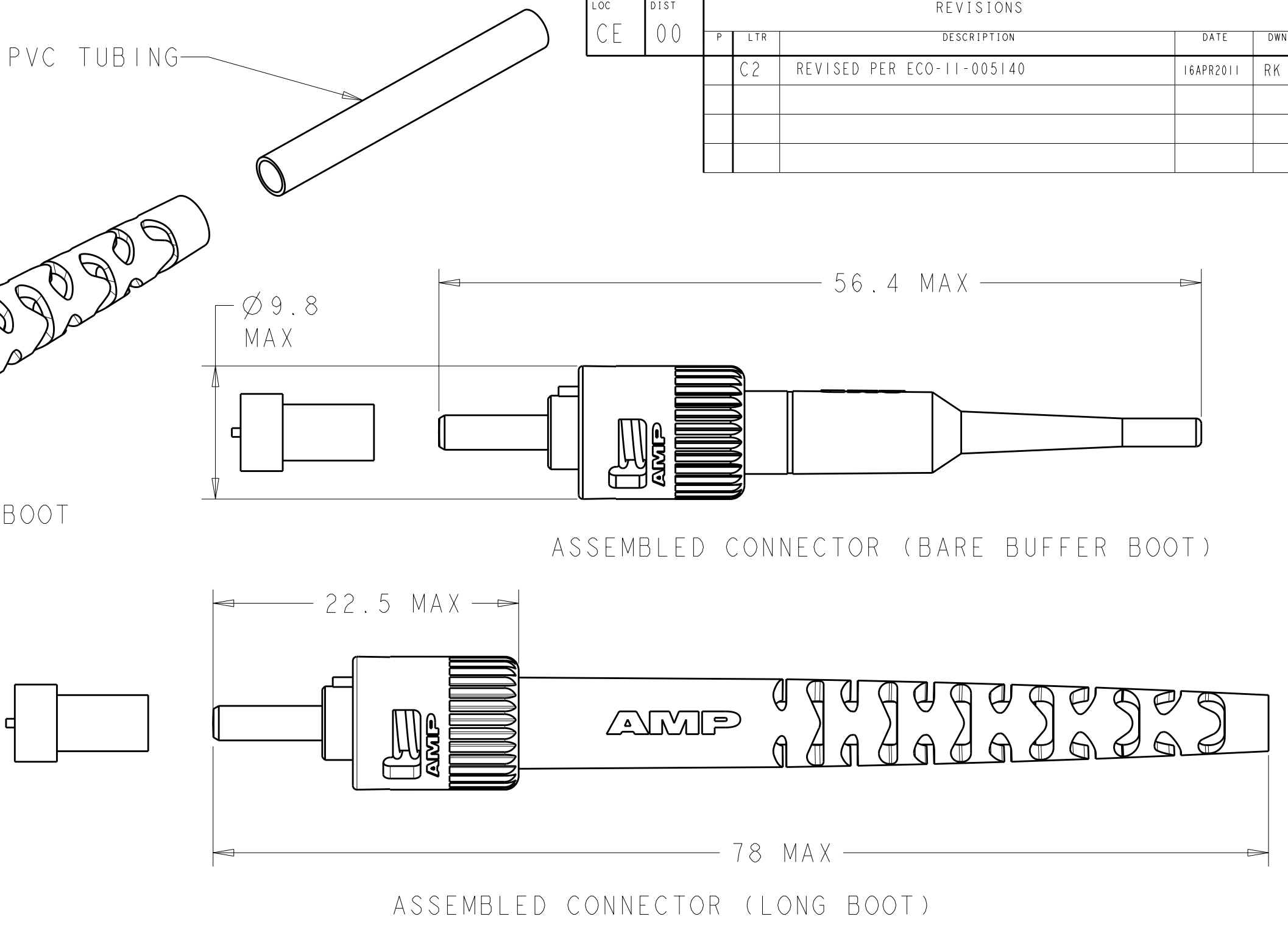
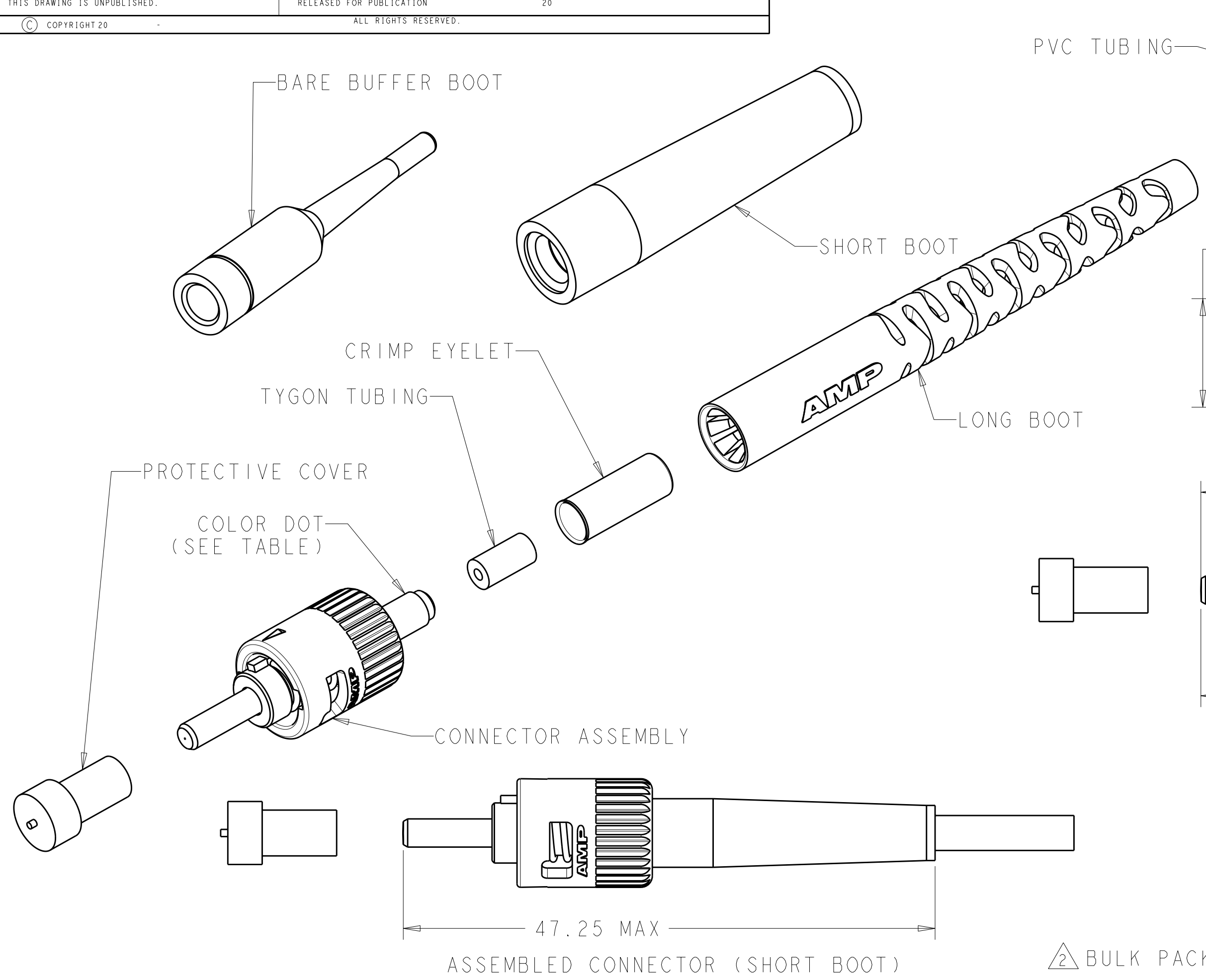

2 BULK PACKAGE.

3. INSTRUCTION SHEET: 408-9971 AVAILABLE FOR DOWNLOAD AT www.tycoelectronics.com/documents OR www.ampnetconnect.com/foguide.

- 1 MATERIAL:
- PROTECTIVE COVER: LDPE, COLOR: BLACK, NON-FR.
 - CONNECTOR ASSEMBLY:
 - FERRULE ASSEMBLY: CERAMIC/NICKEL PLATED BRASS.
 - SPRING: STAINLESS STEEL.
 - COUPLING NUT: ZINC.
 - RETENTION RING: STAINLESS STEEL.
 - CRIMP EYELET: TIN PLATED COPPER.
 - LONG BOOT: TPE, UL94 HB RATED AT QUALIFYING THICKNESS, SEE DASH NUMBER FOR COLOR.
 - SHORT BOOT: TPE, UL94 V-0 RATED AT QUALIFYING THICKNESS, SEE DASH NUMBER FOR COLOR.
 - BUFFER BOOT: TPE, UL94 V-0 RATED AT QUALIFYING THICKNESS, SEE DASH NUMBER FOR COLOR.
 - TYGON TUBING: TYGON, COLOR: CLEAR.
 - PVC TUBING: PVC, COLOR: BLACK, NON-FR.

DESCRIPTION	BOOT COLOR	COLOR DOT	FIBER SIZE	PART NUMBER
SHORT BOOT	BLACK	-	125um	2-5501380-0
SHORT BOOT	BLACK	-	125um	1-5501380-6
LONG BOOT	BLACK	GREEN	140um	5501380-6
BARE BUFFER AND LONG BOOT	BLACK	-	125um	5501380-1

THIS DRAWING IS A CONTROLLED DOCUMENT.		DWN B. BRIGGS 27APR2005	TE Connectivity	
DIMENSIONS: mm		CHK S. BUCHTER 27APR2005		
TOLERANCES UNLESS OTHERWISE SPECIFIED:		APVD S. BUCHTER 27APR2005		
0 PLC ± 1 PLC ± 2 PLC ± 3 PLC ± 4 PLC ± ANGLES ± FINISH		NAME		
MATERIAL		PRODUCT SPEC	CONNECTOR KIT, 2.5mm BAYONET	
		APPLICATION SPEC	SIZE	RESTRICTED TO
		WEIGHT	A200779	
		CUSTOMER DRAWING	CAGE CODE	
			DRAWING NO	
			G=5501380	
			SCALE 3:1	
			SHEET 1 OF 1	
			REV C2	