



Chipsmall Limited consists of a professional team with an average of over 10 year of expertise in the distribution of electronic components. Based in Hongkong, we have already established firm and mutual-benefit business relationships with customers from,Europe,America and south Asia,supplying obsolete and hard-to-find components to meet their specific needs.

With the principle of "Quality Parts,Customers Priority,Honest Operation,and Considerate Service",our business mainly focus on the distribution of electronic components. Line cards we deal with include Microchip,ALPS,ROHM,Xilinx,Pulse,ON,Everlight and Freescale. Main products comprise IC,Modules,Potentiometer,IC Socket,Relay,Connector.Our parts cover such applications as commercial,industrial, and automotives areas.

We are looking forward to setting up business relationship with you and hope to provide you with the best service and solution. Let us make a better world for our industry!



## Contact us

Tel: +86-755-8981 8866 Fax: +86-755-8427 6832

Email & Skype: info@chipsmall.com Web: www.chipsmall.com

Address: A1208, Overseas Decoration Building, #122 Zhenhua RD., Futian, Shenzhen, China



THIS DRAWING IS UNPUBLISHED. RELEASED FOR PUBLICATION  
 © COPYRIGHT - By - ALL RIGHTS RESERVED.

LOC		DIST		REVISIONS			
P	LTR	DESCRIPTION	DATE	DWN	APVD		
AA	00	B1	REVISED PER ECO-11-005033	23MAR11	RK	HMR	

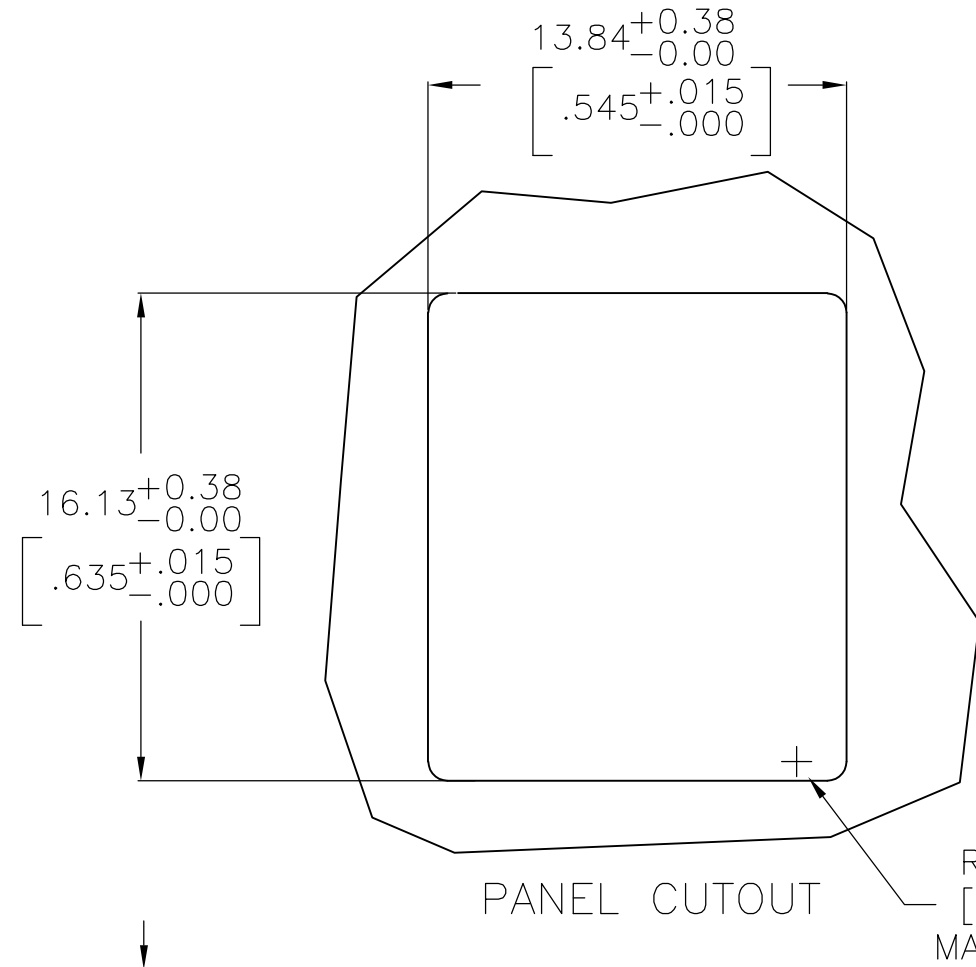
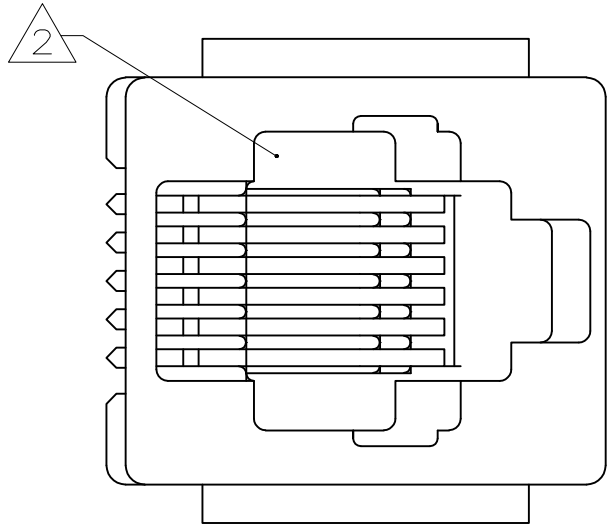

1. MATERIAL: HOUSING - BLACK PBT POLYESTER, BLACK, UL 94V-0.  
 TERMINAL - 0.36 [.014] THICK PHOS-BRONZE PLATED WITH 1.27µm [.000050] MINIMUM THICK GOLD IN LOCALIZED AREA AND 3.81µm [.000150] MINIMUM THICK MATTE TIN IN SOLDER AREA OVER 1.27µm [.000050] MINIMUM THICK NICKEL UNDERPLATE.

- ⚠ JACK CAVITY CONFORMS TO FCC RULES AND REGULATIONS PART 68 AND REA BULLETIN 345-81, PE-76 SPECIFICATION FOR MODULAR TELEPHONE HARDWARE.
- ⚠ BULK PACKAGE IN A TRAY
- ⚠ PACKAGED 28 PIECES PER TUBE

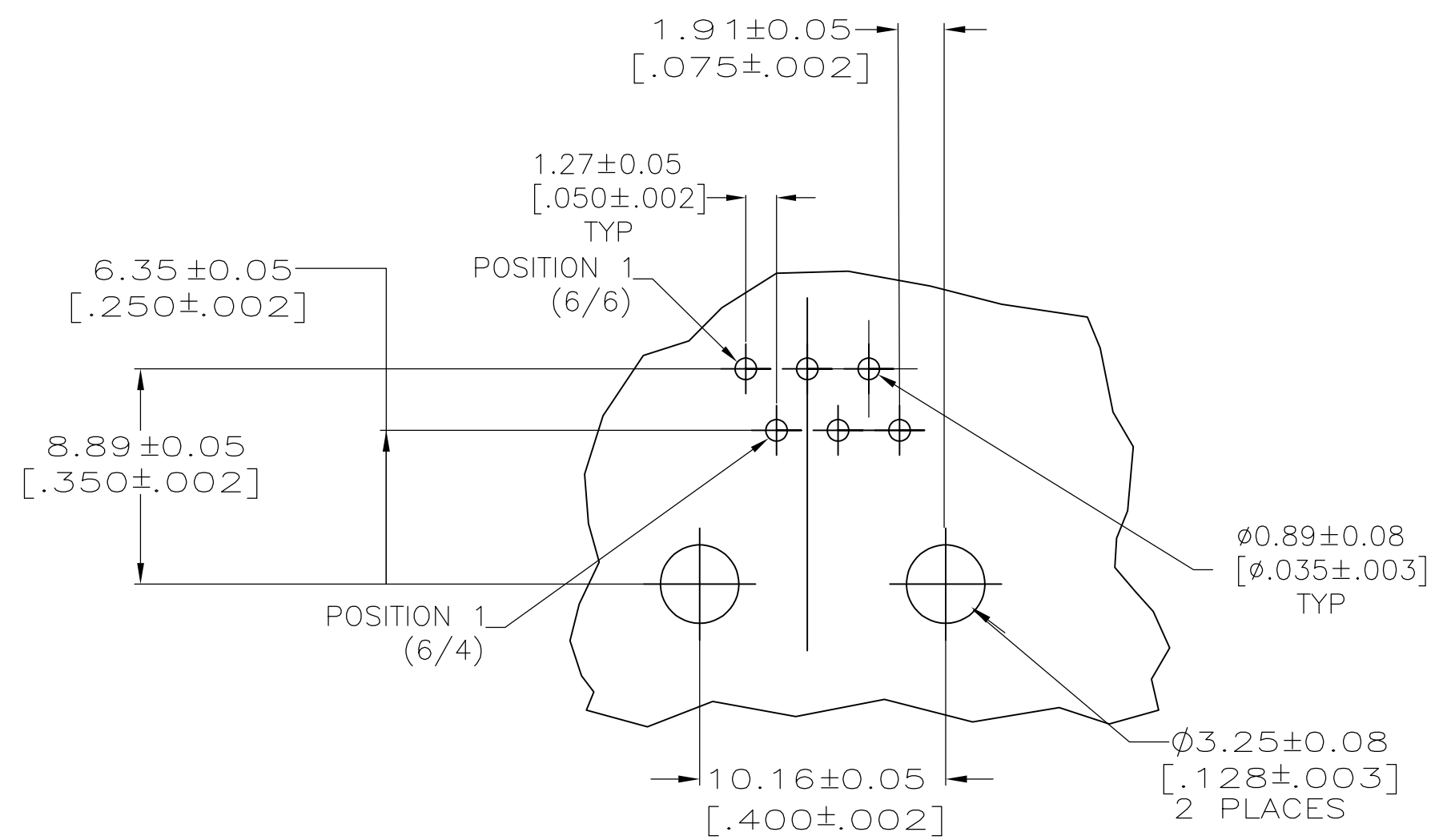
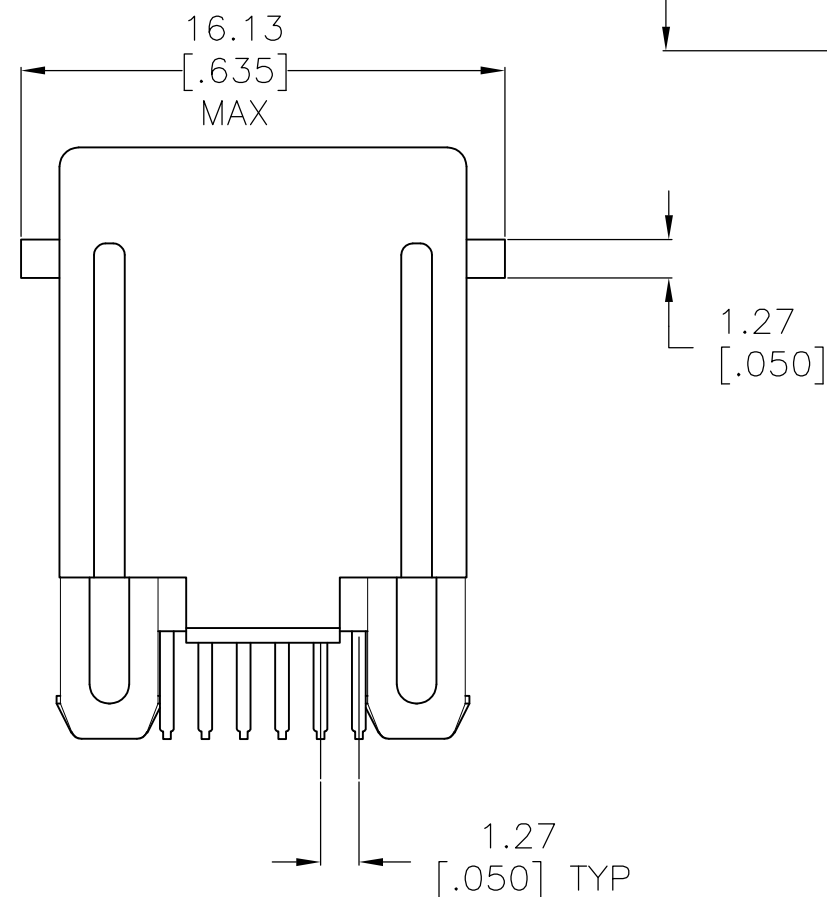
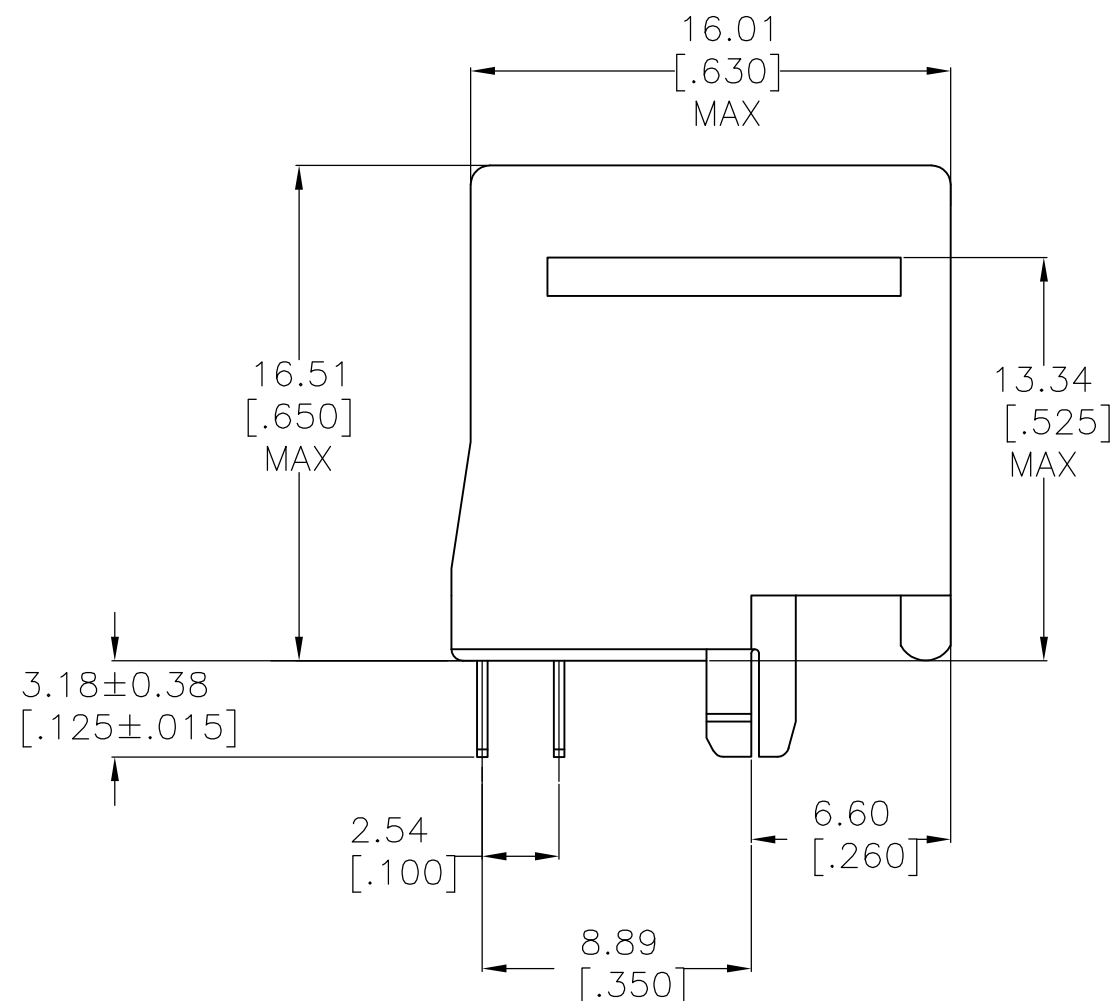

SUGGESTED PC BOARD LAYOUT  
 COMPONENT SIDE

⚠	6	5520258-4
	6	5520258-3
	4	5520258-2
PACKAGED	CONTACTS	PART NUMBER

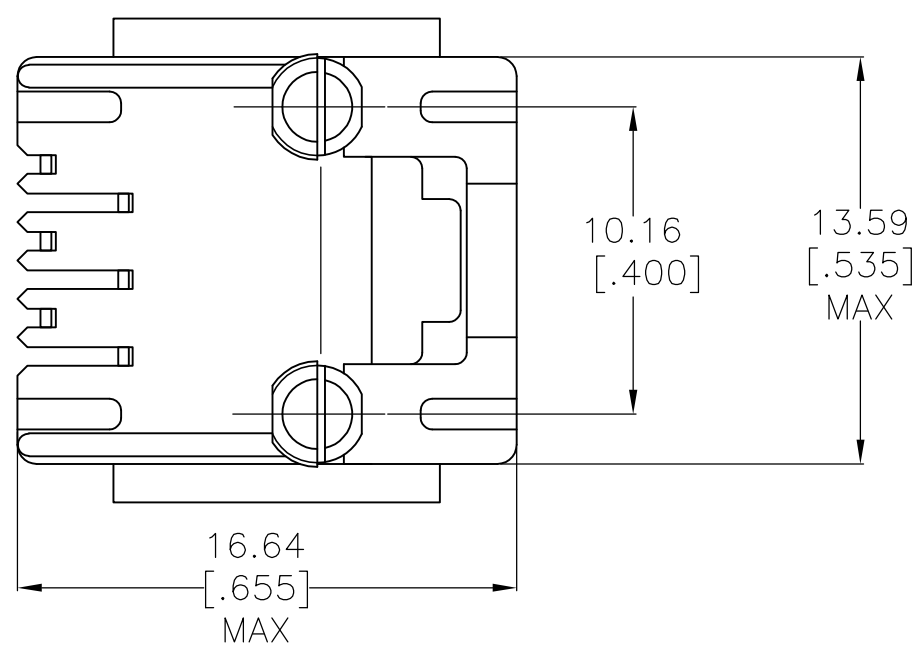

THIS DRAWING IS A CONTROLLED DOCUMENT.		DWN	L.A.MAYER	16AUG2007	 TE Connectivity		
DIMENSIONS: mm [INCHES]		CHK	P.RECCE	16AUG2007			
TOLERANCES UNLESS OTHERWISE SPECIFIED:		APVD	S. FLICKINGER	16AUG2007			
0 PLC ± - 1 PLC ± - 2 PLC ± 0.13[.005] 3 PLC ± - 4 PLC ± - ANGLES ± - FINISH SEE NOTE 1		NAME	PRODUCT SPEC 108-1163 APPLICATION SPEC 114-2048				
MATERIAL SEE NOTE 1		WEIGHT	-		SIZE	A2	
		CUSTOMER DRAWING		SCALE	4:1	SHEET	1 OF 1
				REV	B1		