



Chipsmall Limited consists of a professional team with an average of over 10 year of expertise in the distribution of electronic components. Based in Hongkong, we have already established firm and mutual-benefit business relationships with customers from,Europe,America and south Asia,supplying obsolete and hard-to-find components to meet their specific needs.

With the principle of “Quality Parts,Customers Priority,Honest Operation,and Considerate Service”,our business mainly focus on the distribution of electronic components. Line cards we deal with include Microchip,ALPS,ROHM,Xilinx,Pulse,ON,Everlight and Freescale. Main products comprise IC,Modules,Potentiometer,IC Socket,Relay,Connector.Our parts cover such applications as commercial,industrial, and automotives areas.

We are looking forward to setting up business relationship with you and hope to provide you with the best service and solution. Let us make a better world for our industry!



## Contact us

Tel: +86-755-8981 8866 Fax: +86-755-8427 6832

Email & Skype: info@chipsmall.com Web: www.chipsmall.com

Address: A1208, Overseas Decoration Building, #122 Zhenhua RD., Futian, Shenzhen, China



**NOTE**



All numerical values are in metric units [with U.S. customary units in brackets]. Dimensions are in millimeters [and inches]. Unless otherwise specified, dimensions have a tolerance of  $\pm 0.13$  [ $\pm 0.005$ ] and angles have a tolerance of  $\pm 2^\circ$ . Figures and illustrations are for identification only and are not drawn to scale.

**1. INTRODUCTION**

This specification covers the requirements for application of CHAMP Cable Connectors (standard and shielded). These requirements are applicable for hand or automatic machine installation. These CHAMP Cable Connectors are intermateable and interchangeable with existing connectors of a similar design. The CHAMP Connector product line is ideally suited for use in all phases of the telecommunications industry, computer terminals, test equipment, business and copying machines, telemetering, and various equipment used in the security industry. The standard CHAMP Cable Connectors are available in 14-, 24-, 36-, 50-, and 64-position sizes. The shielded CHAMP Cable Connectors are available in 24-, 36-, and 50- position sizes.

When corresponding with TE Connectivity personnel, use the terminology provided in this specification to facilitate your inquiries for information. Basic terms and features of this product are provided in Figure 1.

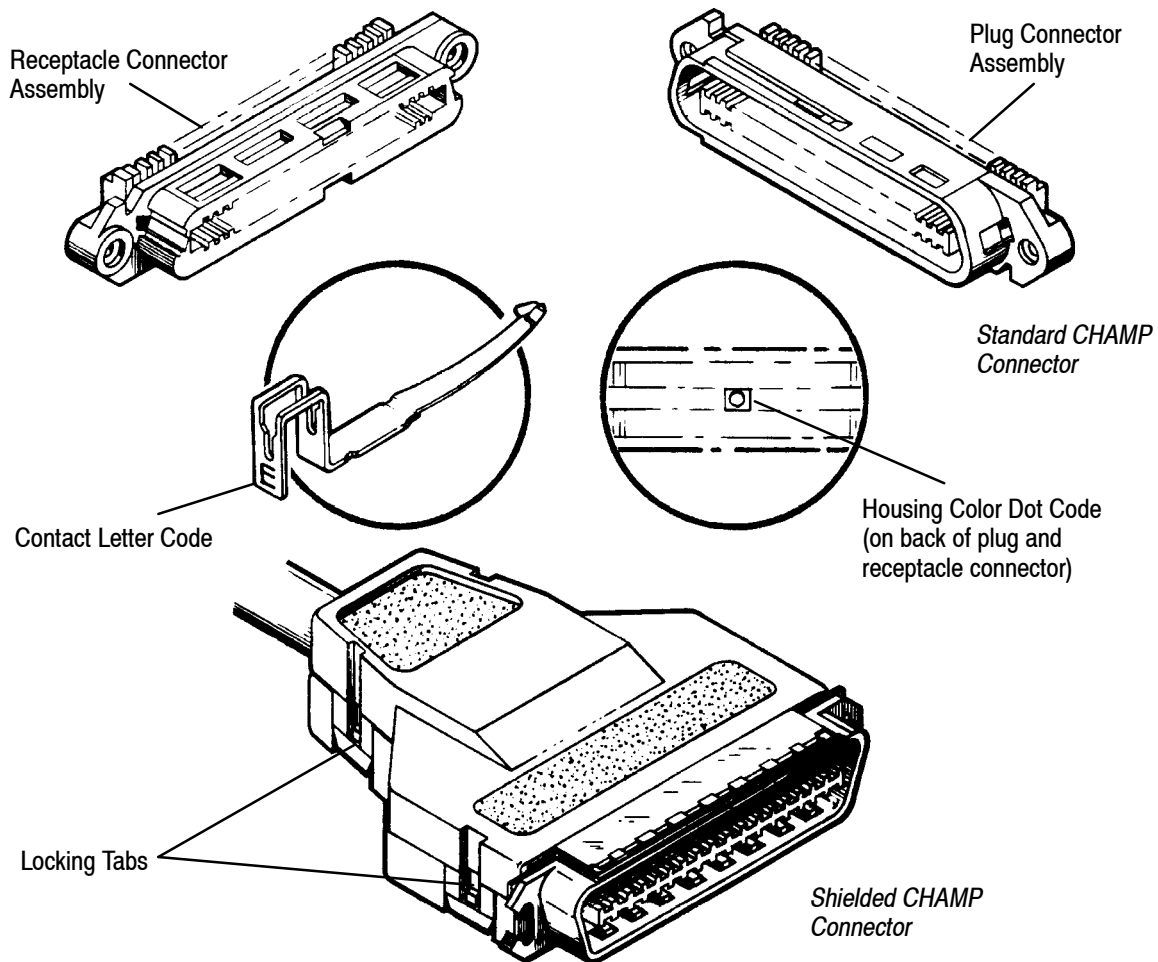

Figure 1

---

## 2. REFERENCE MATERIAL

### 2.1. Revision Summary

- Updated document to corporate requirements.

### 2.2. Customer Assistance

Reference Part Number 229974 and Product Code 1210 are representative numbers that identify the CHAMP Cable Connectors. These numbers are used in the network of customer service to access tooling and product application information. This service is provided by your local TE Representative or, after purchase, by calling the Product Information number at the bottom of page 1.

### 2.3. Drawings

Customer Drawings for specific products are available from the responsible TE Engineering Department via the service network. The information contained in the Customer Drawings takes priority if there is a conflict with this specification or with any other technical documentation supplied by TE.

### 2.4. Specifications

Product Specification 108-6005 provides applicable performance requirements and test data relative to CHAMP Cable Connectors.

### 2.5. Instructional Material

The following list includes available instruction sheets (408-series) that provide assembly procedures for product, operation, maintenance and repair of tooling, as well as setup and operation procedures of applicators; and customer manuals (409-series) that provide setup, operation, and maintenance procedures of machines.

<u>Document Number</u>	<u>Document Title</u>
408-3133	CHAMP Discrete Wire Tooling Assembly 231593-2
408-3137	CHAMP Laminated Cable Tooling Assembly 231592-2
408-3159	Strain Relief Hardware For CHAMP Connectors
408-3160	Mounting Hardware For CHAMP Connectors
408-3188	Shielded CHAMP 180 Connector Kits and Cover Kits
408-7558	CHAMP T-Handle Wire Insertion Tool 229384-1
408-7559	CHAMP Portable Hand Operated Tool (MI-1) 229378
408-7564	CHAMP Cable-to-Cable and Cable-to-Panel Connectors
408-7642	Palm Grip Hand Tool Kit 229764-2
408-7787	Insertion/Extraction Tool 230238-1
409-5411	CHAMPOMATOR* Insertion Machine
409-5771	CHAMPOMATOR 3A Terminating Machine

## 3. REQUIREMENTS

### 3.1. Wire

#### A. Selection

Contacts are available for the wire sizes specified in the chart in Figure 2. Housing assemblies (plug/receptacle) are also specified in Figure 2. The wires may be solid or stranded.

#### B. Wire Size

The color dots on the housings and the letter codes on the contacts designate wire size.

WIRE SIZE ■		HOUSING COLOR DOT CODE	CONTACT LETTER CODE
SOLID	7 STRAND		
22	22	Green	C
22	22	Brown	F●
24-26	24	Blue	B
---	26-27-28	Yellow	E

**NOTES:** ■ All connector styles may not be available in each position and each wire size. ● Connectors for large insulation diameter wire (1.42 mm [.056 in.] maximum).

Figure 2

### C. Wire Placement

Wire must be below transition of lead-in to contact slot as indicated in Figure 3. See Figure 4 for F slot contact wire placement.

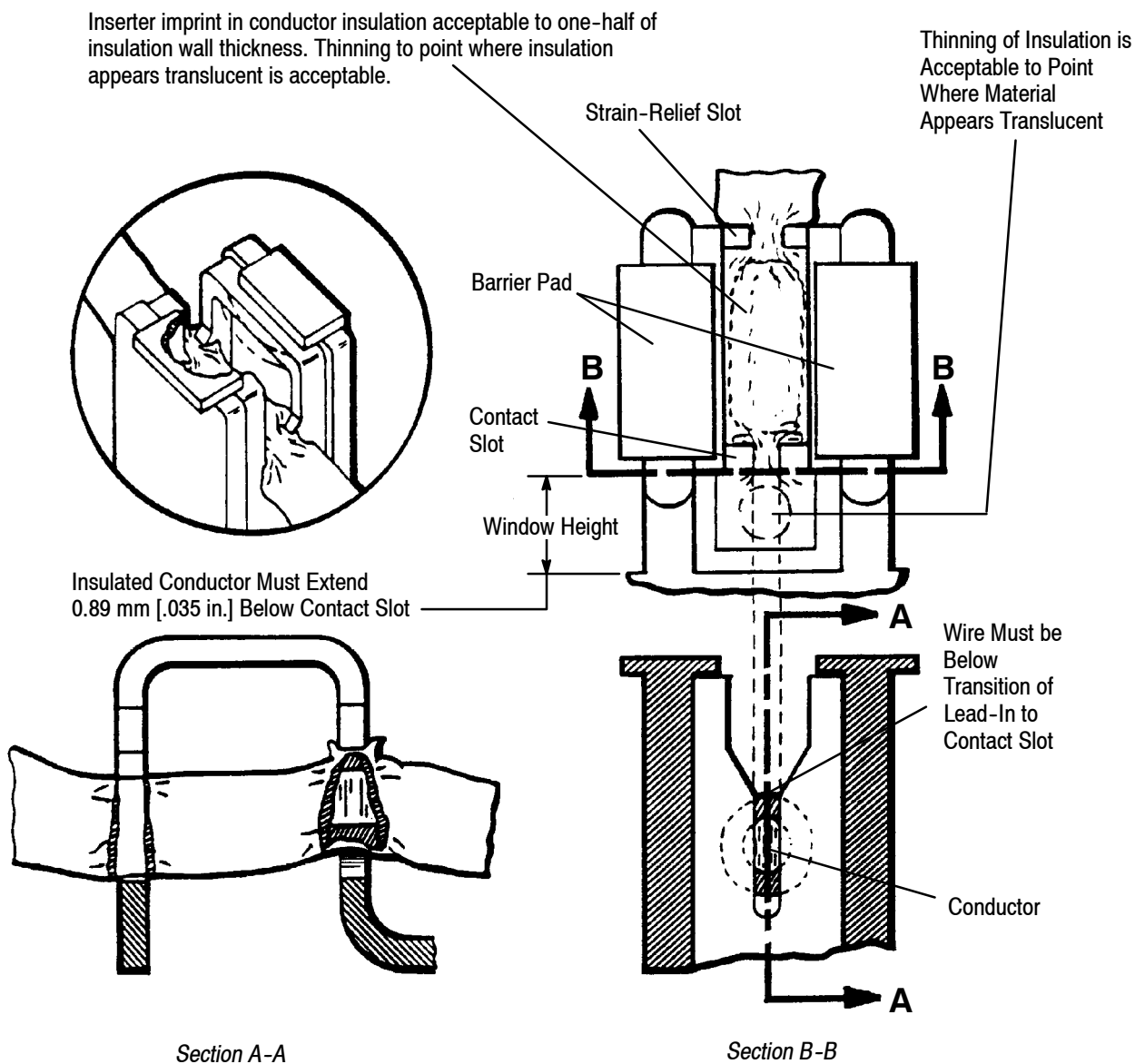

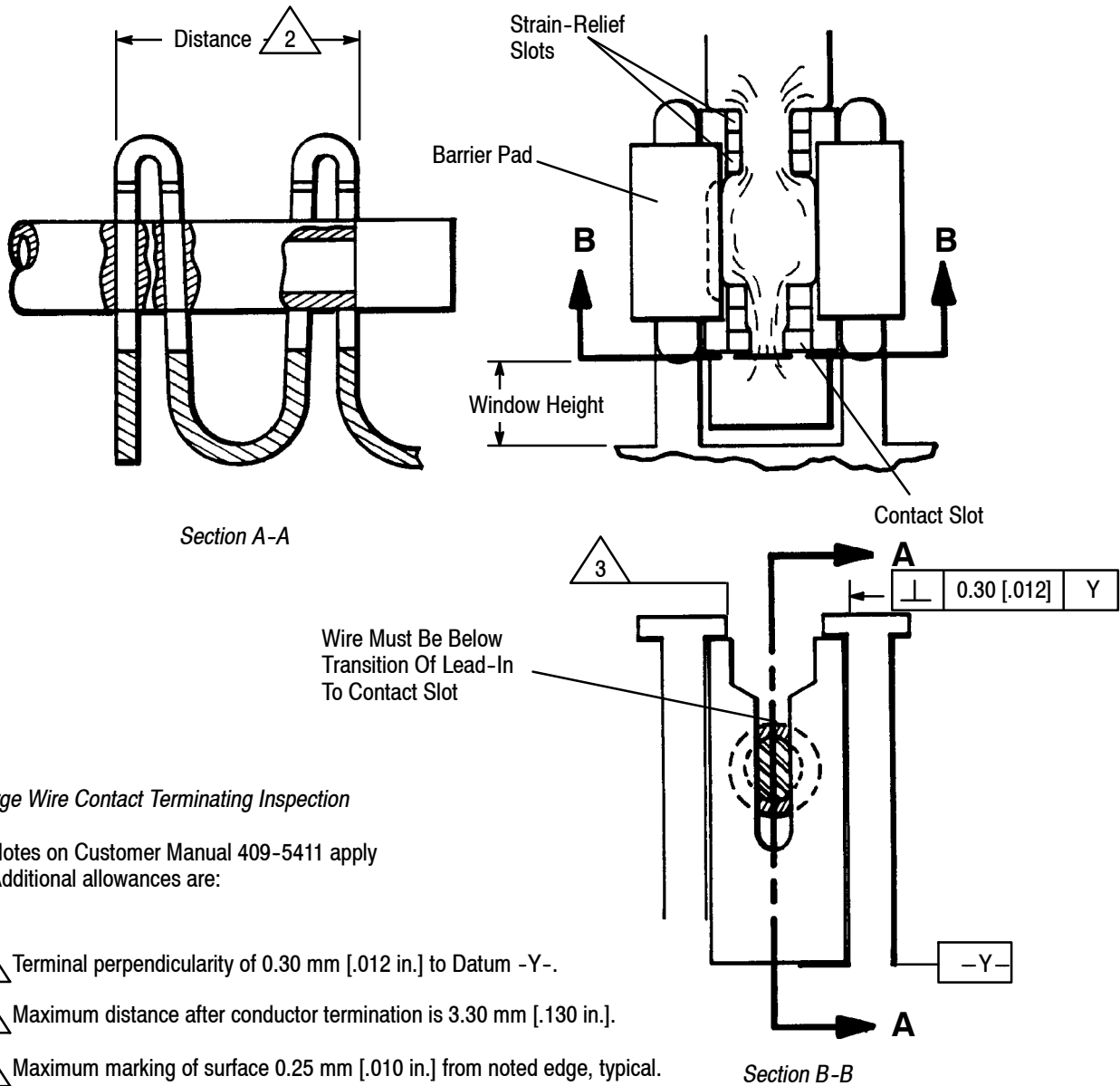

#### Large Wire Contact Terminating Inspection

- Notes on Customer Manual 409-5411 apply
- Additional allowances are:

- 1 Terminal perpendicularity of 0.30 mm [.012 in.] to Datum -Y-.
- 2 Maximum distance after conductor termination is 3.30 mm [.130 in.].
- 3 Maximum marking of surface 0.25 mm [.010 in.] from noted edge, typical.

Figure 4

#### D. Wire Exposure

Insulated conductor must extend 0.89 mm [.035 in.] below contact slot.

#### E. Insulation Range

Insulation range for standard cable connectors should be 1.14 mm [.045 in.] maximum diameter for tools that mass terminate conductors on one side at a time. For tools that insert one conductor per side at a time, 1.09 mm [.043 in.] insulation diameter is the maximum. Insulation range for F slot contacts is 1.42 mm [.056 in.] maximum diameter.

#### F. Workmanship

Minor nicks and scrapes or saddling of the metal bridge are acceptable provided the two slots remain parallel to each other and perpendicular to the housing. Minor plastic shaving and rolling over of barrier pads are acceptable provided that contacts are not damaged. Shaving of barrier pads is acceptable up to 0.15 mm [.006 in.] maximum in direction of connector length. Nicks in the insulation above the connector should not exceed one half of insulation wall thickness.

## G. Inserter Imprint

Inserter imprint in conductor insulation should not exceed one half of insulation wall thickness. Thinning of insulation is acceptable to the point where the insulation appears translucent.

### 3.2. Shielded CHAMP Cable Connectors

Shielded CHAMP Cable Connectors consist of contacts on 2.16 mm [.085 in.] centerlines; pre-assembled housings with 24, 36, or 50 slotted contacts; a choice of two wire slot sizes, B or E; bail-lock or screw-lock hardware, with metric hardware for IEEE applications; 180° cable entry; and the same full tooling capabilities that are used with standard CHAMP Cable Connectors.

The main design difference in shielded CHAMP Cable Connectors is the addition of small holes or windows around the peripheral skirt of each plug housing. These holes accept the spring fingers of a two-piece wraparound metal shield. The spring fingers interact with the contact plates on the receptacle connector and thus provide minimal leakage and maximum shielding effectiveness.

The application requirements are basically the same (except where noted otherwise) for shielded and standard CHAMP Cable Connectors.

### 3.3. Locking Hardware

Locking hardware is used to secure mating CHAMP Connectors and to prevent accidental separation. Refer to Instruction Sheet 408-3160 for further information. See Figure 5 for the different types of locking hardware.

#### A. Locking Latch (CHAMP-LOK\* Connector Design)

Standard CHAMP connectors (except for IEEE applications) have guide tracks and slots (on plugs) and lead-in ramps (on receptacles) to allow the use of a metal locking clip for securing connectors.

#### B. Screw-Lock Hardware

Screw-lock hardware is used in applications where positive locking is required to secure connectors to pc boards, to panels, and/or to each other. In cable-to-cable applications, two captive screws threaded into pre-tapped holes are generally the only screw-lock requirements.

#### C. Bail-Lock Hardware (Standard or Bent)

Bail-lock hardware provides both locking and quick-release capabilities at both ends of mated connectors. Flanges on CHAMP plug connectors must be open ended for all bail-lock applications. The open-end flanges accept bail clips which are used primarily with right angle (90°) cable terminations where space is limited.

#### D. J-Hook Hardware

The J-hook is a precision-formed metal bracket used as an alternate quick-fastening method for assembly hardware. Two tabs fit into recesses in the connector housing flange for screw-fastening. The inverted end of the J-hook snaps on the end of a mating connector, and holds it in place.

A. CHAMP-LOK :Locking Latch

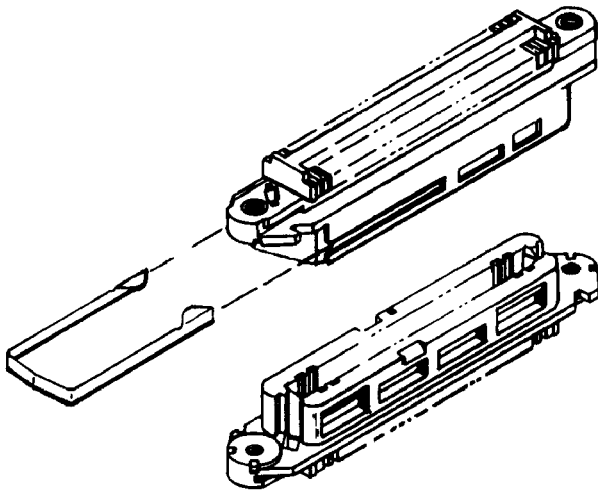

B. Screw-Lock Hardware

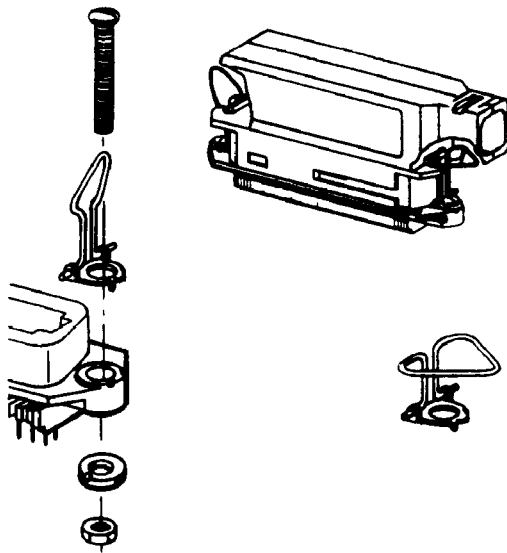
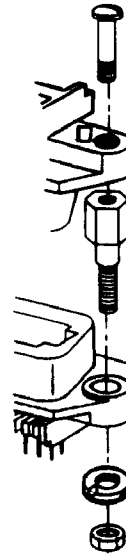

C. Bail-Lock Hardware (Standard/Bent 90 °)

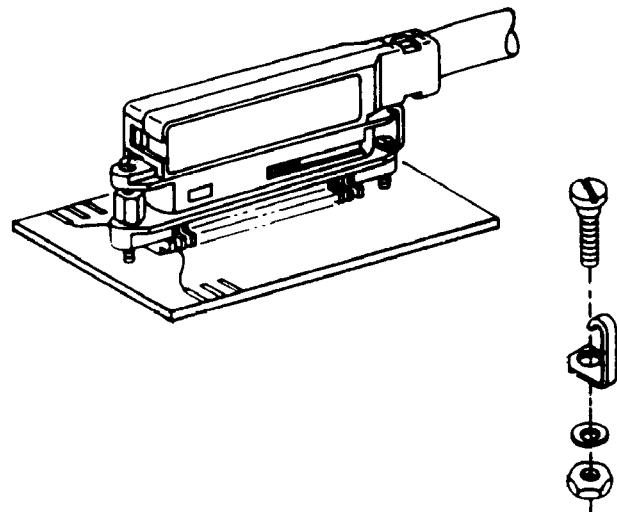

D. J-Hook Hardware

Figure 5

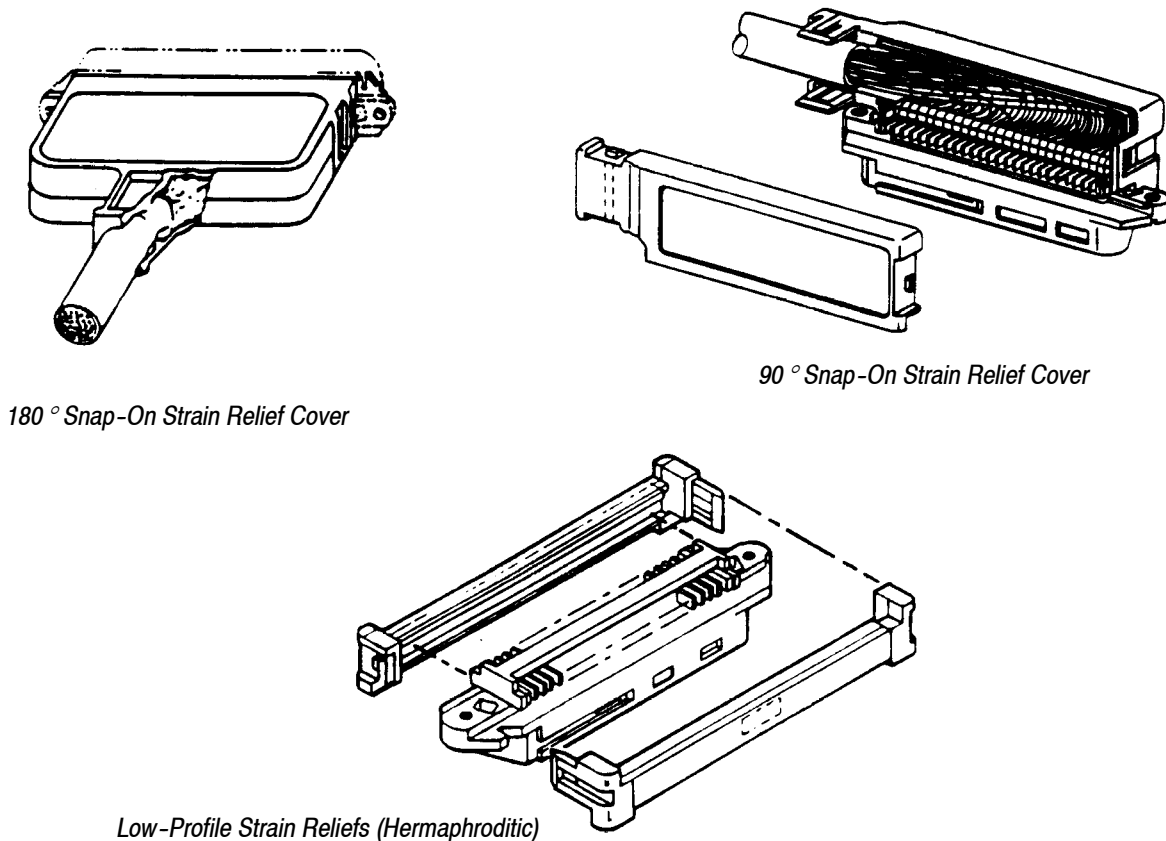

Figure 6

### 3.4. Accessories

CHAMP cable connectors are compatible with the accessories shown in Figures 6 and 7. The instructional material listed with each accessory provides details for product selection and assembly procedures.

#### A. 90° Slide-On Strain Relief Covers

90° Slide-On Strain Relief Covers (Instruction Sheet 408-3159) are available for 50 position CHAMP cable connectors. The covers come in three versions — 90° tapered, 90° straight, 90° straight (adjustable or ratchet style). All three versions are designed for use in cable-to-cable applications; however, the straight (ratchet style) is recommended for use with CHAMP-LOK Connector Locking Latch 552723-1.

#### B. Snap-On Strain Relief Covers

Snap-on strain relief covers (Instruction Sheet 408-3159) are available in both a 90° version and a 180° version.

#### C. Low Profile Strain Relief Covers

Low profile strain relief covers (Instruction Sheet 408-3159) are used in cable-to-panel applications where height is a concern.

#### D. Dust Cover

Dust covers (Instruction Sheet 408-7564) are used to protect the mating face of connectors that are NOT mated.



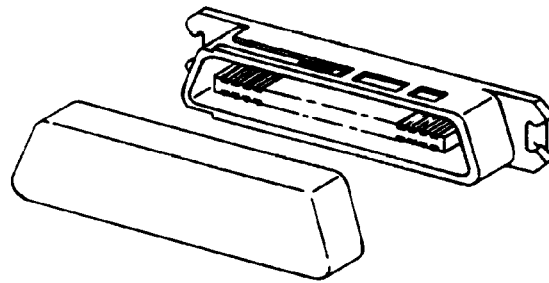

*Dust Covers for Plugs, Receptacles*

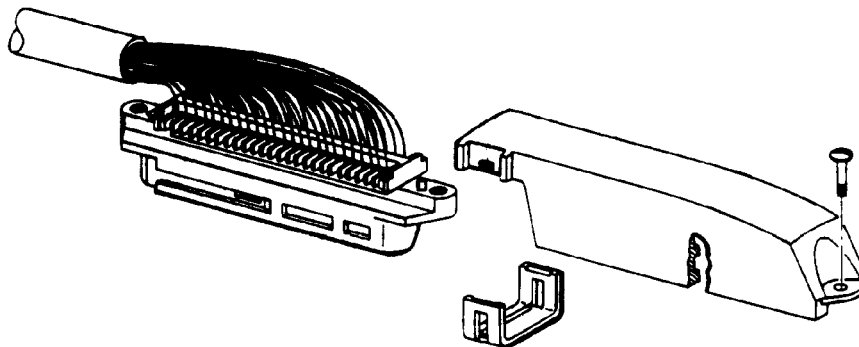
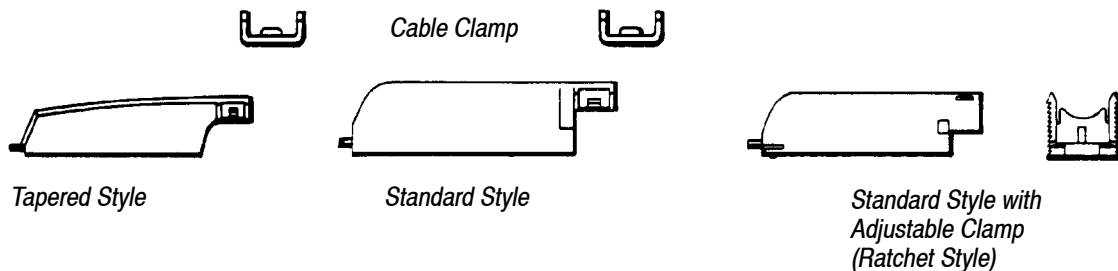

*Three Types of Slide-On Covers for 90 ° Entry (50 Positions Only)*

*Figure 7*

#### 4. QUALIFICATIONS

CHAMP Cable Connectors are Component Recognized by Underwriters Laboratories Inc. (UL) in File E28476 and Listed in File E81956. They are also Certified by CSA International in File LR7189.

#### 5. TOOLING (Figure 8)

For insertion or extraction of CHAMP connector contacts, use Insertion/Extraction Tool 230238 (Instruction Sheet 408-7787). For minor termination repair work, use T-Handle Wire Insertion Tool 229384. For field applications and low volume production, the Palm Grip Hand Tool Kit 229764-2 is recommended. For field applications and medium volume production, the Portable Hand Operated Tool 229378 (Instruction Sheet 408-7559) is recommended. It terminates all CHAMP connectors up to 50 positions with 90° wire dress. For information on other portable hand-operated tools, refer to Instruction Sheet 408-7559. For termination of laminated cables, use CHAMP Arbor Tooling System 231592-2 (Instruction Sheet 408-3137. For termination of discrete wires, use CHAMP Arbor Tooling System 231593-2 (Instruction Sheet 408-3133). For termination of CHAMP connectors in high volume production, use the CHAMPOMATOR Insertion Machine "Model G" (Customer Manual 409-5411) or CHAMPOMATOR 3A (Customer Manual 409-5771).

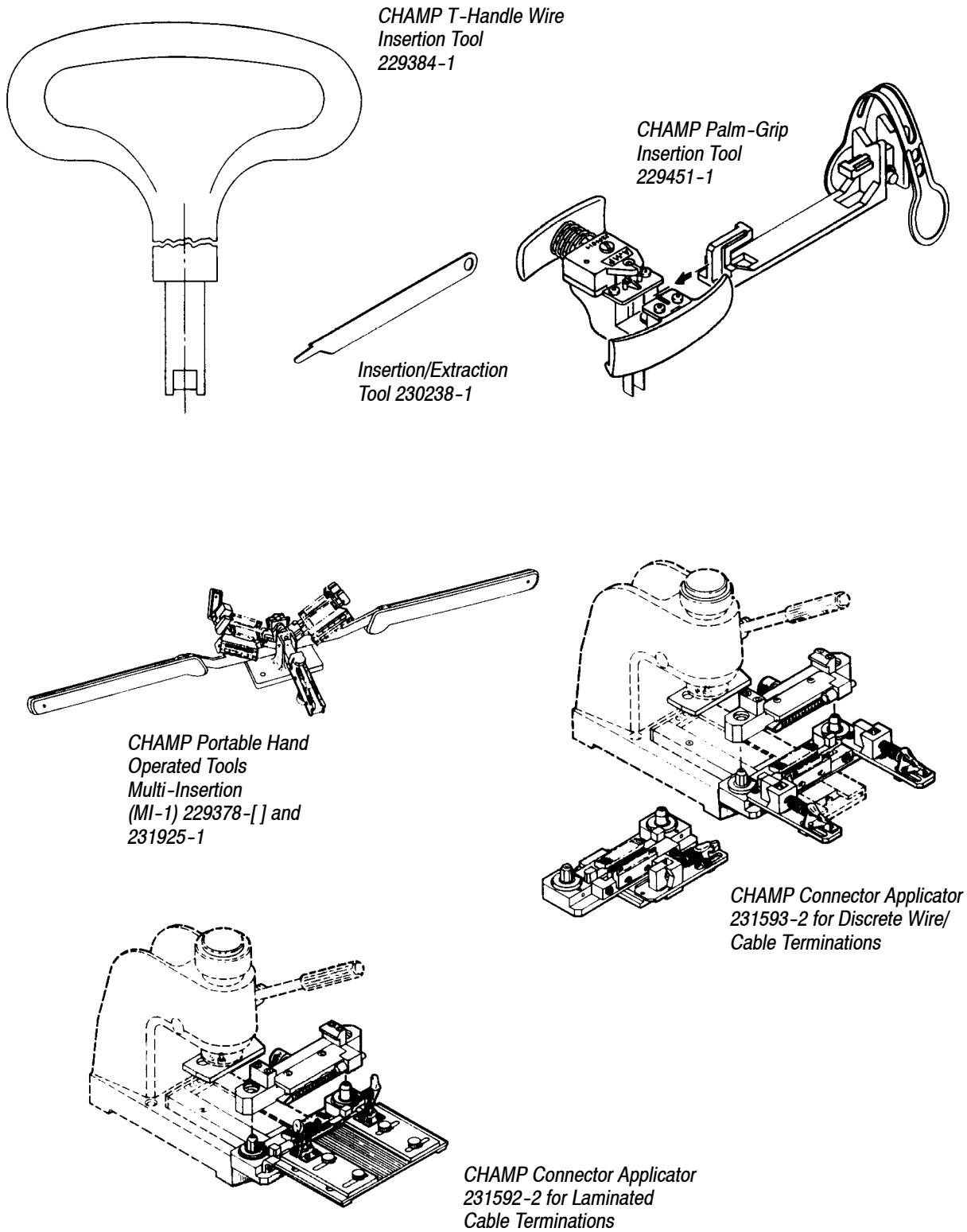
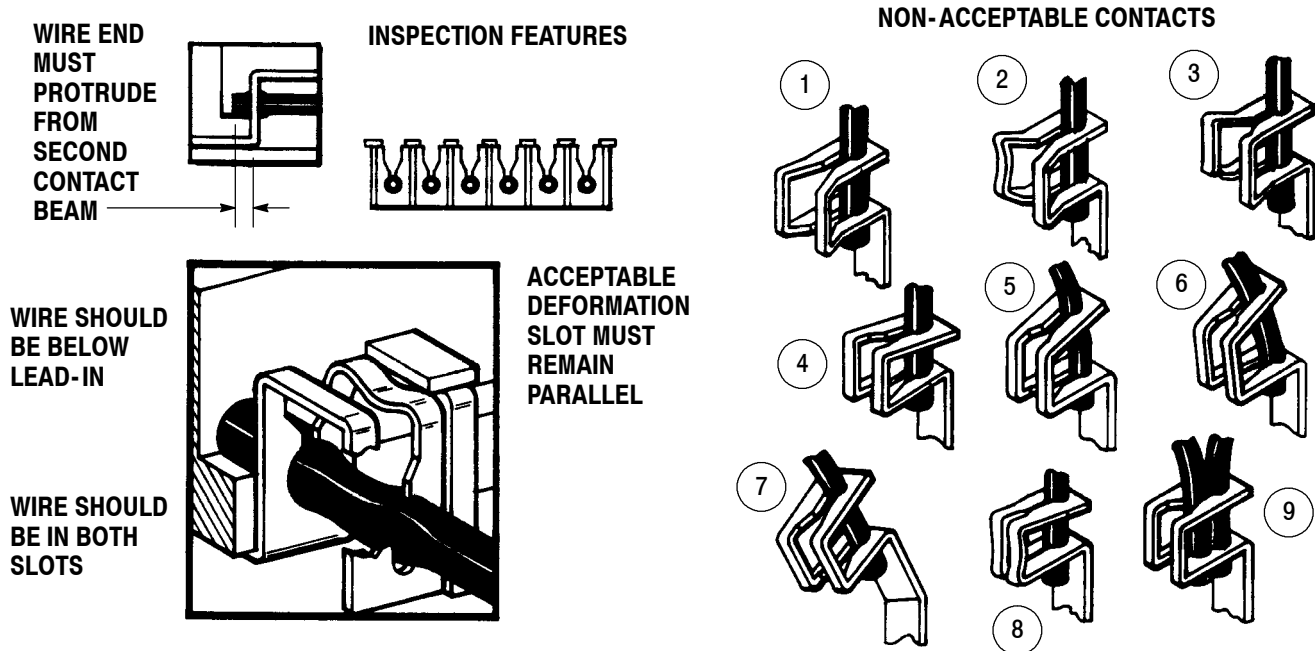

Figure 8

## 6. VISUAL AID

Figure 9 shows a typical application of CHAMP Cable Connectors. This illustration should be used by production personnel to ensure a correctly applied product. Applications which DO NOT appear correct should be inspected using the information in the preceding pages of this specification and in the instructional material shipped with the product or tooling.



The following conditions constitute non-acceptable terminations, and the contact should be removed and replaced.

1. Shoulders are bent and not parallel.
2. Shoulders are bent, bowed, and not parallel.
3. Contact is broken.
4. Strain relief slot is bent inward.
5. Strain relief slot is bent outward.
6. Strain relief slot is bent outward and contact slot is bent inward.
7. Contact is loose and bent.
8. Contact is crushed.
9. Two wires are in the same slot.

**NOTE:** This condition is non-acceptable only if the slot is not specifically designed for a two-wire application.

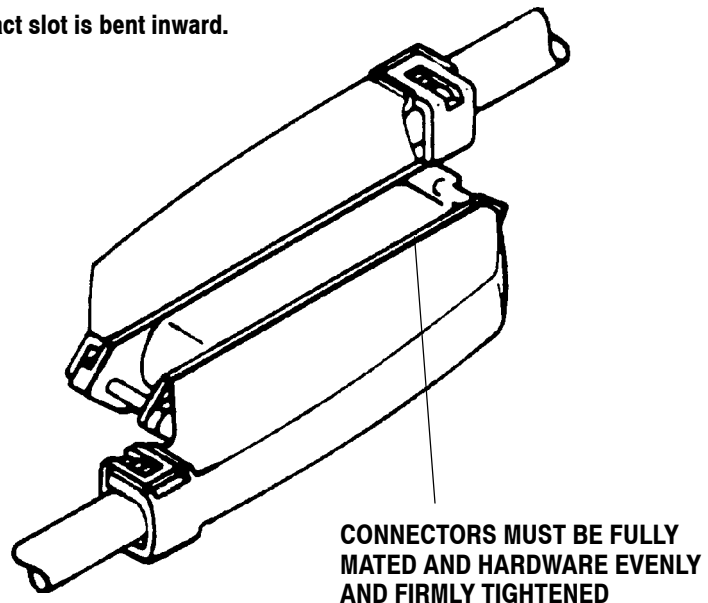

FIGURE 9. VISUAL AID