



Chipsmall Limited consists of a professional team with an average of over 10 year of expertise in the distribution of electronic components. Based in Hongkong, we have already established firm and mutual-benefit business relationships with customers from,Europe,America and south Asia,supplying obsolete and hard-to-find components to meet their specific needs.

With the principle of “Quality Parts,Customers Priority,Honest Operation,and Considerate Service”,our business mainly focus on the distribution of electronic components. Line cards we deal with include Microchip,ALPS,ROHM,Xilinx,Pulse,ON,Everlight and Freescale. Main products comprise IC,Modules,Potentiometer,IC Socket,Relay,Connector.Our parts cover such applications as commercial,industrial, and automotives areas.

We are looking forward to setting up business relationship with you and hope to provide you with the best service and solution. Let us make a better world for our industry!



Contact us

Tel: +86-755-8981 8866 Fax: +86-755-8427 6832

Email & Skype: info@chipsmall.com Web: www.chipsmall.com

Address: A1208, Overseas Decoration Building, #122 Zhenhua RD., Futian, Shenzhen, China



- ① HOUSING MATERIAL: GLASS-FILLED POLYMER.
- ② CONTACT MATERIAL: COPPER ALLOY.
- ③ CONTACT FINISH: DIN 41612 CLASS 2 IN CONTACT AREA. TIN PLATE ON POSTS.
- ④ RECOMMENDED HOLE SIZE FOR MANUAL APPLICATION OF CONNECTOR ONTO PC BOARD.
- ⑤ PART NUMBER, DATE CODE IDENTIFICATION, CSA LOGO IN THIS APPROXIMATE AREA, ON REVERSE SIDE.
- ⑥ CONTACT POINT.

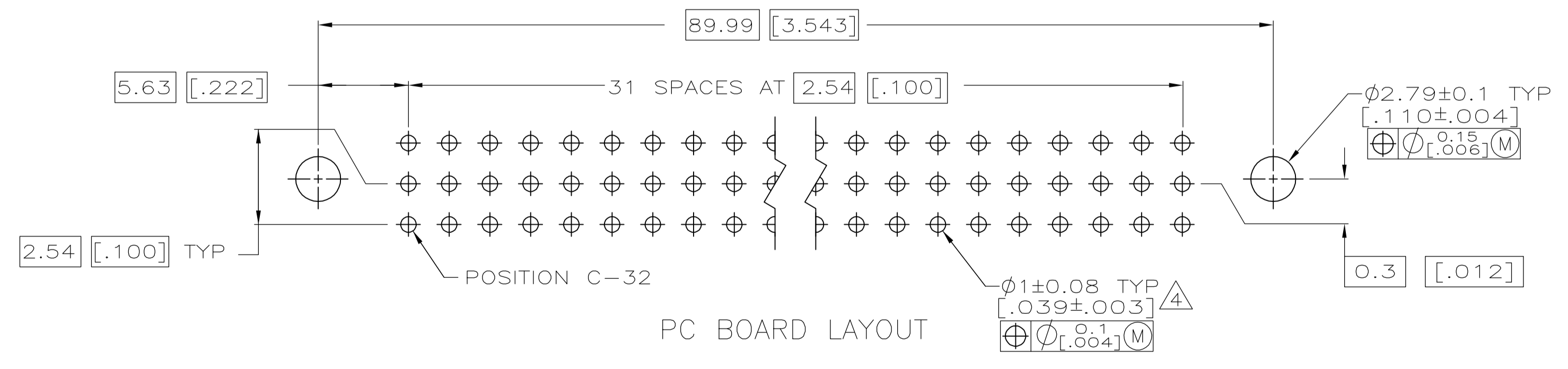
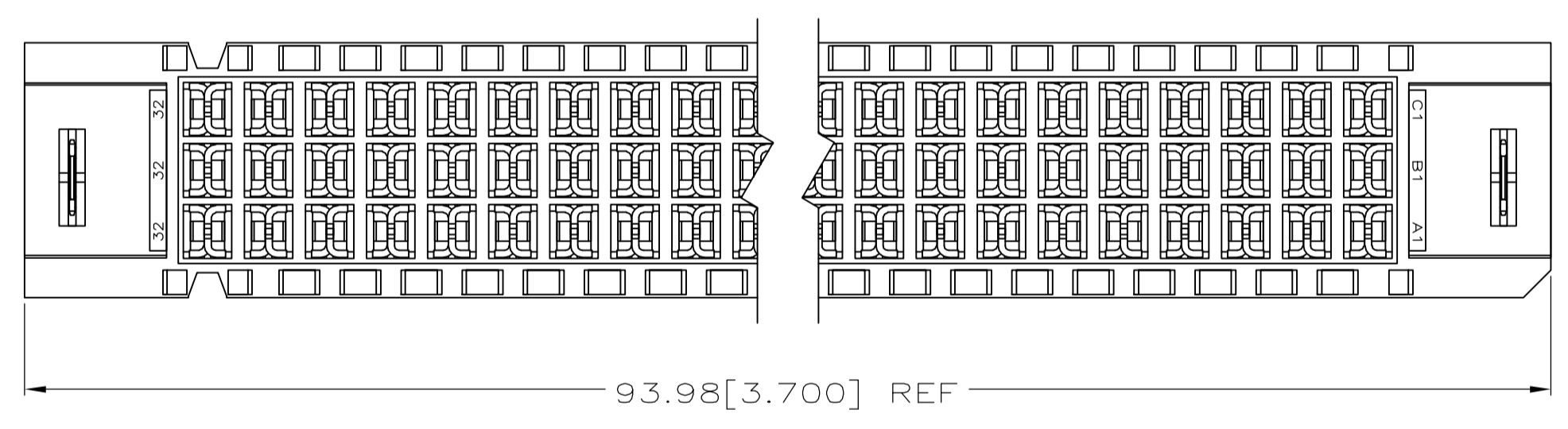
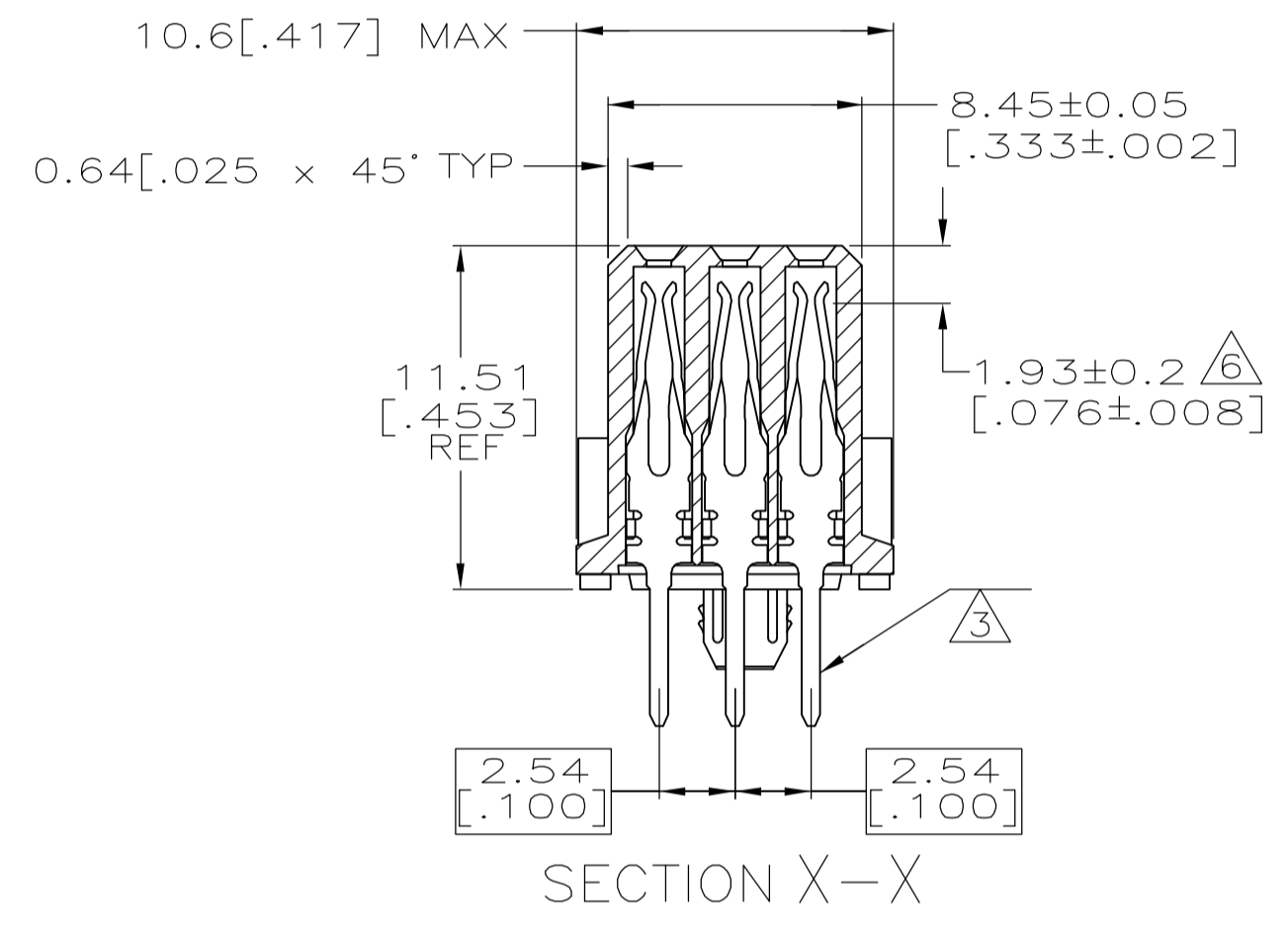
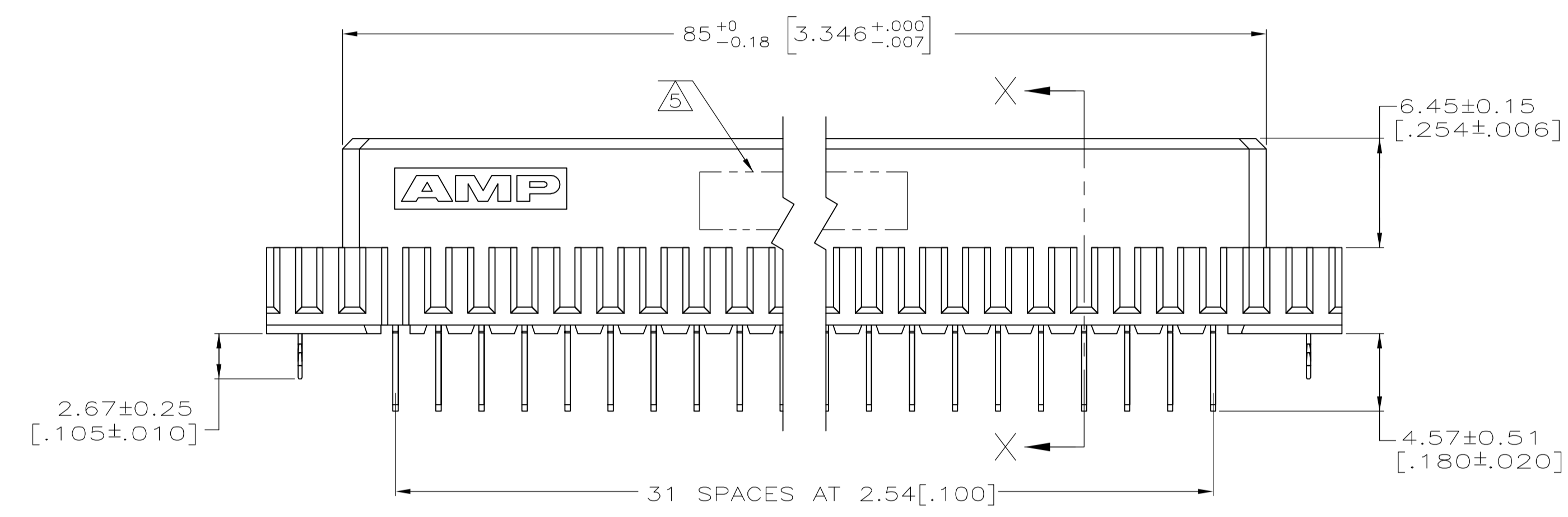
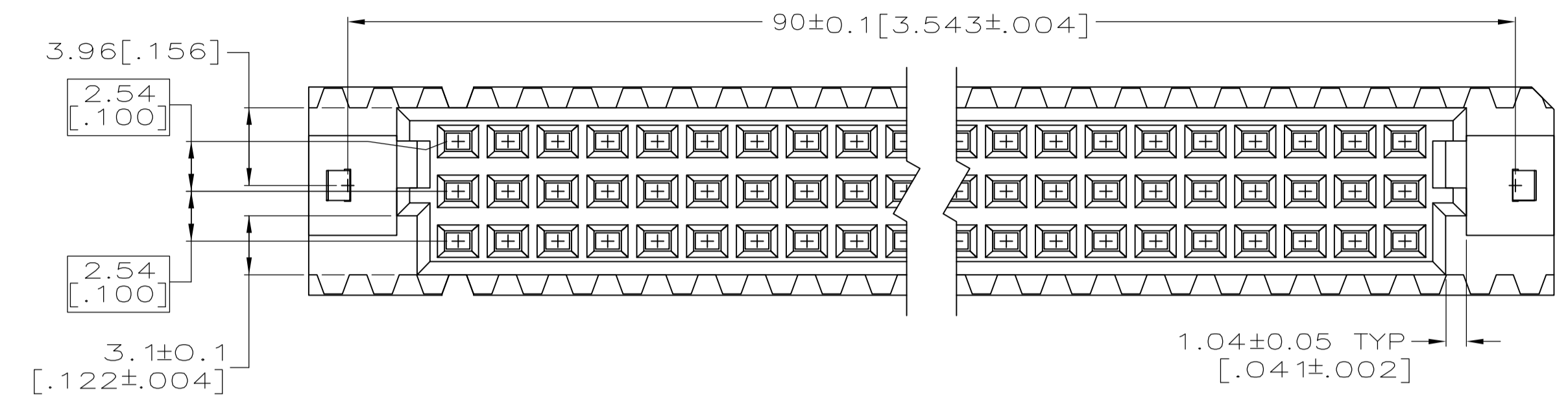

1-32	C	32	5536412-4
1-32	B	32	
1-32	A	32	
POSITIONS LOADED	ROWS	NO. OF LOADED POSITION	ASSY PART NUMBER

THIS DRAWING IS A CONTROLLED DOCUMENT.

DIMENSIONS: mm [INCHES]	TOLERANCES UNLESS OTHERWISE SPECIFIED:	0 PLC ± -	1 PLC ± -	2 PLC ± 0.13[.005]	3 PLC ± -	4 PLC ± -	ANGLES ± -
MATERIAL		FINISH		WEIGHT		SIZE	
①/②		③		A1 00779		C=5536412	

DWG: J. POLIGNONE 27MAY05
 CHK: A. SHARPE 27MAY05
 APVD: A. SHARPE 27MAY05
 NAME: ASSEMBLY, RECEPTACLE, EUROCARD, TYPE C, LEAD-FREE, 96 POSITION, 4.57[.180] SOLDER POSTS WITH BOARD-LOCKS
 Tyco Electronics Corporation, Harrisburg, Pa 17105-3608
 SCALE: 4:1 SHEET 1 OF 1 REV 0